



ALUESTE

P E R F I L E

MUITO MAIS QUE
ALUMÍNIO

Mais de 4000 produtos entre

- ✓ Perfis de alumínio.
- ✓ Componentes e acessórios.
- ✓ Ferramentas e estampos para serralheria.
- ✓ Chapas e acessórios de Policarbonato.
- ✓ Chapas de alumínio e ACM.



NOSSO



NORTE



MISSÃO

Distribuir produtos de qualidade com foco na inovação e oferecer suporte técnico, gerando resultado aos nossos clientes.



VISÃO

Ser reconhecida como a maior empresa do segmento no Brasil



VALORES

- ▶ Respeito ao cliente
- ▶ Compromisso com qualidade
- ▶ Transparência
- ▶ Valorização do ser humano
- ▶ Foco no resultado

UMA ESCOLHA SÓLIDA E INTELIGENTE

A **Alueste Perfil** surgiu para suprir a demanda por atendimento especializado aos profissionais do alumínio e vidro. Desde 1999 no mercado ligado à construção civil, atua na comercialização de uma infinidade de produtos: perfis, chapas e bobinas de alumínio, componentes e ferragens, máquinas e ferramentas, entre outros.



Linha Perfil[®]

D' CASA



APRESENTAMOS NOSSA NOVA LINHA DE PERFIS E COMPONENTES PARA PORTAS:

Linha Perfil[®]



D' CASA

É UMA LINHA PARA PRODUÇÃO DE PORTAS DE ALTO PADRÃO, PARA GIRO, PIVOTANTE OU CORRER.



ENTRE SEUS DIVERSOS BENEFÍCIOS ESTÃO:

FACILIDADE PARA MONTAGEM

USO DE POUCOS TIPOS DE PERFIL

POSSIBILIDADE DE REGULAGEM DO MARCO (VISTA)

MARCO QUE ENVOLVE TODA A ALVENARIA

ALÉM, É CLARO, DE **BELEZA E DESIGN** SEM IGUAL!

PODE SER USADO NAS LINHAS: 25, SUPRA, 30, GOLD E 42.

APF-059

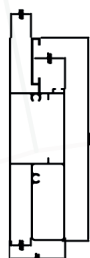

APF-060

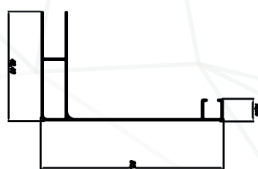

APF-989



APF-988

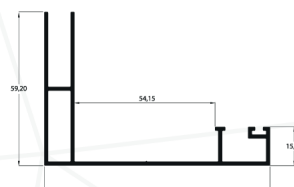



TECNOPERFILE

Na **Aluste Perfile**, você conta com um departamento exclusivo com especialistas em fabricação de esquadrias de alumínio que estão a disposição para a interpretação de projetos e orçamentos.

A experiência que você pode confiar.

asa
alumínio

Aprovado

**Resistência
Estrutural**

Isolamento

Estanquidade

Vedação

NBR 10.821

NBR 15.575



Mega[®] 25
**Sistemas Construtivos
em Alumínio 32**

O sistema MEGA é composto por linhas que atendem todos os níveis de exigência. Conseqüentemente, são três bitlas distintas, com a propriedade de se comunicarem entre si, permitindo assim, obter-se a mais ampla gama de tipologias.



Acompanha o tradicionalismo e consagrado padrão 25mm para atender fechamentos de vãos dos mais diferentes níveis de exigência da arquitetura brasileira.



Desenvolvida para um nível de sofisticação mais elevado. Os perfis mais robustos apresentam-se como soluções adequadas para fechamentos de grandes vãos.

ÍNDICE

PERFIS

Perfis tabelados.....	8
Contramarco, cantoneira e cunha	12
Arremates.....	14
Linha Mega 25.....	15
Linha Perfil - Integrada	30
Linha D'casa.....	36
Linha 25	40
Linha Supra - Porta de Giro	42
Linha Módulo Especial.....	44
Linha 30	46
Linha 42	49
Venezianas	51
Lambris e Brises	54
Perfis para Portões	57
Linha Supra	60
Linha Dior	77
Linha PVII.....	94
Fechamento de Sacada	102
Linha Atlanta	103
Policarbonato.....	112
Vidro Temperado 8mm	113
Vidro Temperado 10mm	115
Box Vidro Temperado.....	118
Vidro Temperado	119
Gradil e Corrimão	121
Box Acrílico	124
Fachada Cortina	125

COMPONENTES PARA ESQUADRIAS

Guias, drenos e fixadores.....	127
Roldanas	129
Fechos e Contra Fechos	131
Fechaduras e Contra Fechaduras	133
Tampas.....	135
Maxim-ar e Basculante	136
Integradas.....	138
Motores	140
Dobradiças	141
Linha Camarão	142
Borrachas, Guarnições e Fitas.....	143
PVII e Atlanta.....	145
Ferragens para Vidro Temperado	150
Puxadores	159
Acessórios Diversos	160
Parafusos.....	162
Chapas e Bobinas.....	163



TUBOS QUADRADOS

CÓDIGO	MEDIDA	PESO (Kg/mt)
TG025	25,40 x 25,40 - 1,00mm	0,265
TQ025	25,40 x 25,40 - 1,58mm	0,389
TG038	38,10 x 38,10 - 1,00mm	0,402
TQ050	50,80 x 50,80 - 1,58mm	0,802
TQ080	80,00 x 80,00 - 1,80mm	1,525
TQ101	101,60 x 101,60 - 2,50mm	2,686

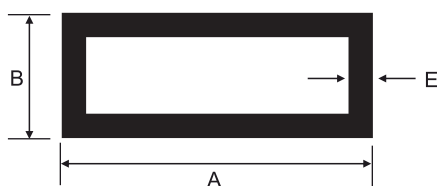

TUBOS RETANGULARES

CÓDIGO	MEDIDA	PESO (Kg/mt)
TG063	25,40 x 12,70 - 1,00mm	0,193
APR012	25,40 x 12,70 - 1,58mm	0,176
TG050	50,80 x 12,70 - 0,90mm	0,290
TG006	50,80 x 25,40 - 1,00mm	0,402
APR025	50,80 x 25,40 - 1,58mm	0,286
APR076	76,20 x 38,10 - 1,58mm	0,850
APR095	95,00 x 50,80 - 1,58mm	1,199
APR101	101,60 x 50,80 - 1,58mm	1,214
APR150	150,00 x 50,80 - 2,00mm	2,332
APR151	152,40 x 50,80 - 1,50mm	1,628

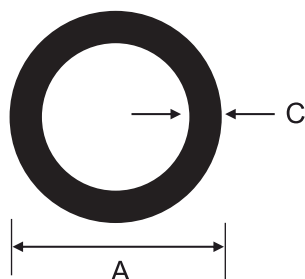

TUBOS REDONDOS

CÓDIGO	MEDIDA	PESO (Kg/mt)
TR009	09,52 x 1,50mm	0,106
TR012	12,70 x 1,58mm	0,150
TR014	15,87 x 1,00mm	0,126
TR015	15,87 x 1,58mm	0,187
TR018	19,05 x 1,00mm	0,154
TR019	19,05 x 1,58mm	0,235
TR024	25,40 x 1,00mm	0,207
TR025	25,40 x 1,58mm	0,320
TR031	31,75 x 1,58mm	0,406
TR038	38,10 x 1,58mm	0,491
TR050	50,80 x 1,58mm	0,662

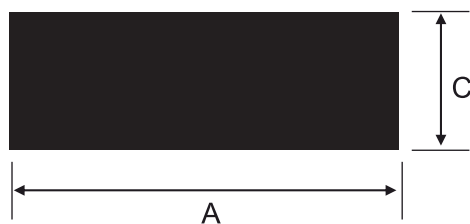
BARRAS CHATAS

CÓDIGO	MEDIDA	PESO (Kg/mt)
BC001	09,52 x 3,17mm	0,492
BC012	12,70 x 3,17mm	0,109
BC015	15,87 x 2,10mm	0,090
BC005	15,87 x 3,17mm	0,137
BC009	15,87 x 4,76mm	0,205
BC002	19,05 x 3,17mm	0,164
BC006	19,05 x 4,76mm	0,246
BC010	22,22 x 3,18mm	0,191
BC007	25,54 x 3,17mm	0,219
BC025	25,40 x 6,35mm	0,435
BC033	31,75 x 3,17mm	0,273
BC038	38,10 x 3,17mm	0,328
BC004	38,10 x 4,76mm	0,490
BC045	50,40 x 3,00mm	0,413
BC062	50,80 x 3,17mm	0,436

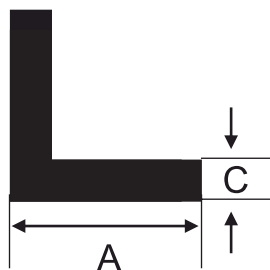

CANTONEIRAS

CÓDIGO	MEDIDA	PESO (Kg/mt)
CT012	12,70 x 1,58MM	0,097
CT015	15,87 x 1,58MM	0,115
CT019	19,05 x 1,58MM	0,149
CT025	25,40 x 1,58MM	0,200
CT026	25,40 x 3,17MM	0,409
CT038	38,10 x 3,17MM	0,627
CT050	50,80 x 1,58MM	0,428
CT051	50,80 x 3,17MM	0,845

CL006 CONEXÃO CANTONEIRA
49MM - 3 MT
0,980 kg/m

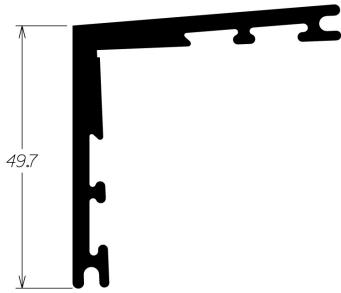

CL011 CONEXÃO CUNHA 50 x
1,50MM - 3 MT
0,313 kg/m

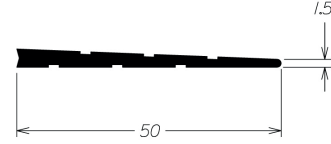

CL044 CONEXÃO CANTONEIRA
64MM - 3 MT
1,086 kg/m

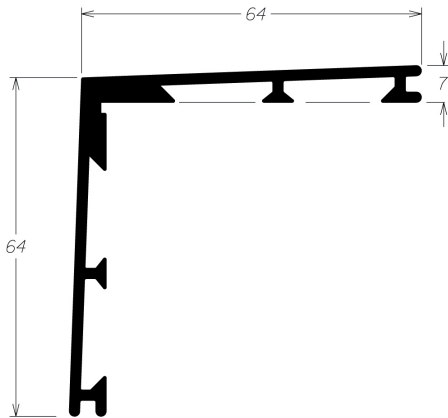

CL010 CONEXÃO CUNHA 60 x
1,40MM - 3 MT
0,371 kg/m

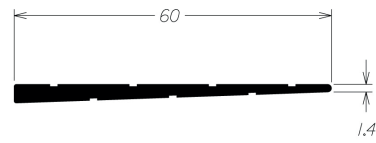

CL007 CONEXÃO CANTONEIRA
54MM - 3 MT
0,938 kg/m

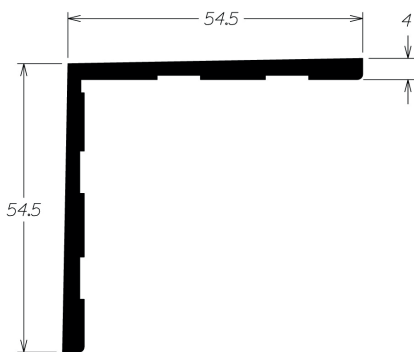

CL046 CONEXÃO CUNHA 45 x
1,50MM - 3 MT
0,233 kg/m

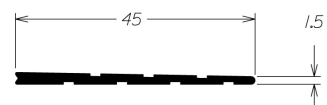

CM060

CONTRAMARCO

0,260 kg/m

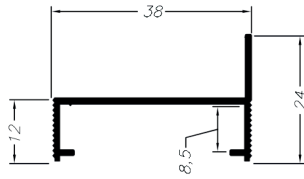

CM200

CONTRAMARCO DE
JANELA

0,164 kg/m

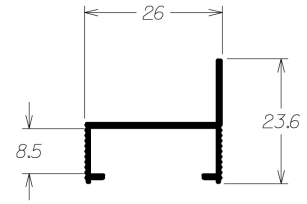

CM063

CONTRAMARCO DE
JANELA REFORÇADO

0,200 kg/m

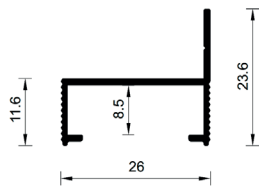

CM151

CONTRAMARCO DE
PORTA

0,210 kg/m

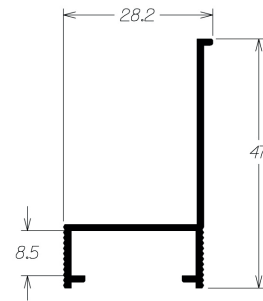

CM098

CONTRAMARCO PARA
PORTA

0,281 kg/m

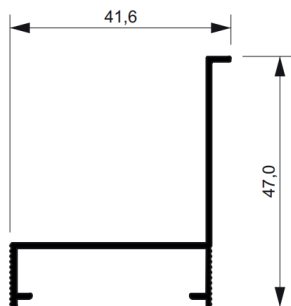

CM032

CONTRAMARCO

0,513 kg/m

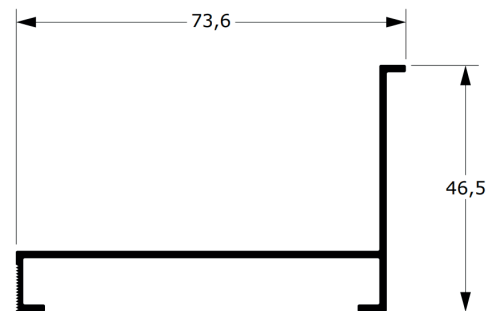

CHU850

CHUMBADOR

0,626 kg/m

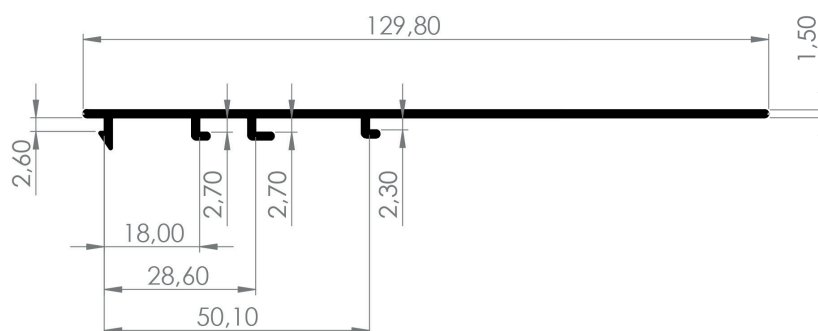

ME013

ARREMATE DE PISO

0,236 kg/m

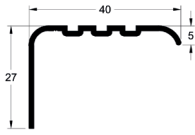

CM130

ARREMATE INTERNO

0,163 kg/m

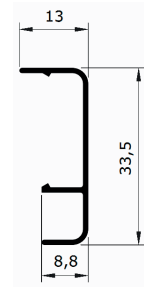

MP347

ARREMATE INTERNO

0,164 kg/m

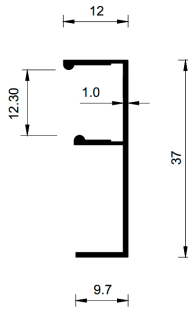

RA1009

ARREMATE INTERNO

0,209 kg/m

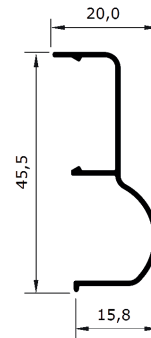

CM008

PERFIL T

0,170 kg/m

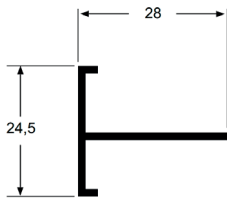

RA1175

ARREMATE INTERNO

0,297 kg/m

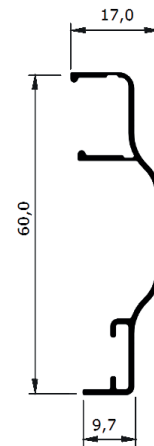

ITEM SOB CONSULTA

CM169

ARREMATE DE PISO

0,402 kg/m

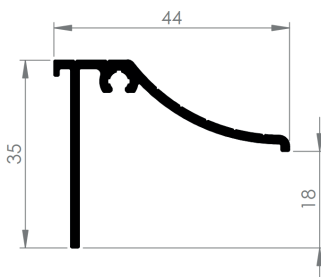

CM075

ARREMATE DE PORTA

0,288 kg/m

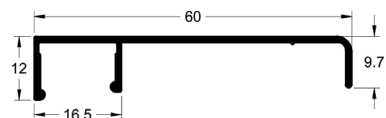

MG25508

MARCO SUPERIOR 2
PLANOS

0,810 Kg/m

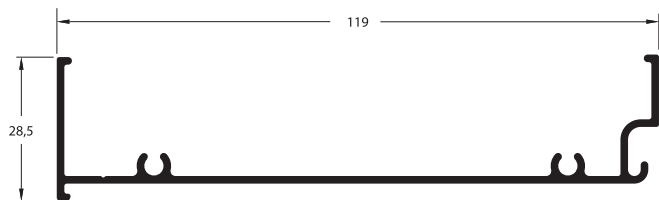

MG25509

TRILHO SUPERIOR 2
PLANOS

0,843 Kg/m

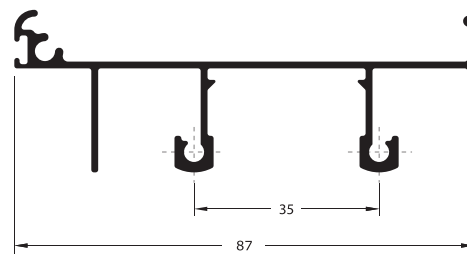

MG25510

TRILHO INFERIOR 2
PLANOS

1,085 Kg/m

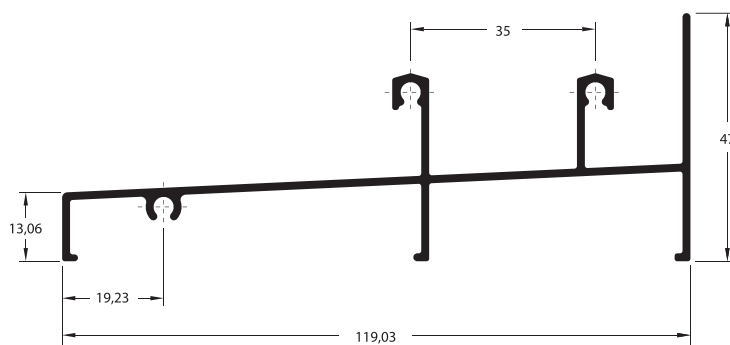

APG25510

TRILHO INFERIOR 2
PLANOS

0,578 Kg/m

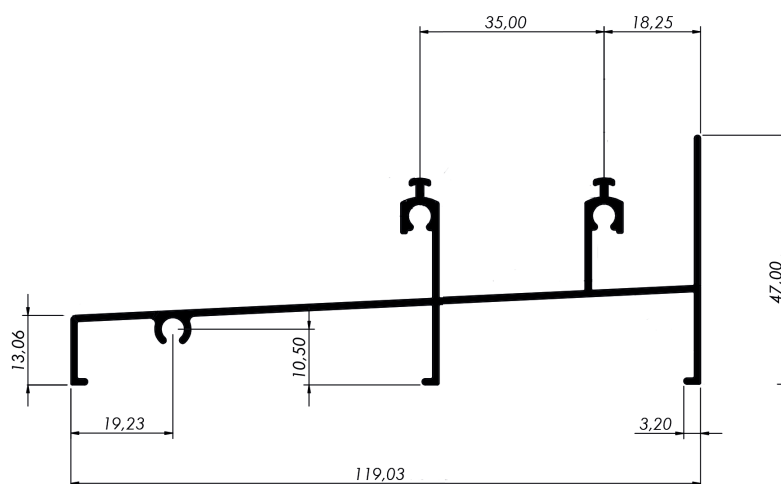

MGT-2586



MG25513

GUIA DO RECOLHEDOR
2 PLANOS

1,075 Kg/m

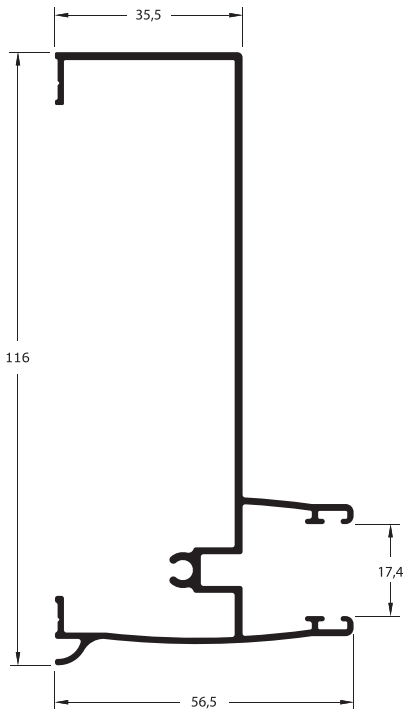

MG25511

MARCO LATERAL 2
PLANOS

0,578 Kg/m

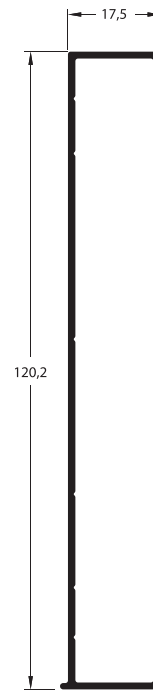

MG25514

GUIA DA PERSIANA 2
PLANOS

0,741 Kg/m

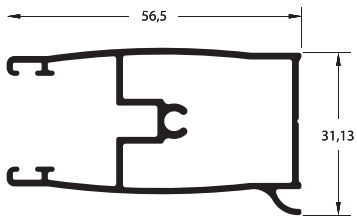

MG25516

TAMPA EXTERNA JANELA

0,724 Kg/m

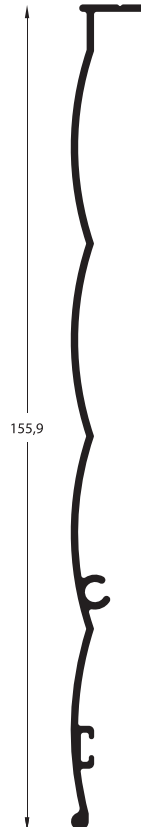

MG25515

TAMPA INTERNA JANELA

0,857 Kg/m

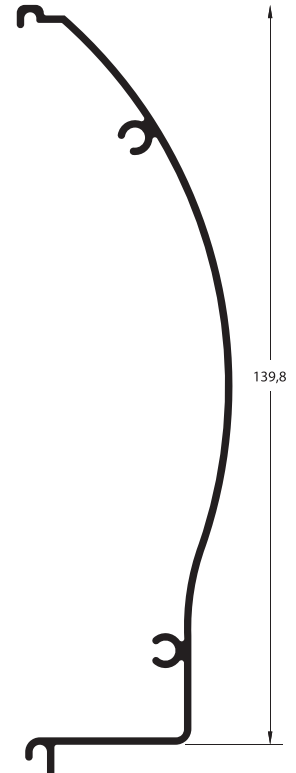

MN027

COLUNA CENTRAL

0,977 Kg/m

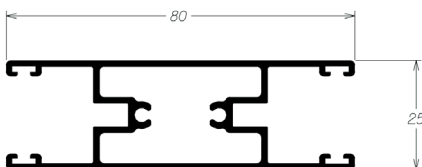

MG32109

TAMPA EXTERNA PORTA

0,922 Kg/m

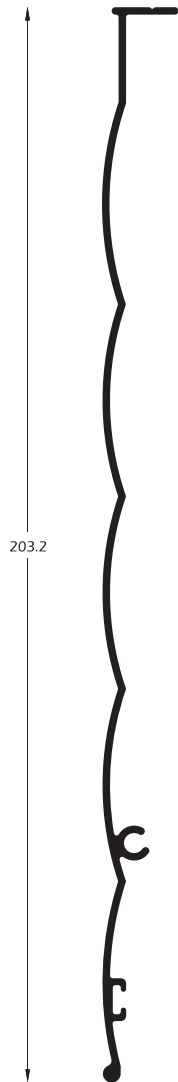

MG32110

TAMPA INTERNA PORTA

1,274 Kg/m

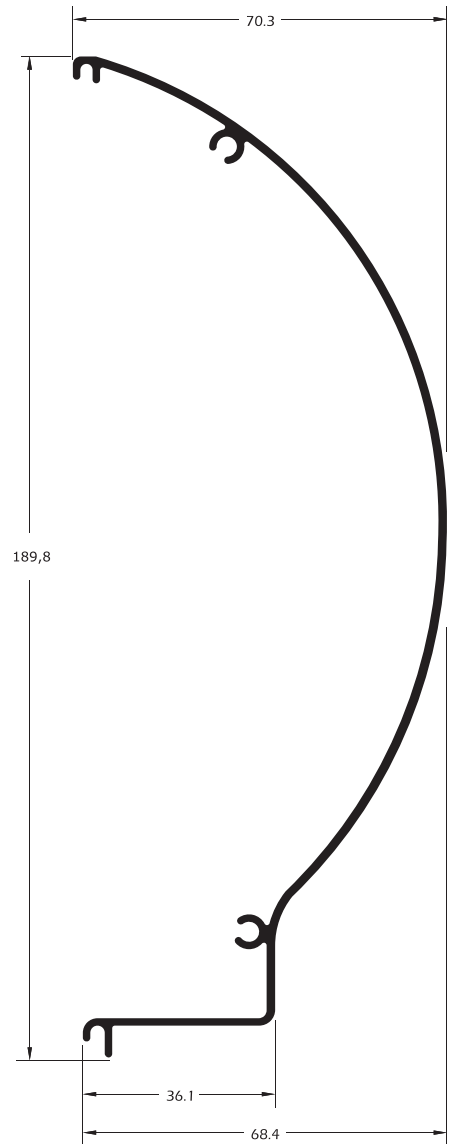

MG25518
1,062 Kg/m
TAMPA INTERNA

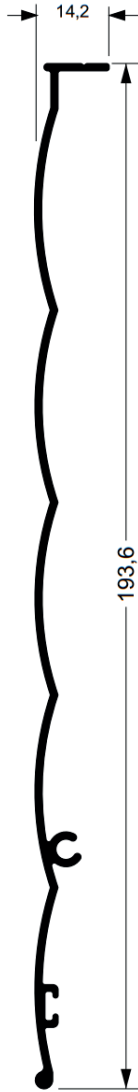

MG25517
0,885 Kg/m
TAMPA EXTERNA

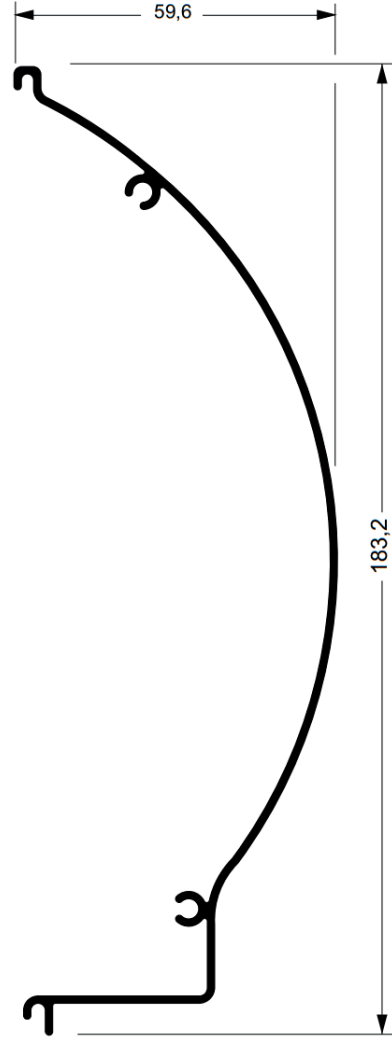

MG25334
1,000 Kg/m
MARCO SUPERIOR 3 PLANOS

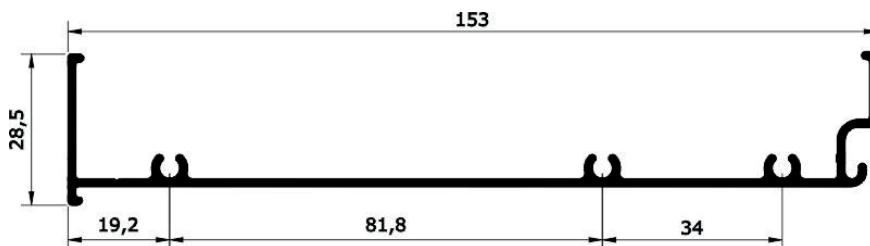

MG25335

TRILHO INTERMEDIARIO 3
PLANOS

1,223 Kg/m

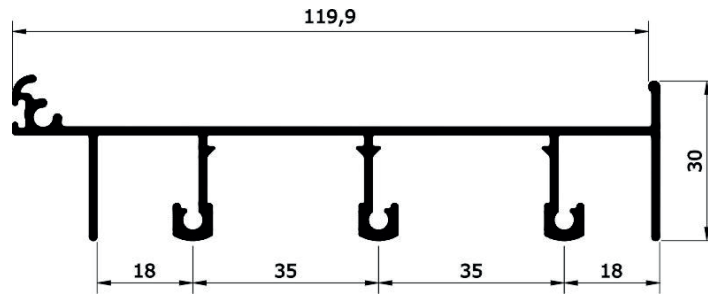

MG25333

TRILHO INFERIOR 3
PLANOS

1,349 Kg/m

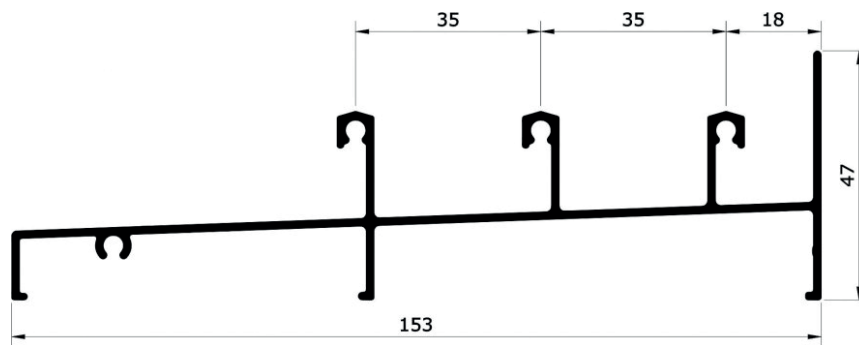

MG25336

MARCO LATERAL
INTEGRADA 3 PLANOS

0,782 Kg/m

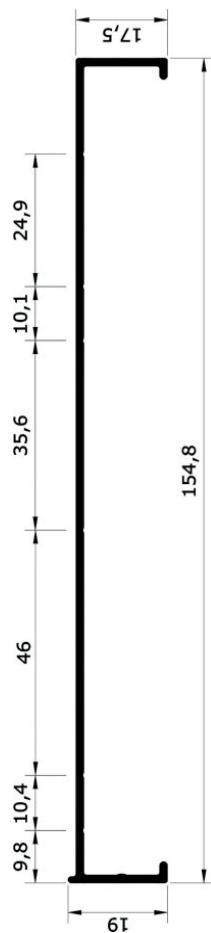

MG25337

GUIA DO RECOLHEDOR 3
PLANOS

1,294 Kg/m

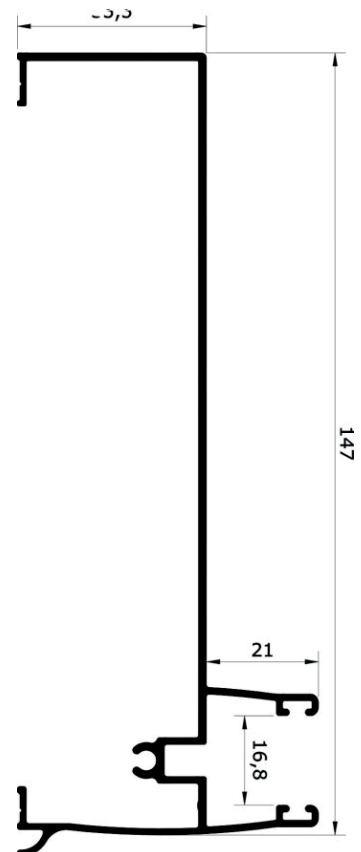

MG32062

TERMINAL DA PERSIANA

0,270 Kg/m

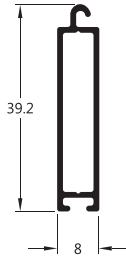

MG32046

TERMINAL DA PERSIANA

0,312 Kg/m

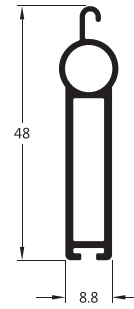

MG32063

EIXO INTEGRADA 40MM

0,441 kg/m

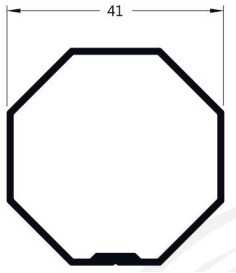

MG32032

EIXO INTEGRADA 60MM

0,881 kg/m

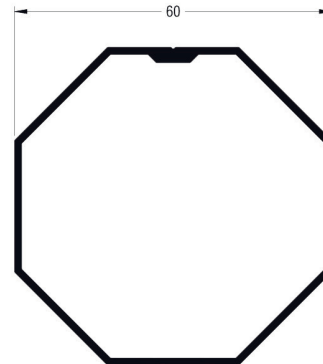

MG25001

TRILHO SUPERIOR 2 PLANOS

0,773 Kg/m

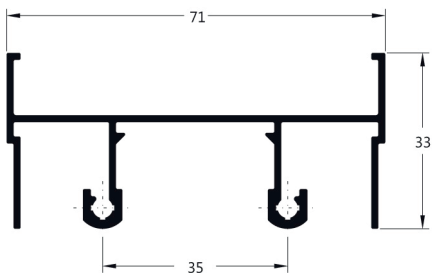

MG25002

TRILHO INFERIOR JANELA 2 PLANOS

0,711 Kg/m

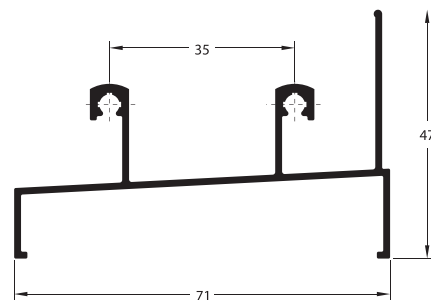

MG25007

MARCO LATERAL 2
PLANOS

0,386 Kg/m

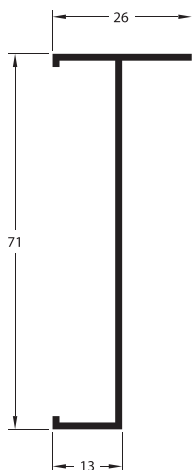

MG25003

MARCO LATERAL 2
PLANOS

0,537 Kg/m



MG25004

MARCO BANDEIRA DE
PEITORIL

0,526 Kg/m

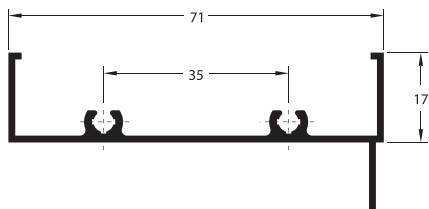

MG25791

MARCO LATERAL 2
PLANOS

0,561 Kg/m

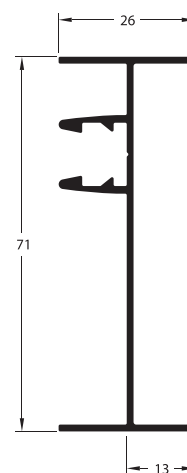

MG25006

TRAVESSA PEITORIL FIXO

0,845 Kg/m

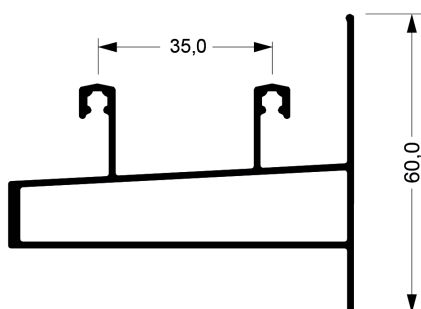

MG25009

TRAVESSA QUADRO FIXO
MAXIM-AR

0,864 Kg/m

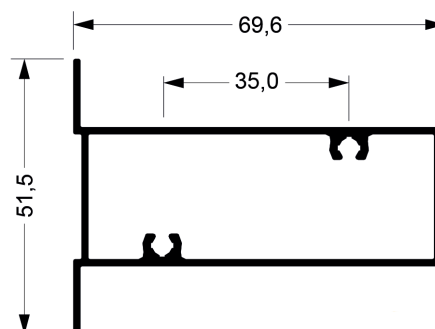

MG25005

TRAVESSA BANDEIRA FIXA

1,103 Kg/m

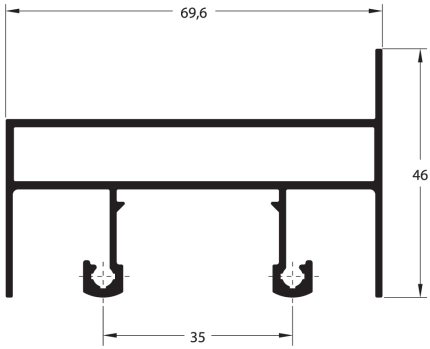

MG25010

TRILHO SUPERIOR 3 PLANOS

1,028 Kg/m

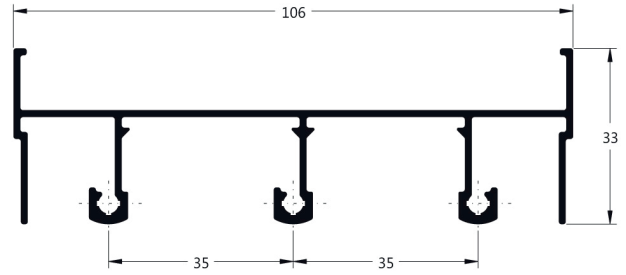

MG25011

TRILHO INFERIOR JANELA 3 PLANOS

0,960 Kg/m

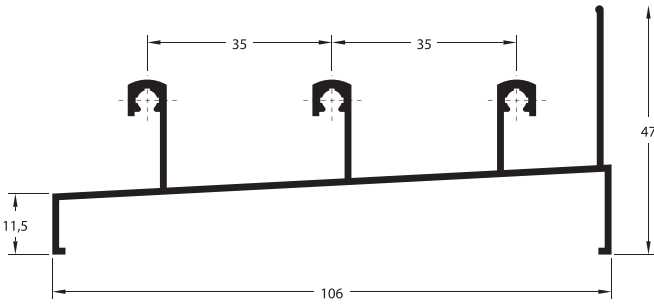

MG25228

TRILHO INFERIOR PORTA 2 PLANOS

0,791 Kg/m

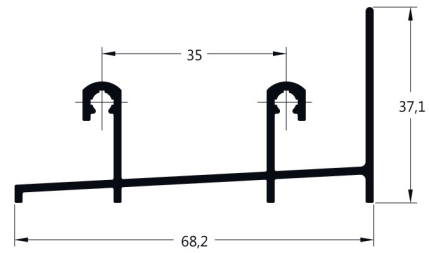

MG25230

TRILHO INFERIOR PORTA 3 PLANOS

0,976 Kg/m

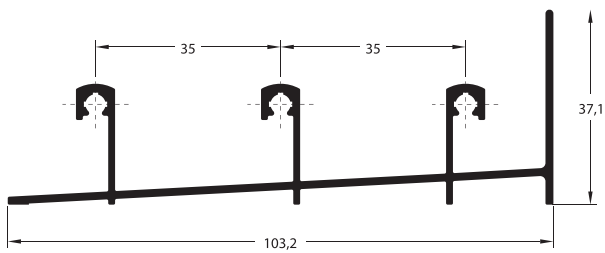

MG25012

MARCO LATERAL LISO 3 PLANOS

0,559 Kg/m

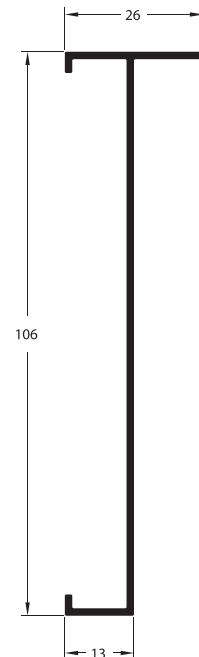

MG25792

MARCO LATERAL 3
PLANOS

0,710 Kg/m

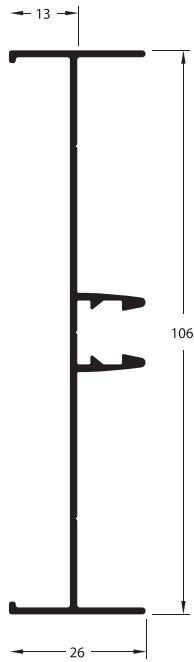

MG25793

MARCO LATERAL 3
PLANOS

0,840 Kg/m

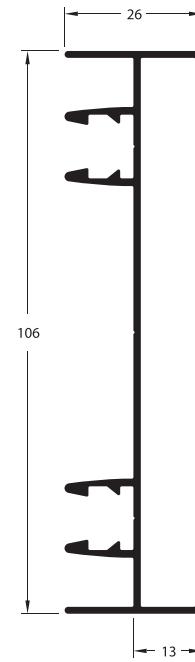

MG25121

TRILHO SUPERIOR 4
PLANOS

1,585 Kg/m

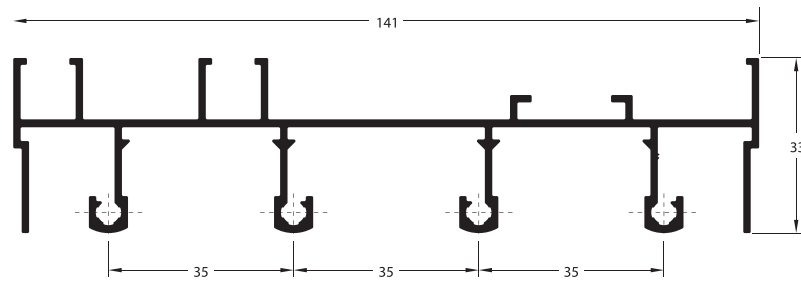

MG25122

TRILHO INFERIOR 4
PLANOS

1,509 Kg/m

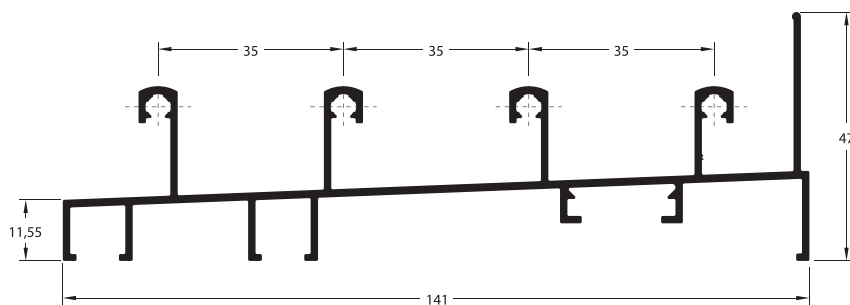

MG25123

MARCO LATERAL LISO 4 PLANOS

0,917 Kg/m

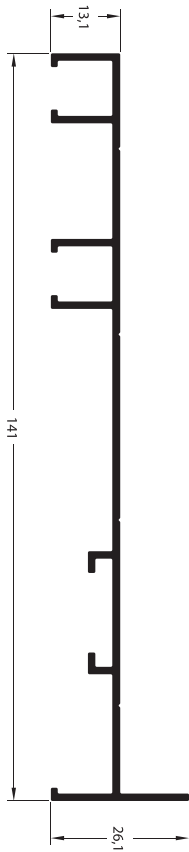

MG25500

MONTANTE DA FOLHA

0,542 Kg/m

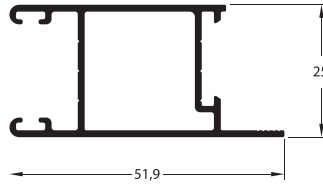

MG25501

MONTANTE CENTRAL DA FOLHA

0,458 Kg/m

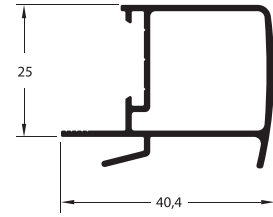

MG25502

MONTANTE CENTRAL COM ENGATE

0,490 Kg/m

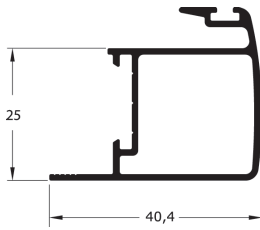

MG25503

MONTANTE CENTRAL INTERMEDIARIO

0,523 Kg/m

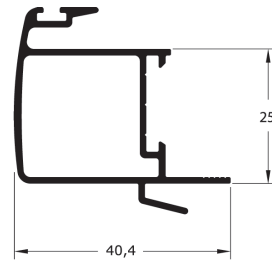

MG25053

TRAVESSA SUPERIOR E INFERIOR

0,542 Kg/m

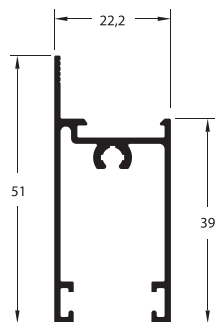

MG25506

MATA JUNTA CENTRAL

0,268 Kg/m

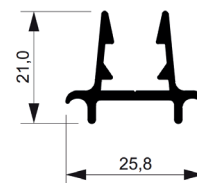

MG25507

MATA JUNTA

0,332 Kg/m

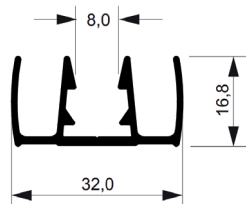

MG25504

MONTANTE BI-TUBULAR
CENTRAL INTERNO

0,757 Kg/m

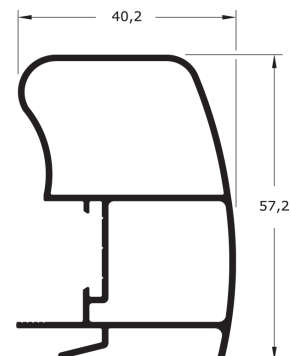

MG25505

MONTANTE BI-TUBULAR
CENTRAL EXTERNO

0,745 Kg/m

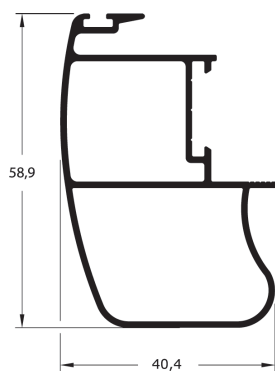

MG25796

MONTANTE BI-TUBULAR
CENTRAL-LATERAL

0,847 Kg/m

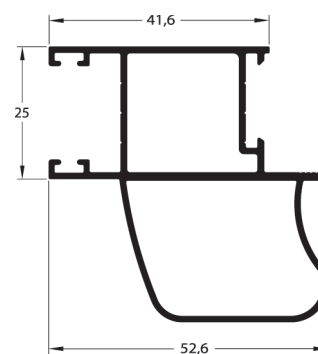

MG25521

MONTANTE BI-TUBULAR
INTERNO

1,036 Kg/m

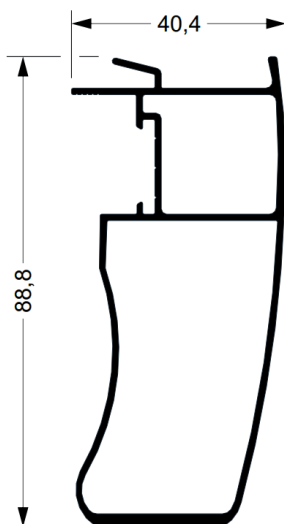

MG25522

MONTANTE BI-TUBULAR
EXTERNO

1,048 Kg/m

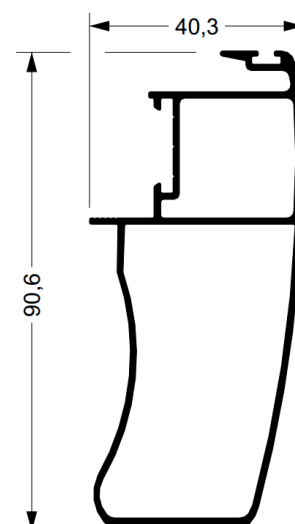

SU280A

MONTANTE DA FOLHA

0,780 Kg/m

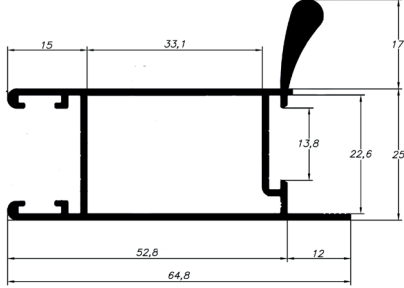

MG25225

TRAVESSA INFERIOR DA FOLHA

0,926 Kg/m

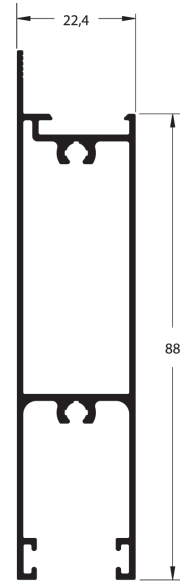

MG25102

BAGUETE MEGA 25

0,110 Kg/m

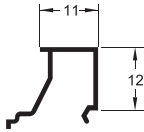

MG25AF18

BAGUETE VERTICAL

0,104 Kg/m

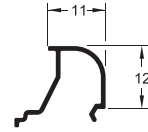

MG25103

BAGUETE MEGA 25

0,156 Kg/m

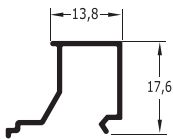

MG25227

TRAVESSA CENTRAL

0,574 Kg/m

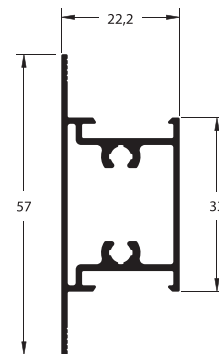

MG25187

TRAVESSA DA FOLHA VENEZIANA

0,534 Kg/m

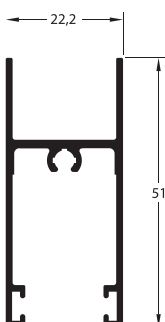

MG25784

MONTANTE DA FOLHA VENEZIANA

0,555 Kg/m

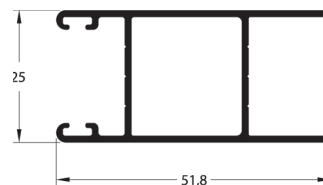

MG25783

MONTANTE INTERMEDIARIO

0,565 Kg/m

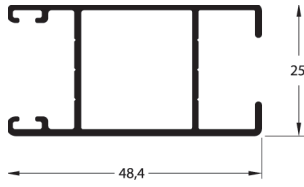

MG25787

MONTANTE MÃO DE AMIGO

0,513 Kg/m

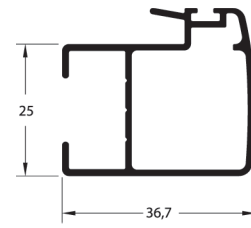

MG25788

MONTANTE INTERMEDIARIO

0,599 Kg/m

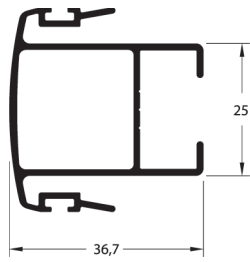

MG25789

MONTANTE TUBULAR CENTRAL

0,774 Kg/m

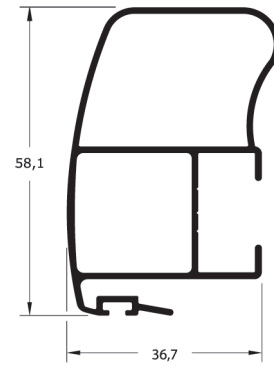

MG25186

TRAVESSA DA FOLHA

0,496 Kg/m

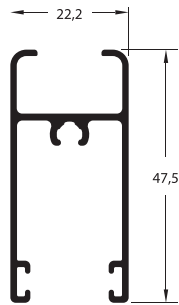

MG25188

TRAVESSA CENTRAL

0,586 Kg/m

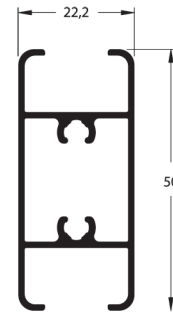

MG25786

MONTANTE INTERMEDIÁRIO VENEZIANA

0,535 Kg/m

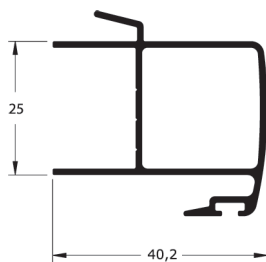

MG25785

MONTANTE CENTRAL VENEZIANA

0,500 Kg/m

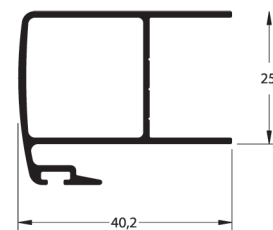

ESQUEMAS DE MONTAGEM

JANELA INTEGRADA 2 FOLHAS

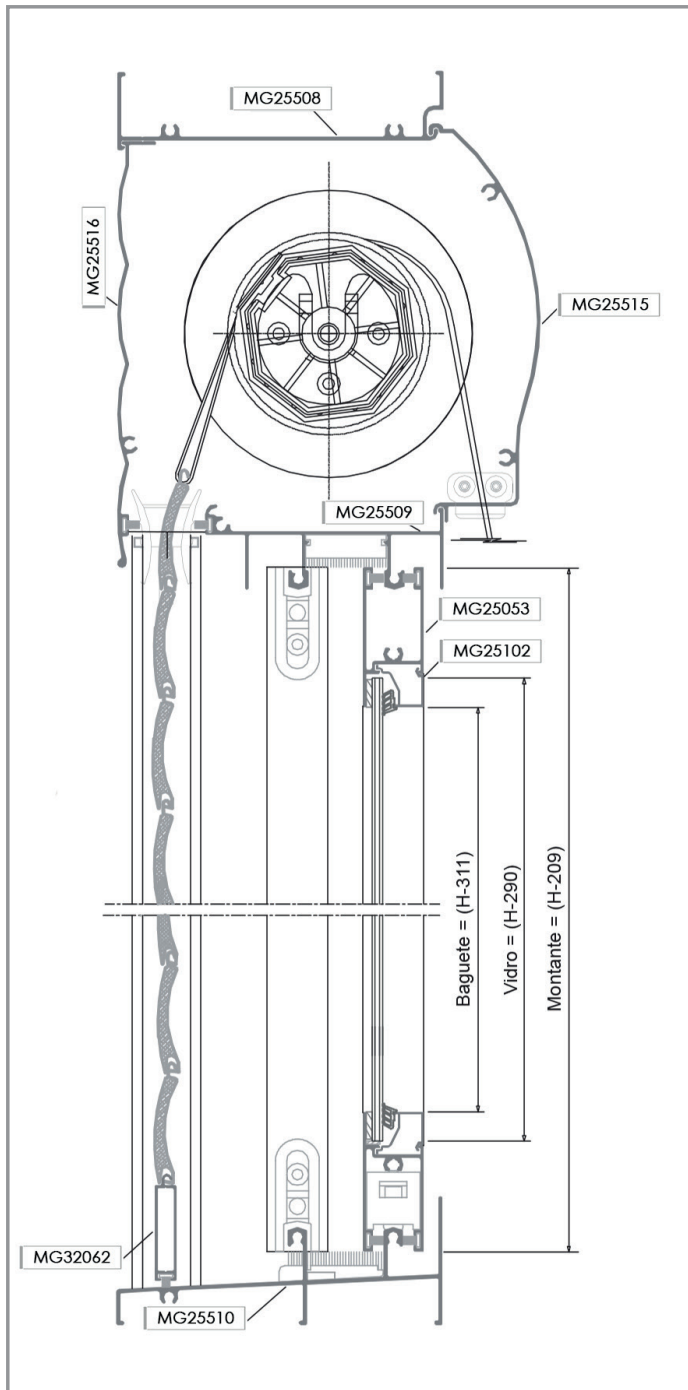

PORTA INTEGRADA 2 FOLHAS

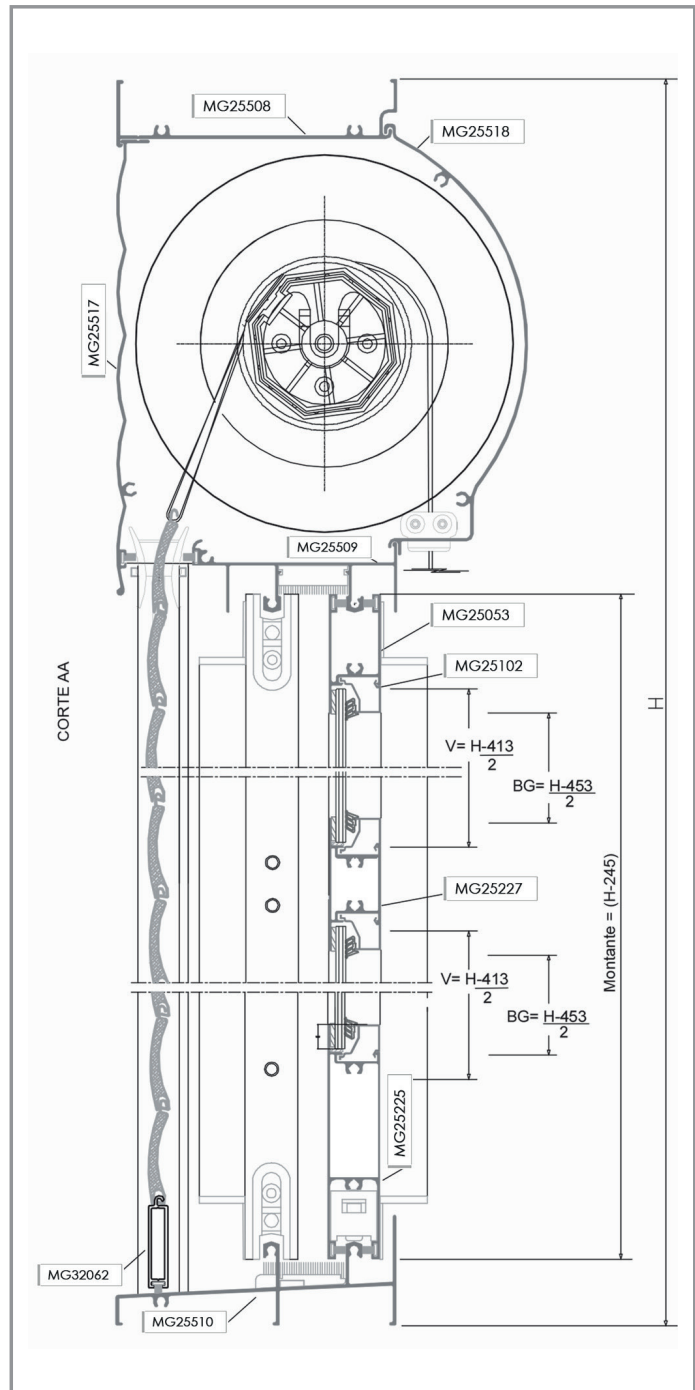

ESQUEMAS DE MONTAGEM

JANELA INTEGRADA 2 FOLHAS

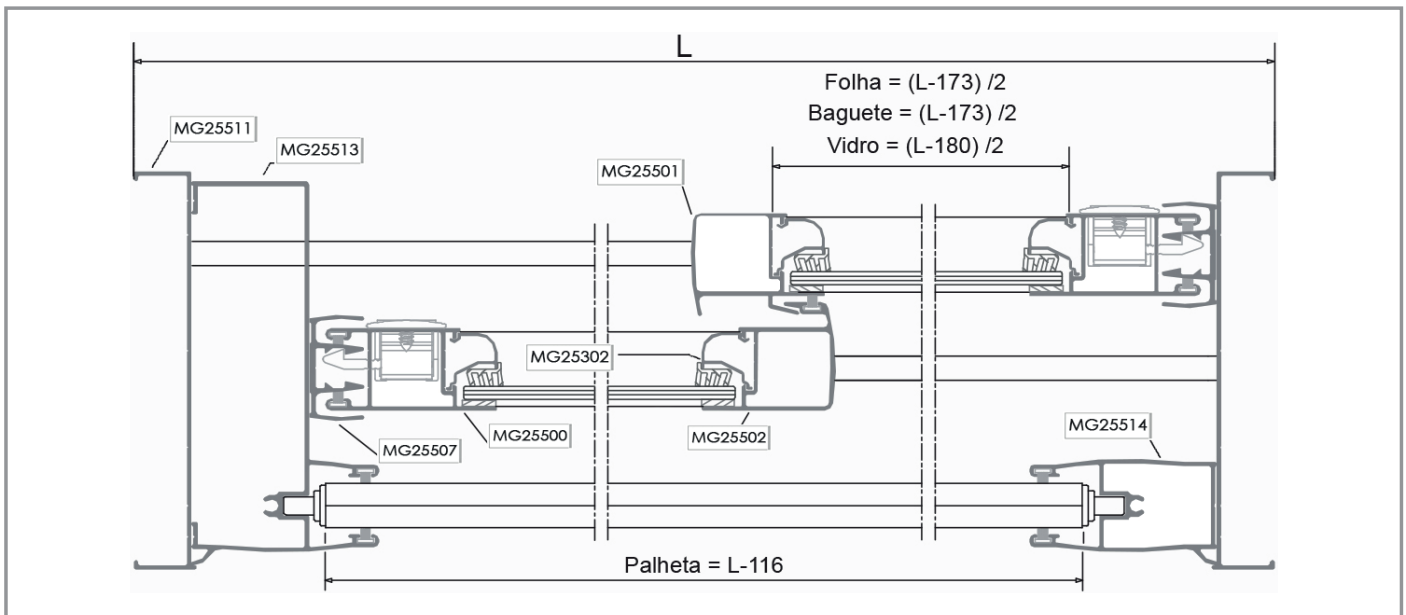

PORTA INTEGRADA 2 FOLHAS

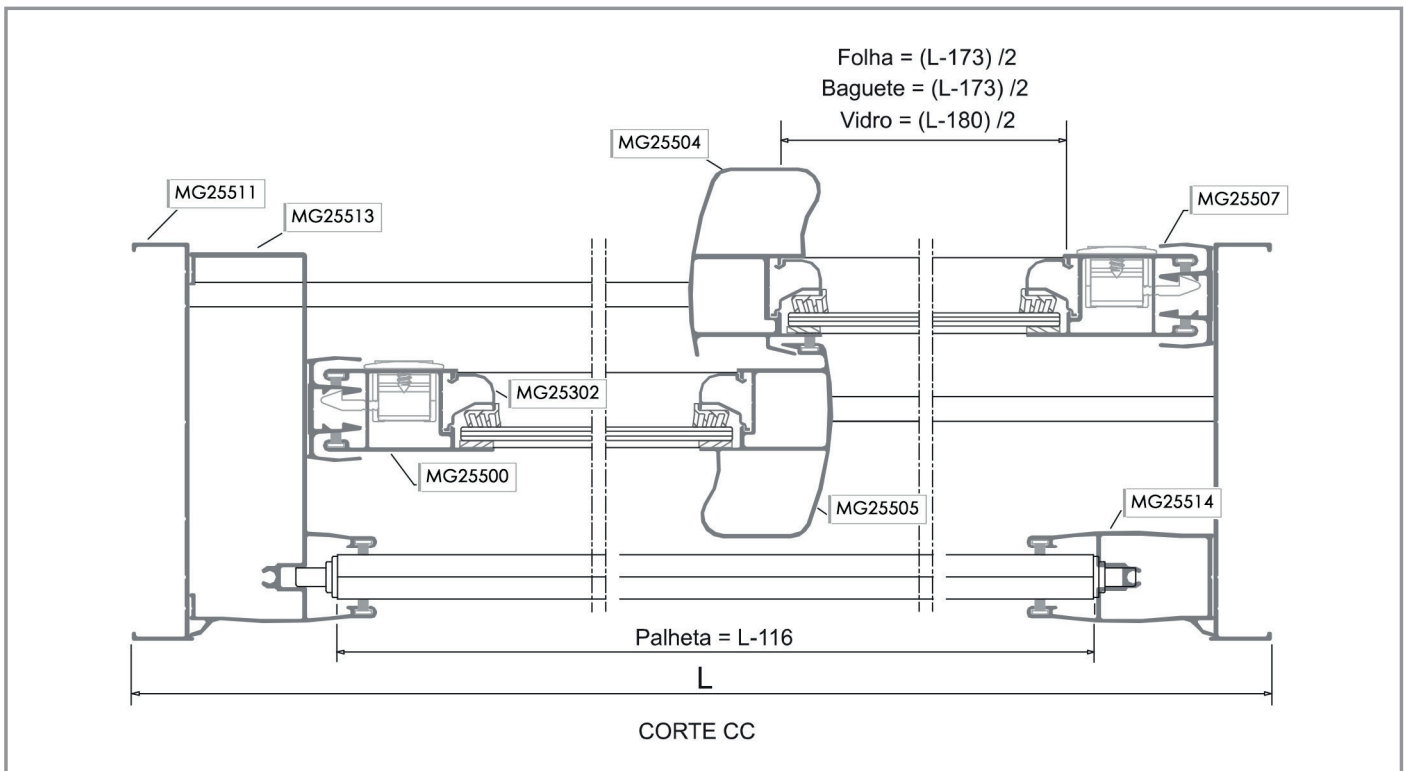

APF001
0,678 Kg/m
MARCO SUPERIOR 2
PLANOS

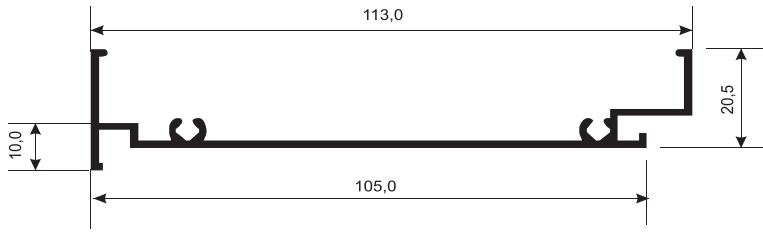

APF002
0,775 Kg/m
TRILHO SUPERIOR 2
PLANOS

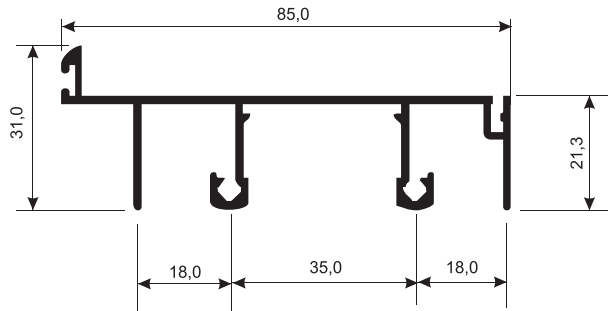

APF003
0,903 Kg/m
TRILHO INFERIOR 2
PLANOS

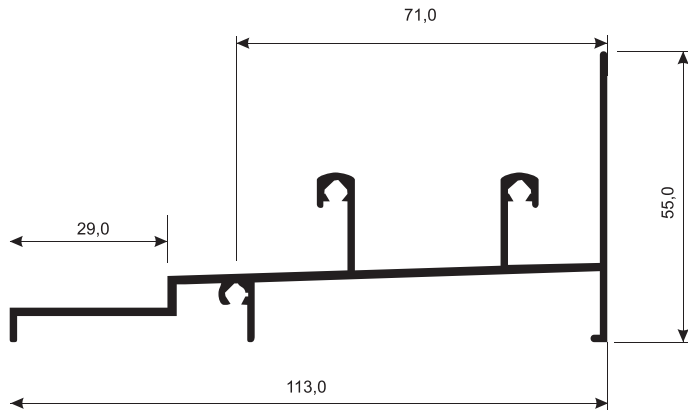

MN010
1,497 Kg/m
TRILHO INFERIOR 2
PLANOS

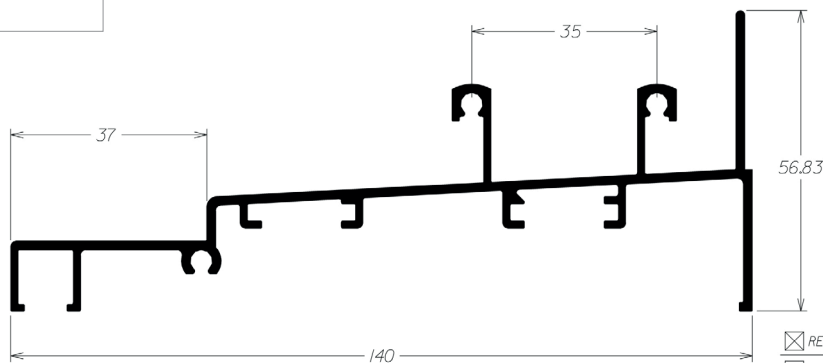

APF178

MARCO SUPERIOR 3
PLANOS
(CAIXA QUADRADA)

1,070 Kg/m

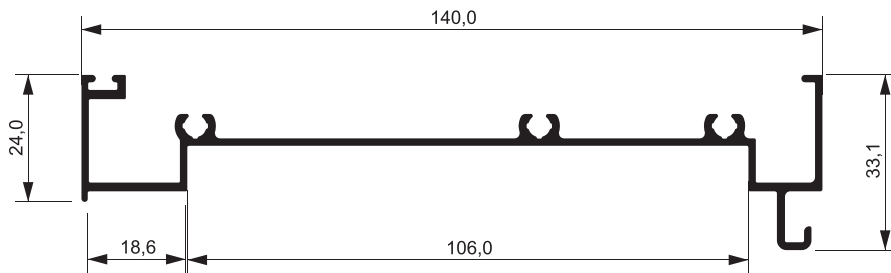

APF100

MARCO SUPERIOR 3
PLANOS

0,840 Kg/m

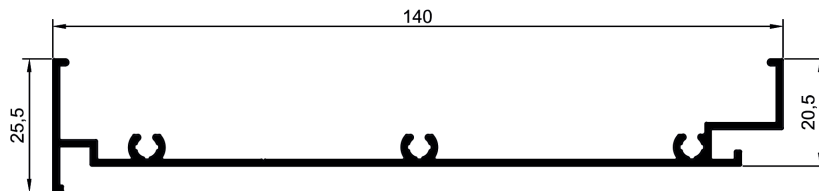

APF176

TRILHO SUPERIOR 3
PLANOS
(CAIXA QUADRADA)

1,518 Kg/m

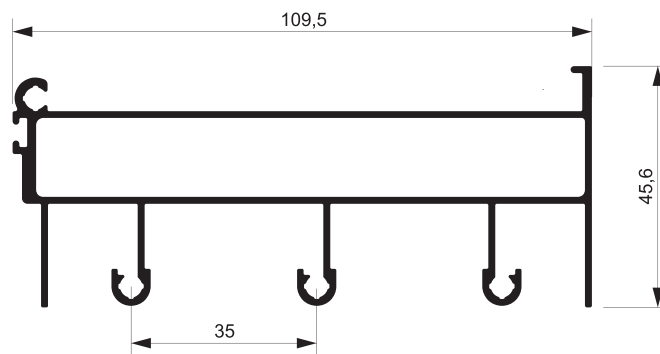

APF101

TRILHO SUPERIOR 3
PLANOS

1,486 Kg/m

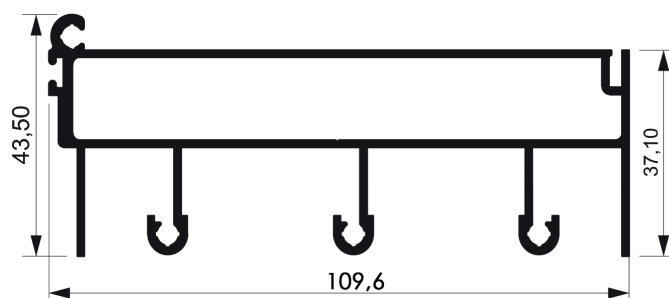

APF177

TRILHO INFERIOR 3 PLANOS

1,364 Kg/m

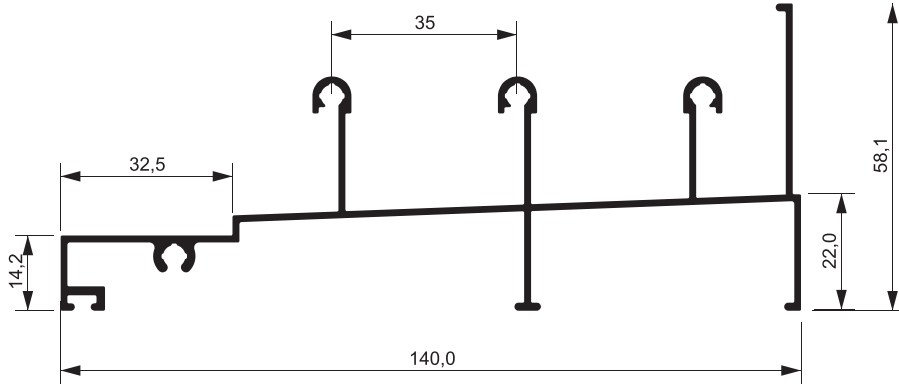

APF010

LATERAL LISA 2 PLANOS

0,534 Kg/m

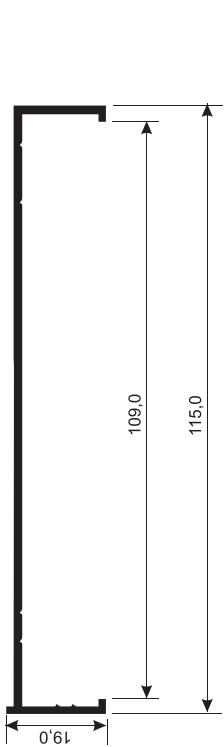

APF170

LATERAL LISA 3 PLANOS

0,746 Kg/m

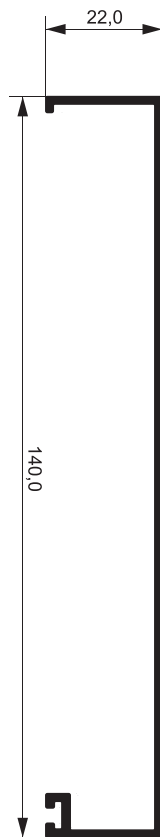

APF004

LATERAL RECOLHEDOR 2 PLANOS

0,940 Kg/m

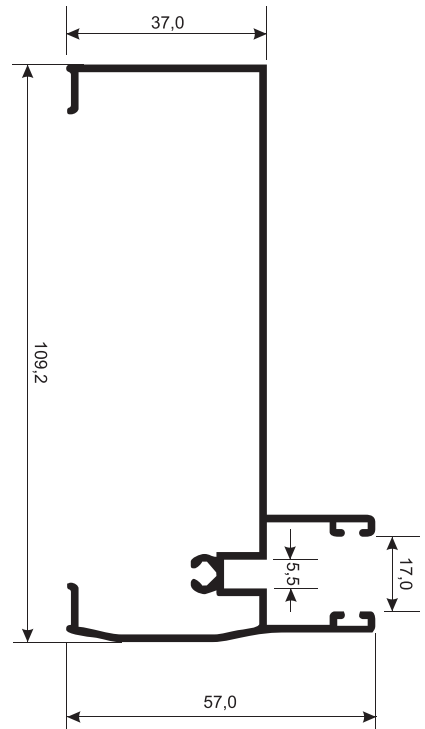

APF236

LATERAL RECOLHEDOR 3 PLANOS

1,185 Kg/m

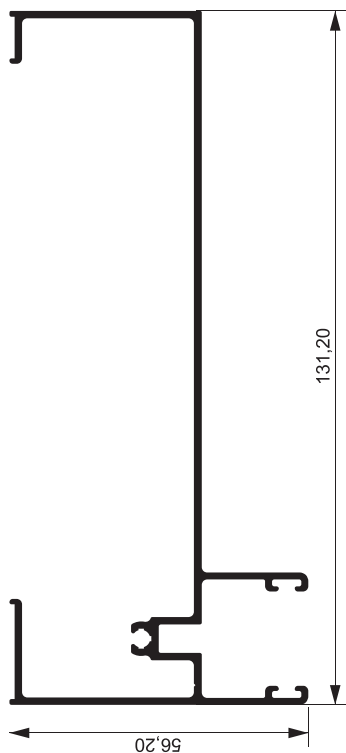

APF005

GUIA DA PERSIANA

0,641 Kg/m

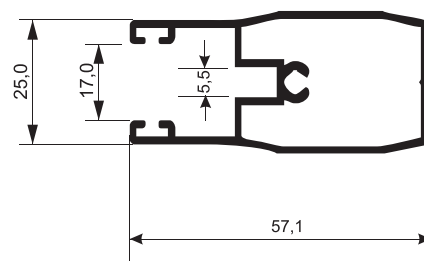

APF006

TAMPA INTERNA JANELA

0,831 Kg/m

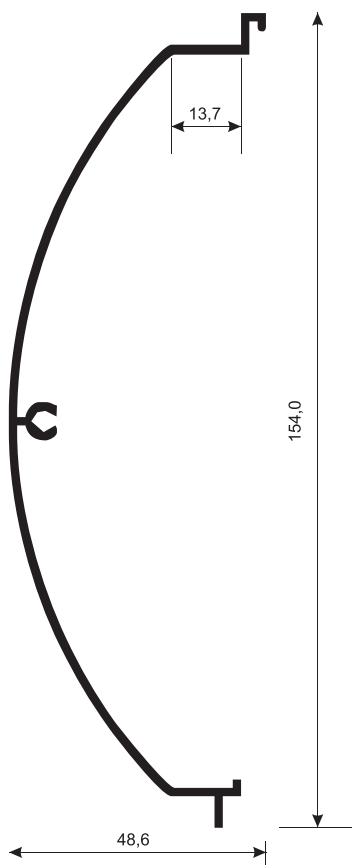

APF007

TAMPA EXTERNA JANELA

0,734 Kg/m

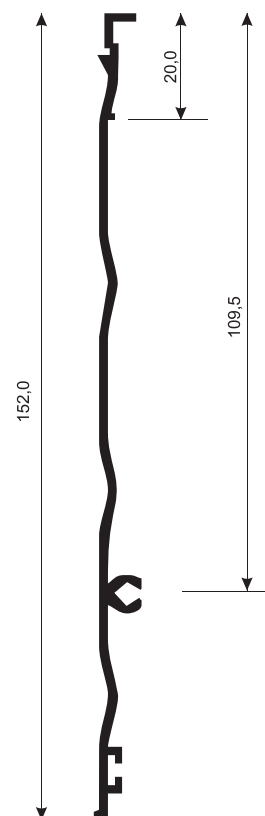

APF016

TAMPA INTERNA PORTA

1,289 Kg/m

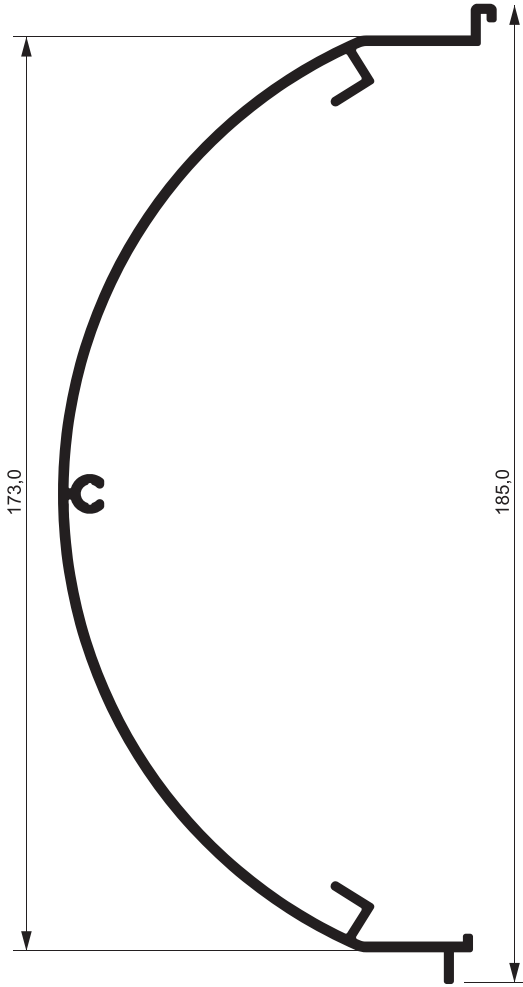

APF015

TAMPA EXTERNA PORTA

1,009 Kg/m

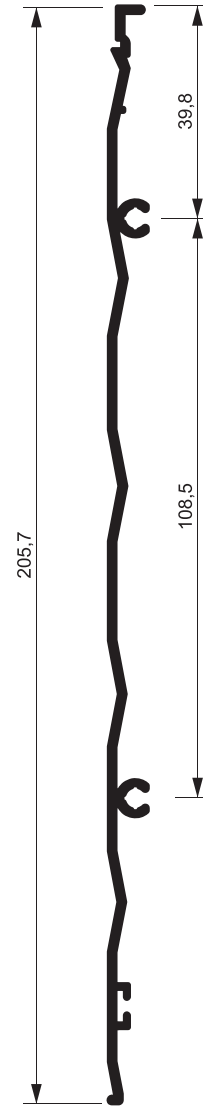

MG32063

EIXO INTEGRADA 40MM

0,441 kg/m

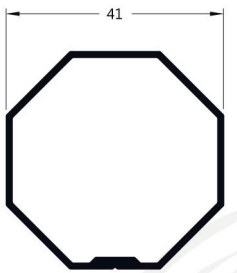

MG32032

EIXO INTEGRADA 60MM

0,881 kg/m

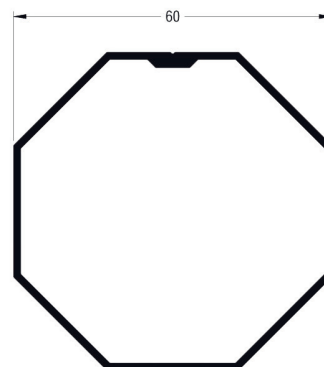

ESQUEMAS DE MONTAGEM

JANELA INTEGRADA 2 FOLHAS

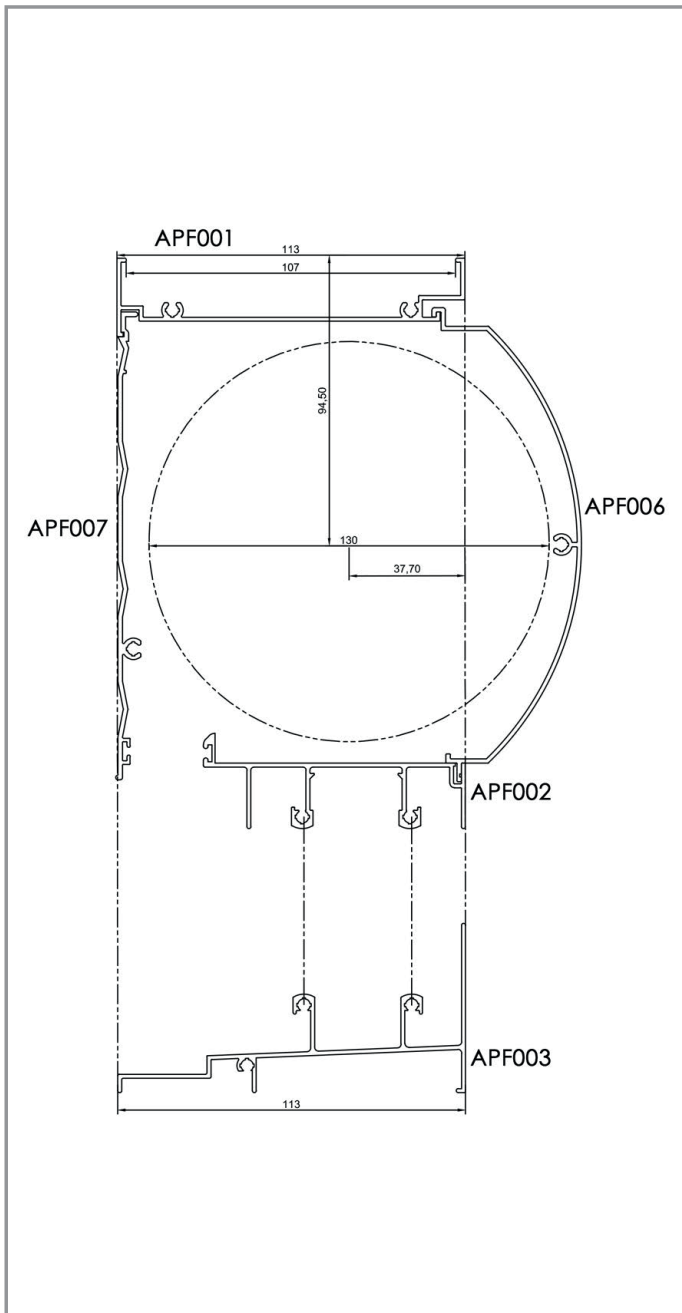

JANELA INTEGRADA 3 FOLHAS

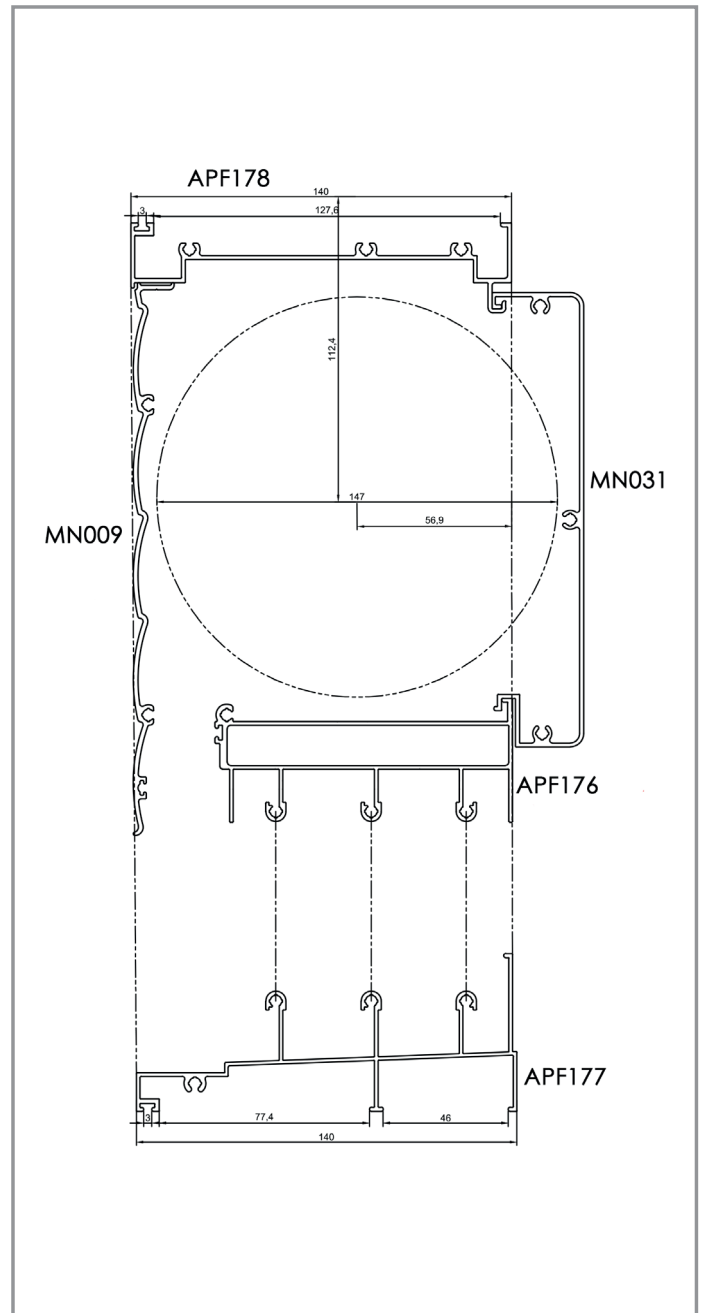

APF059

MARCO VERSÁTIL

1,503 Kg/m

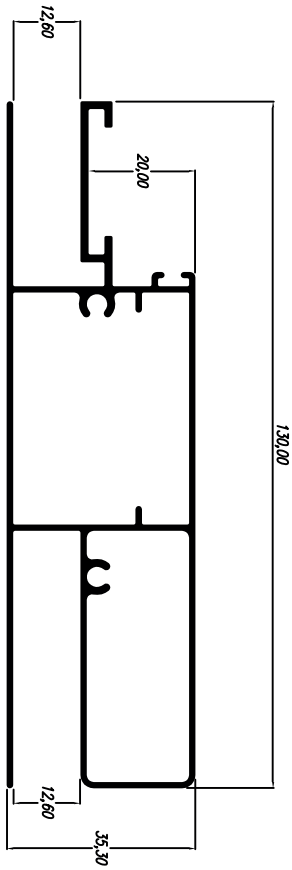

AP15

BATENTE E ACABAMENTO

0,152 Kg/m

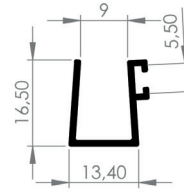

AP43

ACABAMENTO

0,079 Kg/m

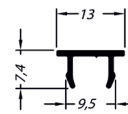

SU188

FRISO PARA LAMBRIL
150MM

0,545 Kg/m

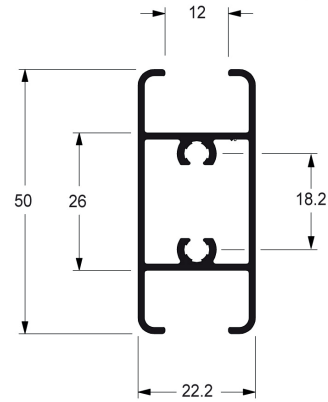

APF060

ARREIMATE COM
REGULAGEM

0,820 Kg/m

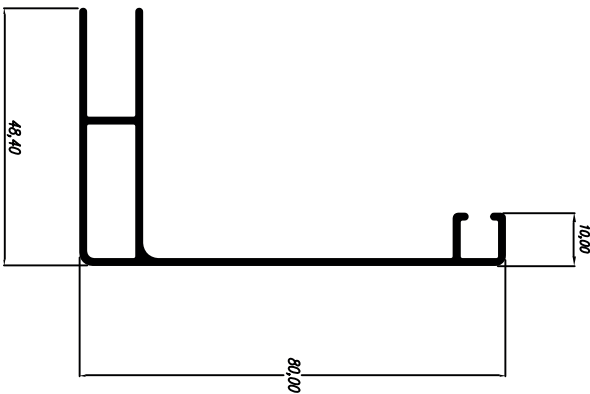

42106

FRISO PARA LAMBRIL
100MM

0,296 Kg/m

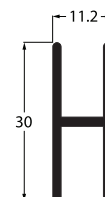

25548

MATA JUNTA

0,240 Kg/m

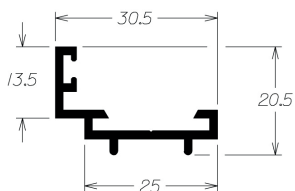

APF985

ADAPTADOR LINHA 30

0,355 Kg/m

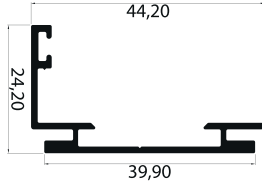

APF989

MARCO VERSATIL
INERNO

2,311 Kg/m

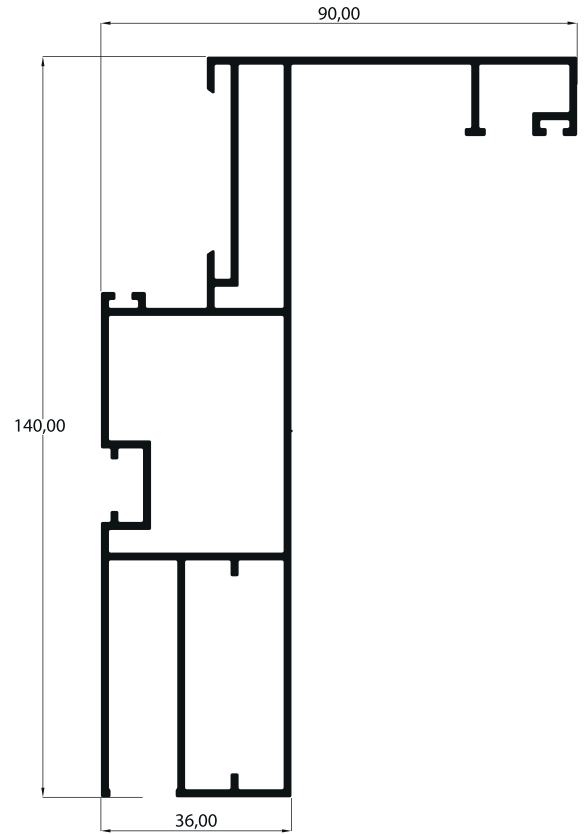

APF987

CLICK ACABAMENTO
PIVOTANTE

0,415 Kg/m

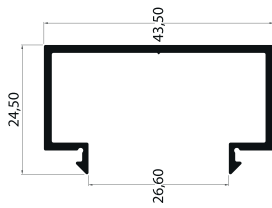

APF986

CLICK VEDAÇÃO E
BATENTE PIVOTANTE

0,215 Kg/m

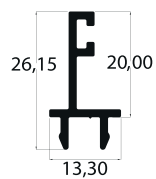

APF988

MARCO REGULAVEL
EXTERNO

1,031 Kg/m

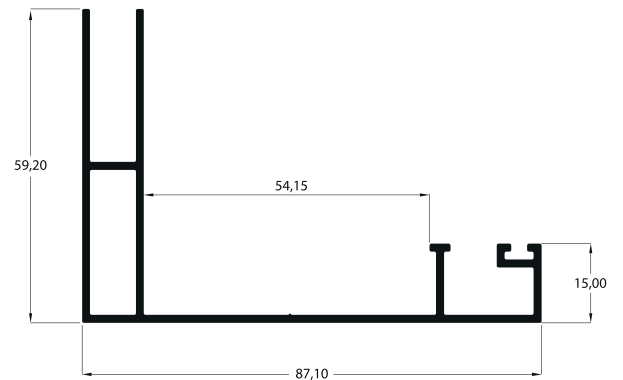

ALG042

MONTANTE

1,017 Kg/m

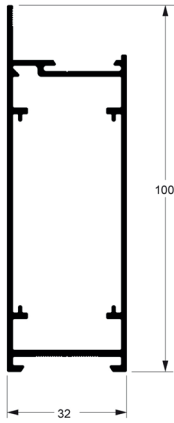

42173

MONTANTE LINHA 42

1,516 Kg/m

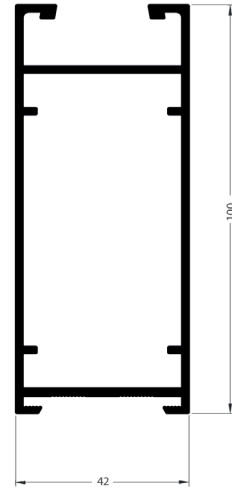

APF400

MONTANTE LINHA 30
SEM BAGUETE

1,049 Kg/m



30082

MONTANTE

0,962 Kg/m

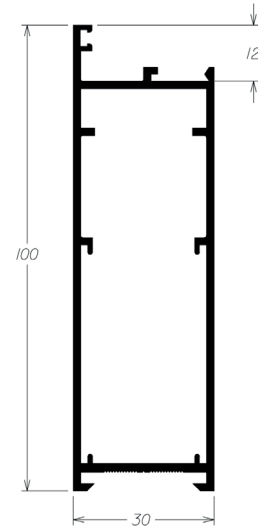

30083

MONTANTE LINHA 30
SEM BAGUETE

0,936 Kg/m

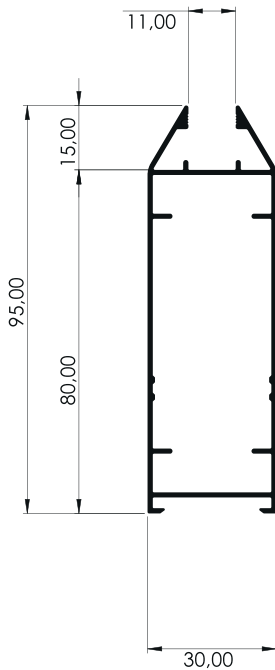

25400

MONTANTE LINHA 25
SEM BAGUETE

0,886 Kg/m

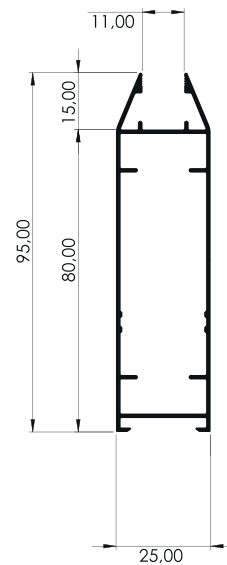

42165

LAMBRIL DUPLO

1,363 Kg/m

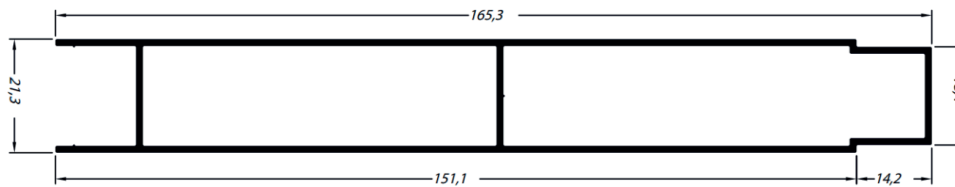

42174

LAMBRIL DUPLO 150MM

1,804 Kg/m

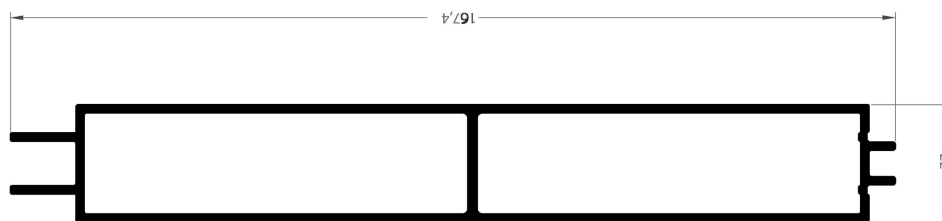

42175

LAMBRIL DUPLO 100MM

0,670 Kg/m

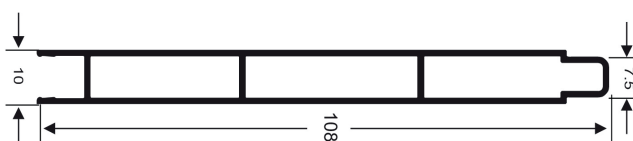

DS036

PORTA PALHETA

0,136 Kg/m

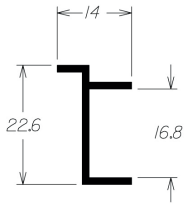

25016

MONTANTE

0,406 Kg/m

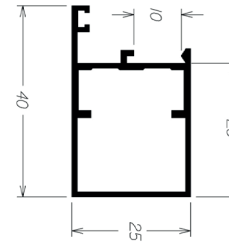

25021

BATENTE

0,222 Kg/m

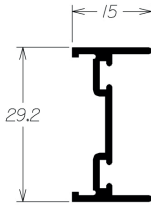

25542

MONTANTE

0,678 Kg/m

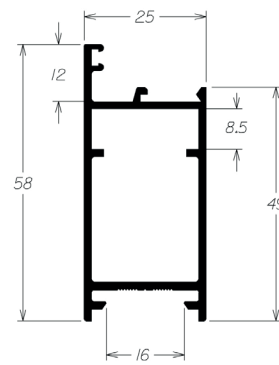

25504

MONTANTE

0,540 Kg/m

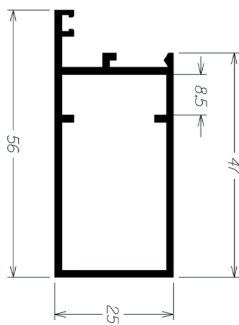

25508

TRAVESSA CENTRAL

0,595 Kg/m

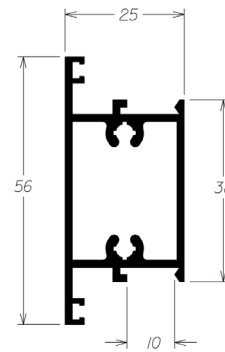

25026

TRAVESSA CENTRAL

0,480 Kg/m

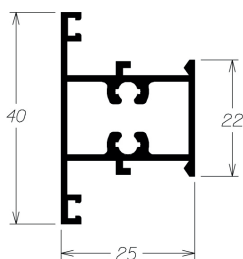

25540

MARCO

0,443 Kg/m

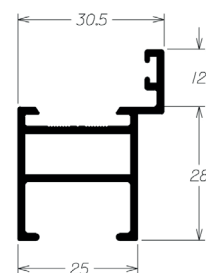

25548

MATA JUNTA

0,240 Kg/m

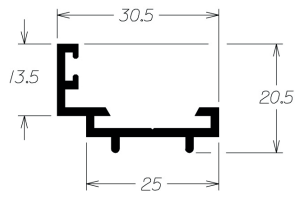

25025

MONTANTE PARA
BASCULANTE

0,286 Kg/m

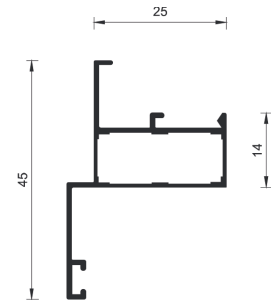

25001

MONTANTE

0,260 Kg/m

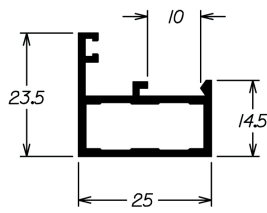

BG001

BAGUETE

0,093Kg/m

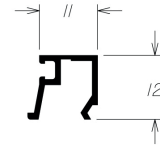

25002

MARCO LISO

0,335 Kg/m

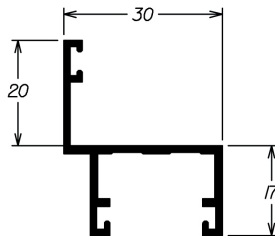

25514

MARCO LATERAL LISO

0,472 Kg/m

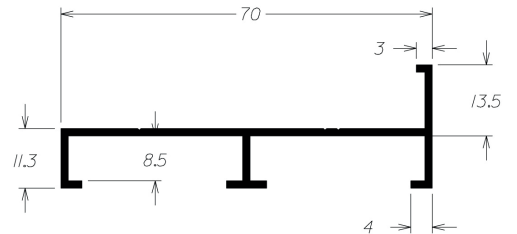

FC070

COLUNA CENTRAL

0,773 Kg/m

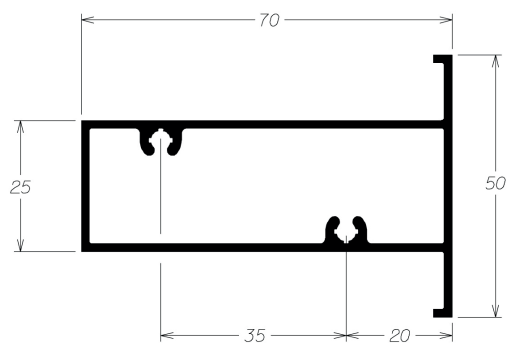

25677

MATA JUNTA LISA

0,196 Kg/m

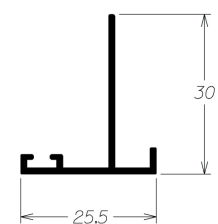

SU110

TRAVESSA SUPERIOR E
INFERIOR

0,514 Kg/m

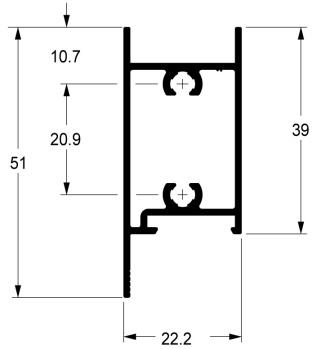

SU111

MONTANTE DA FOLHA

0,563 Kg/m

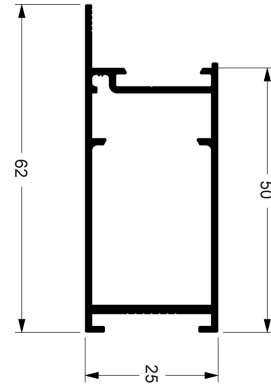

SU279

MARCO DA PORTA

0,508 Kg/m

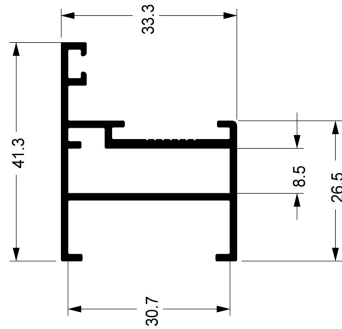

SU188

TRAVESSA CENTRAL SEM
BAGUETE

0,586 Kg/m

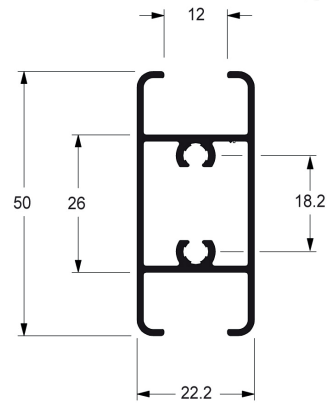

SU241

MONTANTE DA FOLHA
SEM BAGUETE

0,686 Kg/m

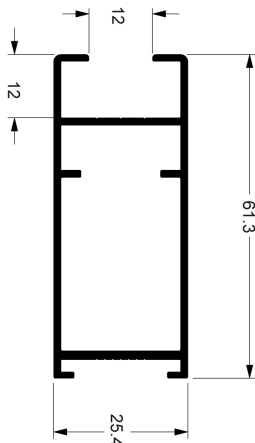

SU102

BAGUETE

0,106 Kg/m

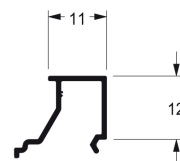

SU300

TRAVESSA SUPERIOR E
INFERIOR

0.766 Kg/m

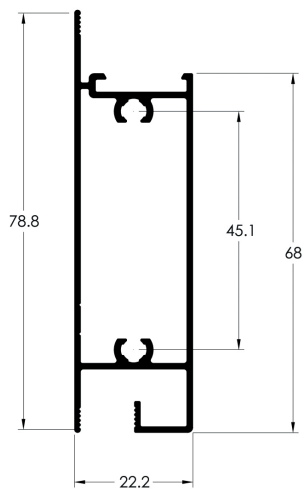

SU227

TRAVESSA CENTRAL

0.524 Kg/m

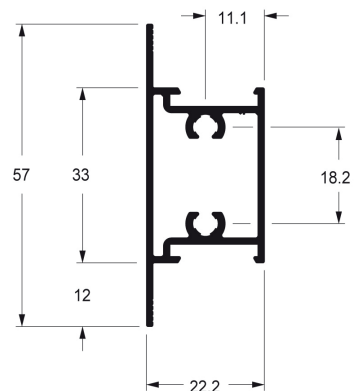

ME074

MARCO COM OLHAL

0,598 Kg/m

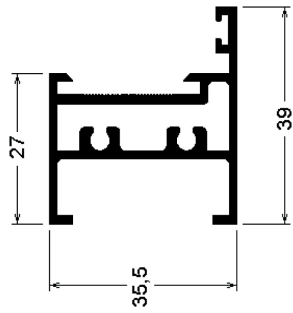

ME075

MONTANTE

0,612 Kg/m

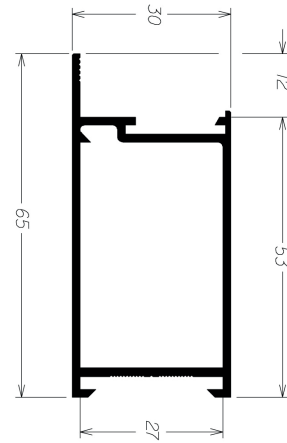

ME076

MONTANTE COM
BATENTE

0,743 Kg/m

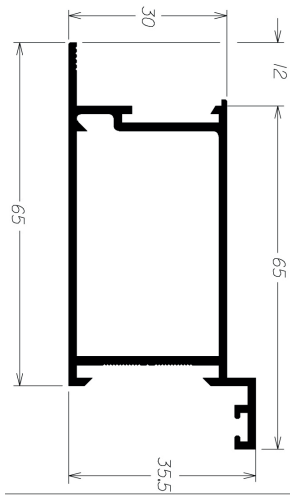

ME077

MONTANTE COM
BATENTE

0,688 Kg/m

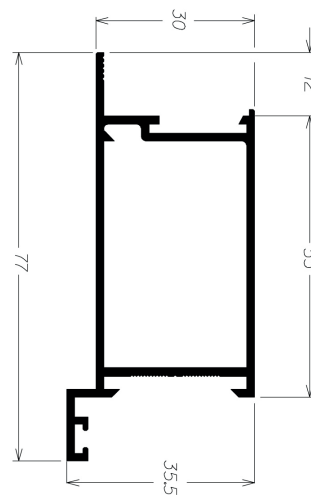

ME078

TRAVESSA SUPERIOR E
INFERIOR

1,109 Kg/m

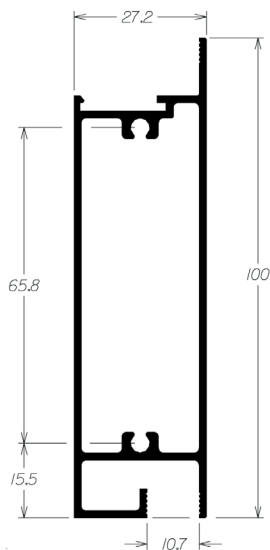

ME024

GUIA INFERIOR

0,356 Kg/m

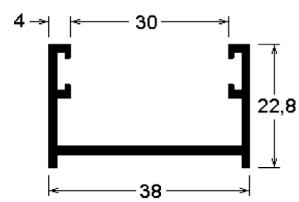

ME086

0,126 Kg/m

BAGUETE

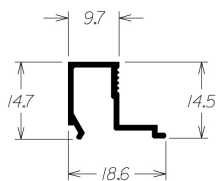

ME079

0,131 Kg/m

BAGUETE

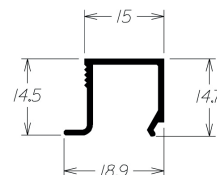

ME183

0,555 Kg/m

MARCO DA PORTA

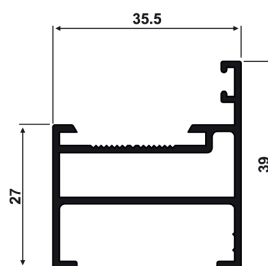

30082

MONTANTE

1,195 Kg/m

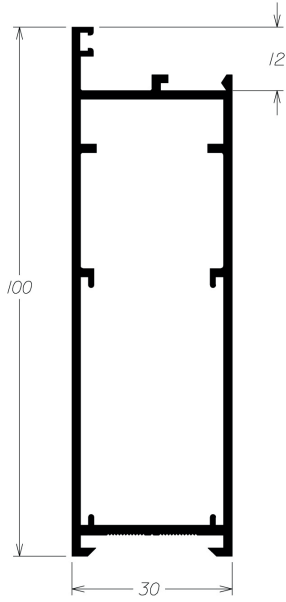

30083

MONTANTE LINHA 30
SEM BAGUETE

0,936 Kg/m

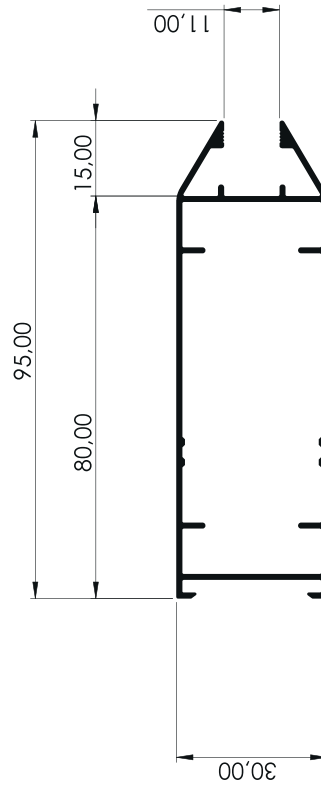

30026

MONTANTE

0,681 Kg/m

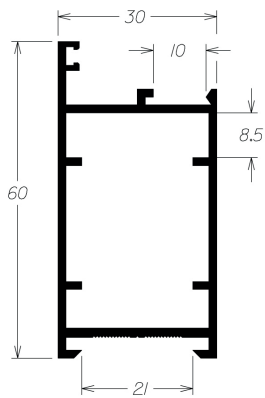

30030

TRAVESSA CENTRAL

1,157 Kg/m

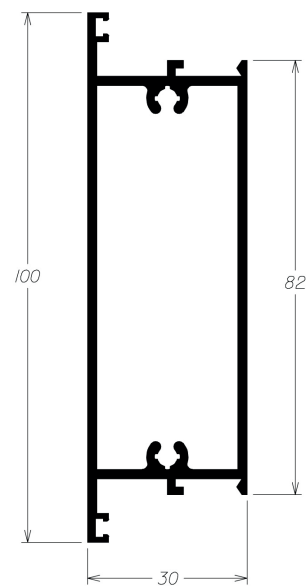

30019

BATENTE

0,295 Kg/m

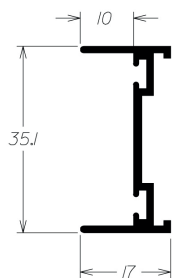

30034

MATA JUNTA

0,257 Kg/m

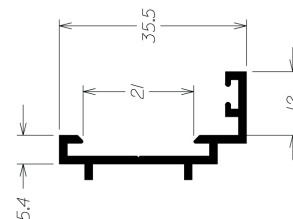

30023

MARCO DA PORTA

0,558 Kg/m

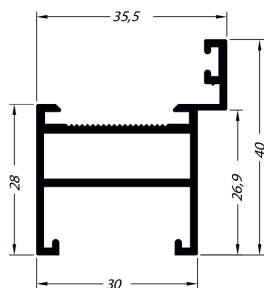

30025

TRAVESSA CENTRAL

0,682 Kg/m

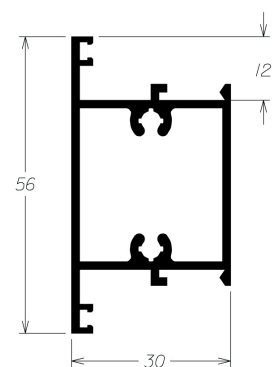

VZ037

PORTA PALHETA

0,166 Kg/m

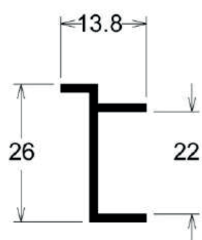

BG010

BAGUETE

0,136 Kg/m

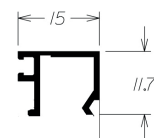

ALG056

MARCO

0,599 Kg/m

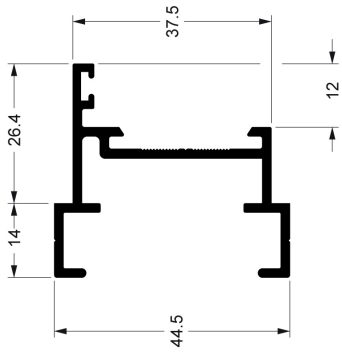

ALG043

MONTANTE

0,815 Kg/m

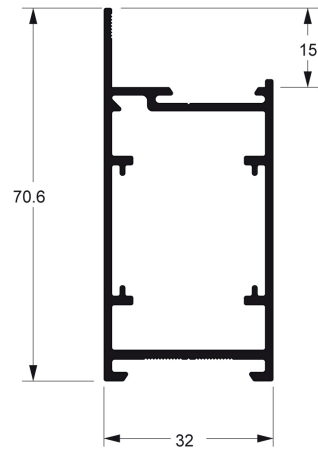

ALG042

MONTANTE

1,017 Kg/m

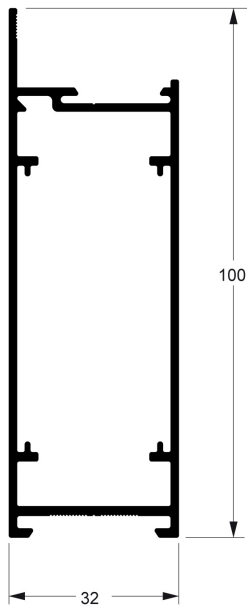

ALG055

TRAVESSA CENTRAL

0,704 Kg/m

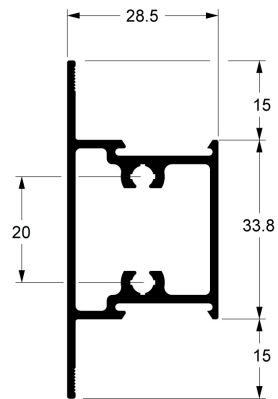

ALG016

MATA JUNTA

0,336 Kg/m

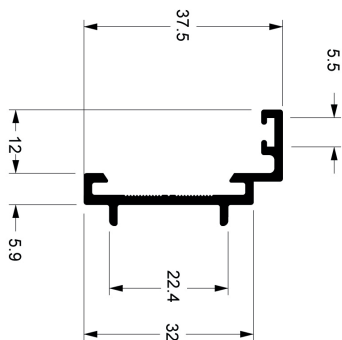

ALG059

BAGUETE

0,157 Kg/m

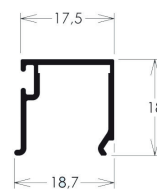

42014

MATA JUNTA

0,367 Kg/m

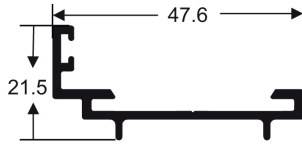

42012

MARCO

0,835 Kg/m

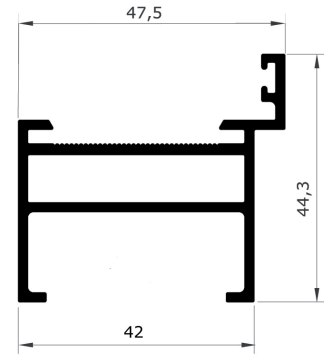

42173

MONTANTE SEM BAGUETE

1,510 Kg/m

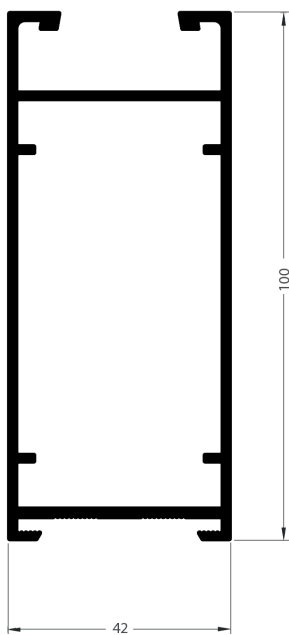

42035

MONTANTE

1,510 Kg/m

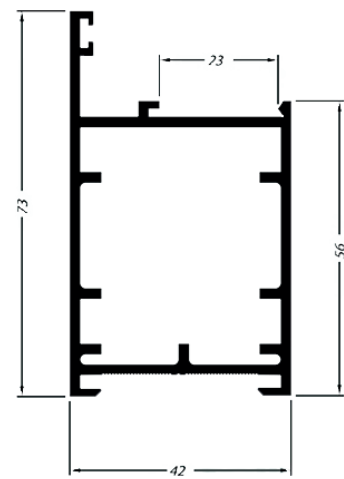

ITEM SOB CONSULTA

42032

MONTANTE

1,367 Kg/m

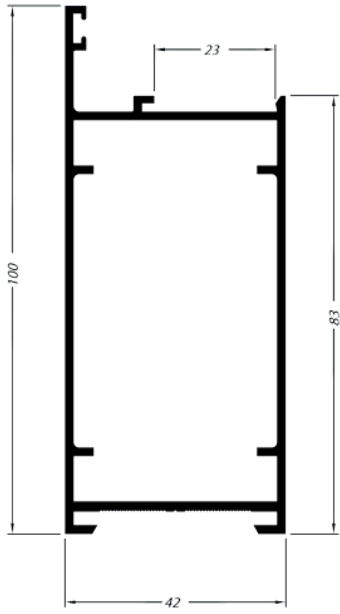

42007

TRAVESSA CENTRAL

1,336 Kg/m

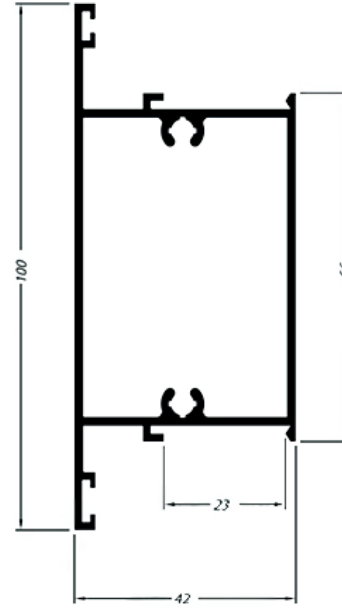

BG037

BAGUETE 22MM

0,189 Kg/m

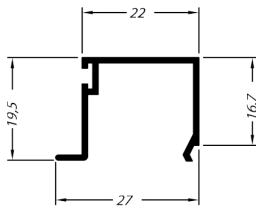

BG040

BAGUETE 25MM

0,209 Kg/m

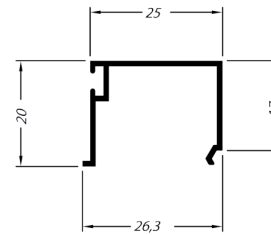

ITEM SOB CONSULTA

VZ006

VENEZIANA SEM
VENTILACÃO 22MM

0,269 Kg/m

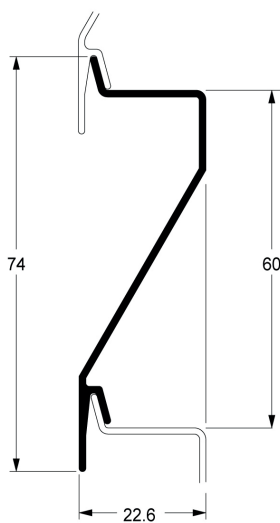

US285

VENEZIANA COM
VENTILACÃO 22MM

0,269 Kg/m

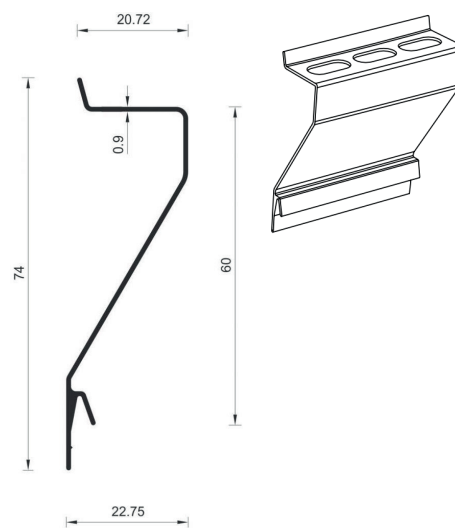

VZ051

VENEZIANA SEM
VENTILACAO 12MM

0,245 Kg/m

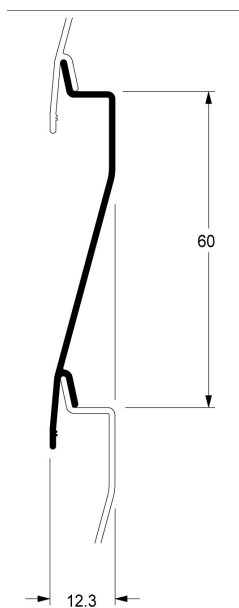

US294

VENEZIANA COM
VENTILACAO 12MM

0,245 Kg/m

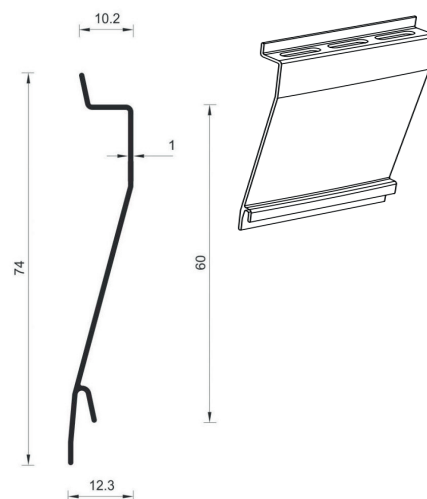

VZ023

VENEZIANA SEM
VENTILACÃO 16MM

0,293 Kg/m

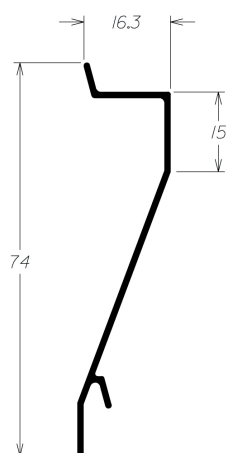

US282

VENEZIANA COM
VENTILACÃO 16MM

0,242 Kg/m

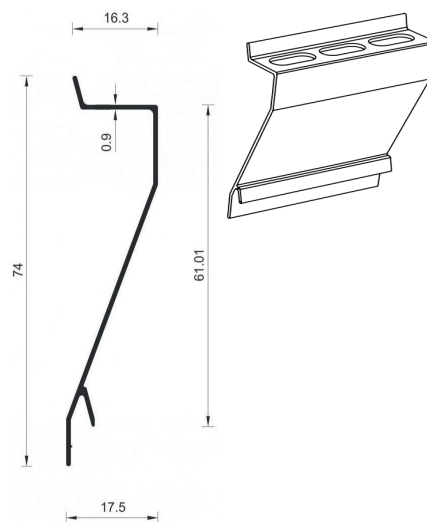

VZ528 / US528

VENEZIANA 22MM -
Mega 25

0,323 Kg/m

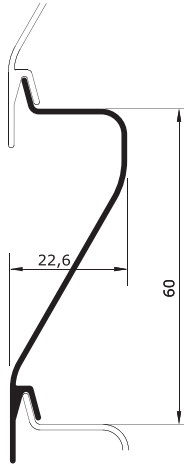

COM E SEM
VENTILAÇÃO

VZ017 / US017

VENEZIANA 16MM -
Mega 25

0,274 Kg/m

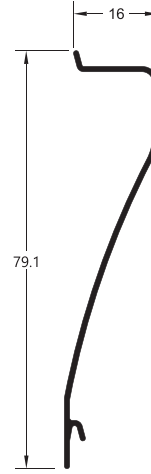

COM E SEM
VENTILAÇÃO

VZ049

VENEZIANA TERMINAL DE
DUTO

0,301 Kg/m

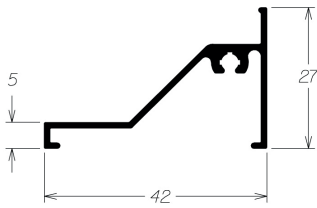

VZ047

VENEZIANA DUTO

0,271 Kg/m

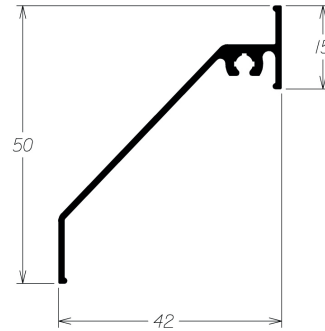

VZ060

VENEZIANA DUTO

0,326 Kg/m

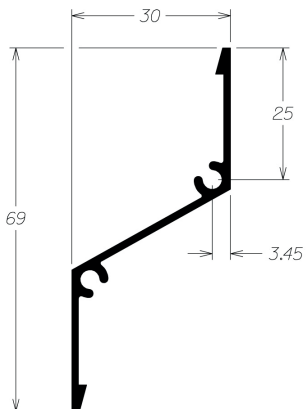

VZ032

VENEZIANA COLONIAL

0,415 Kg/m

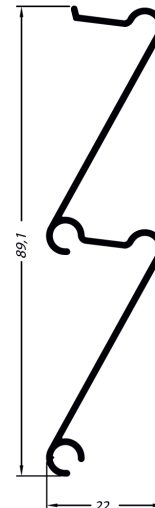

VZ002

0,230 Kg/m

MONTANTE PARA VZ001

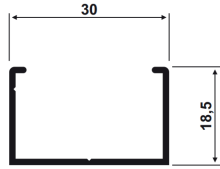

VZ001

0,419 Kg/m

VENEZIANA ORIENTÁVEL

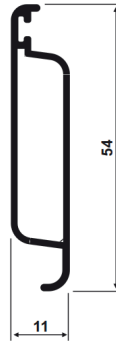

LB036

LAMBRIL LISO

0,707 Kg/m

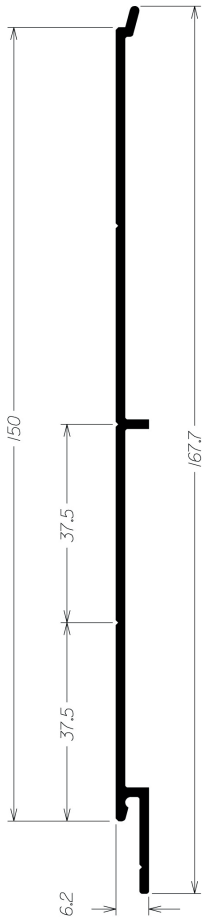

LB050

LAMBRIL FRISADO

0,577 Kg/m

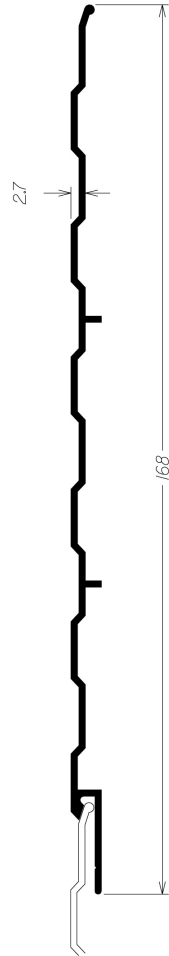

LB038

LAMBRIL BUZIOS

0,707 Kg/m

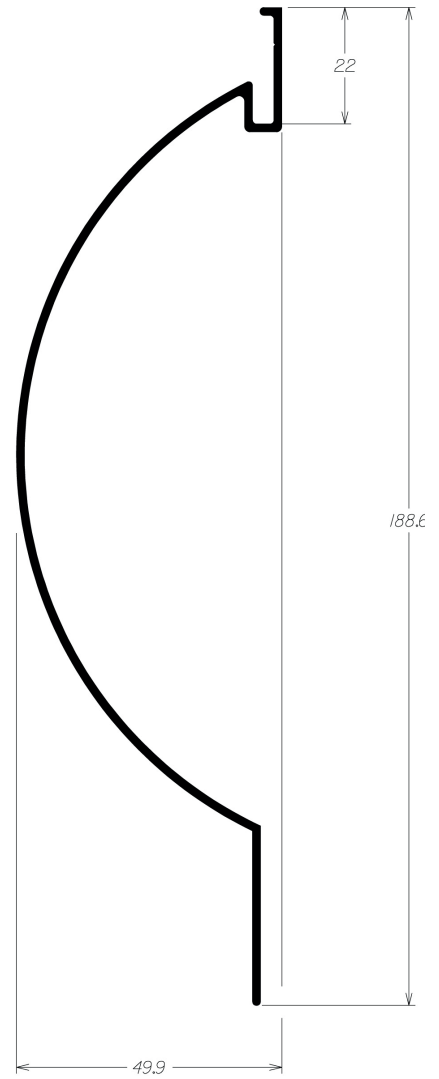

42175

LAMBRIL DUPLO

0,670 Kg/m

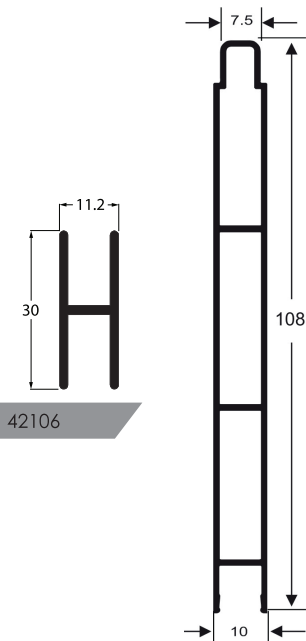

42106

42177

LAMBRIL DUPLO

0,795 Kg/m

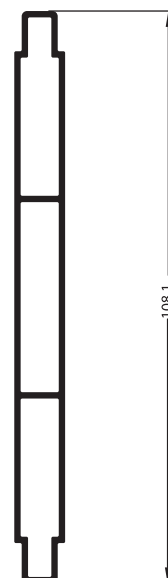

42174

LAMBRIL DUPLO

1,804 Kg/m

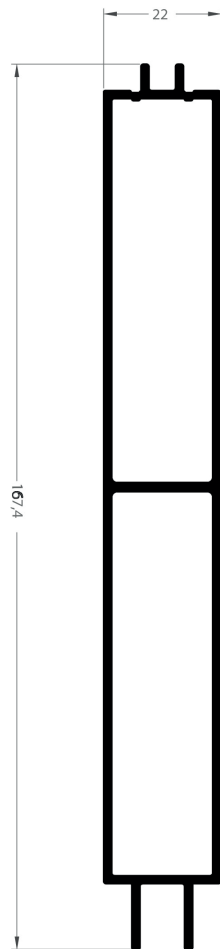

42176

LAMBRIL DUPLO

2,258 Kg/m

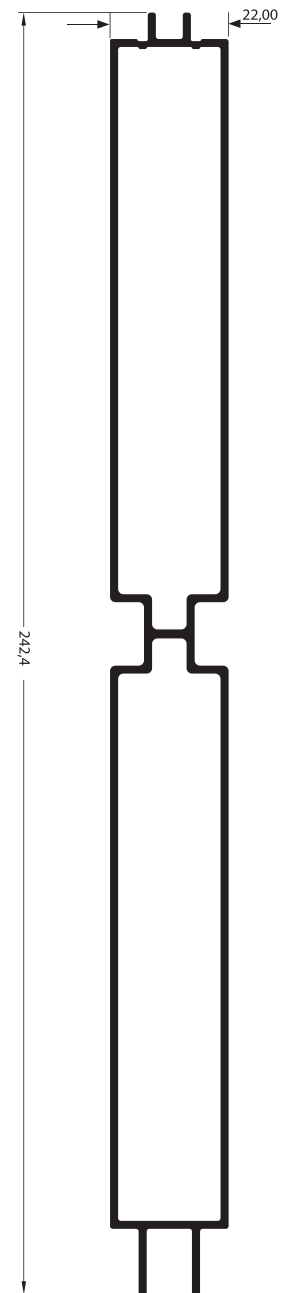

42165

LAMBRIL DUPLO

1,363 Kg/m

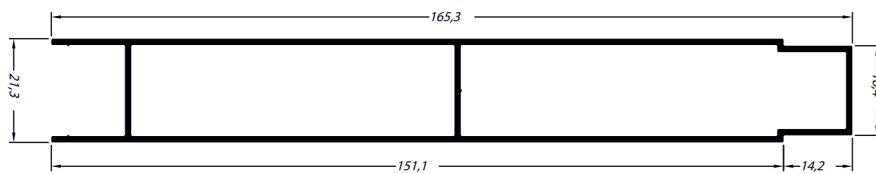

42166

FRISO PARA LAMBRIL

0,555 Kg/m

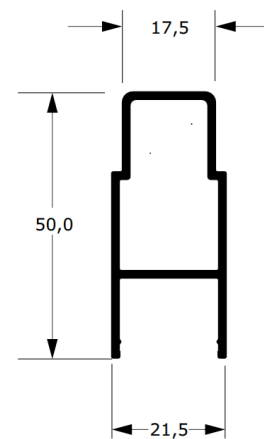

DC004

BRISE TUBULAR

1,230 Kg/m

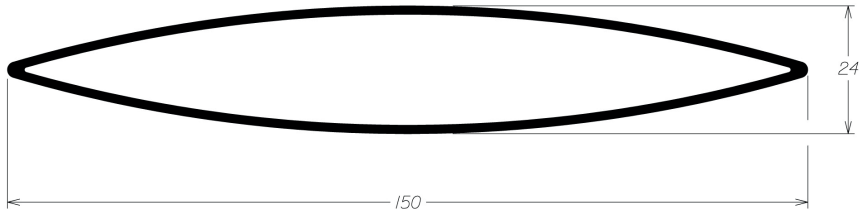

DC006

BRISE SOLIDO

0,835 Kg/m

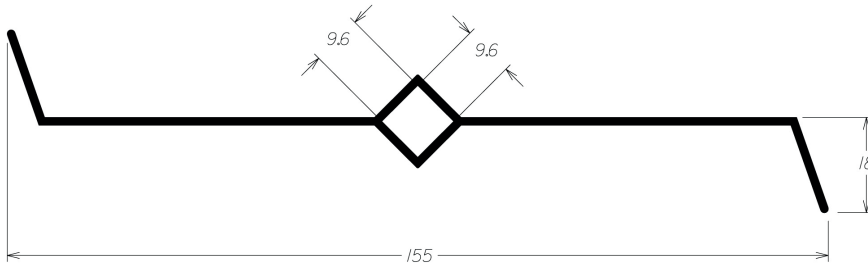

PC081

PERFIL PARA PORTÃO

0,646 Kg/m

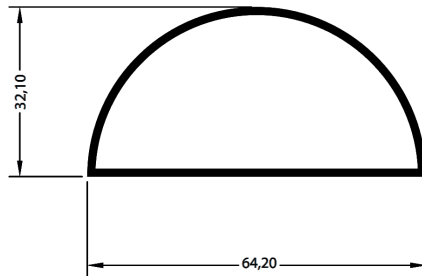

PC002

TUBO RETANGULAR

0,517 Kg/m

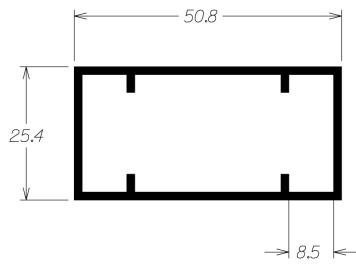

PC003

TUBO RETANGULAR

0,978 Kg/m

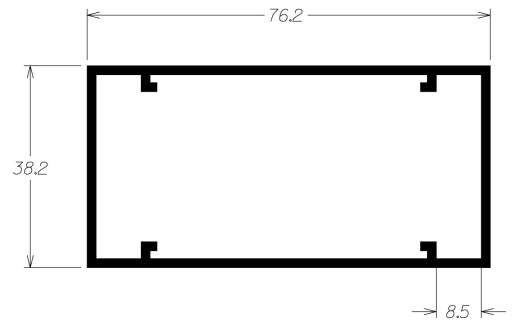

PC004

TUBO RETANGULAR

0,560 Kg/m

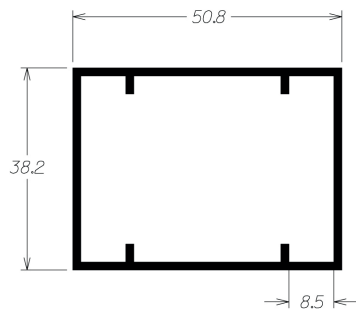

PC010

MONTANTE DO QUADRO

0,986 Kg/m

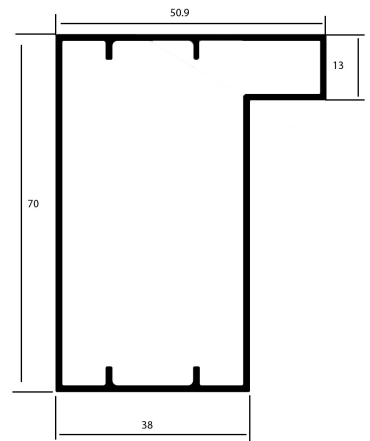

PC073

TRAVESSA DE PORTÃO

1,198 Kg/m

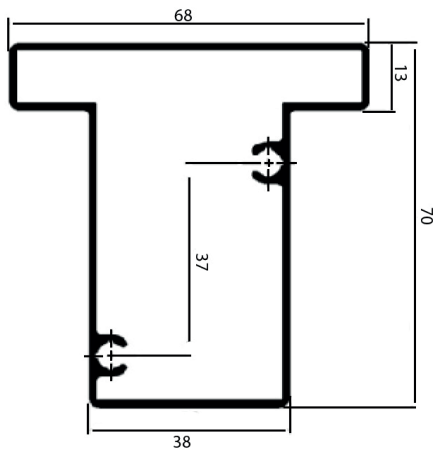

PC006

TRILHO INFERIOR

0,403 Kg/m

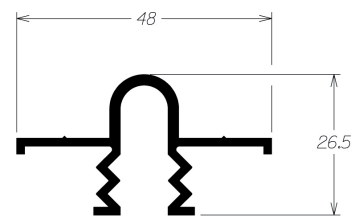

PC719

TUBO RETANGULAR

1,470 Kg/m



PC123

TAMPA DA CAIXA

1,372 Kg/m

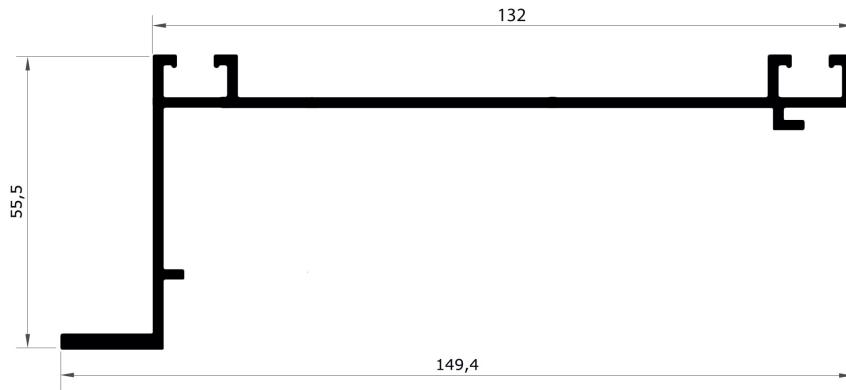

PC124

CAIXA DO PORTÃO

2,931 Kg/m

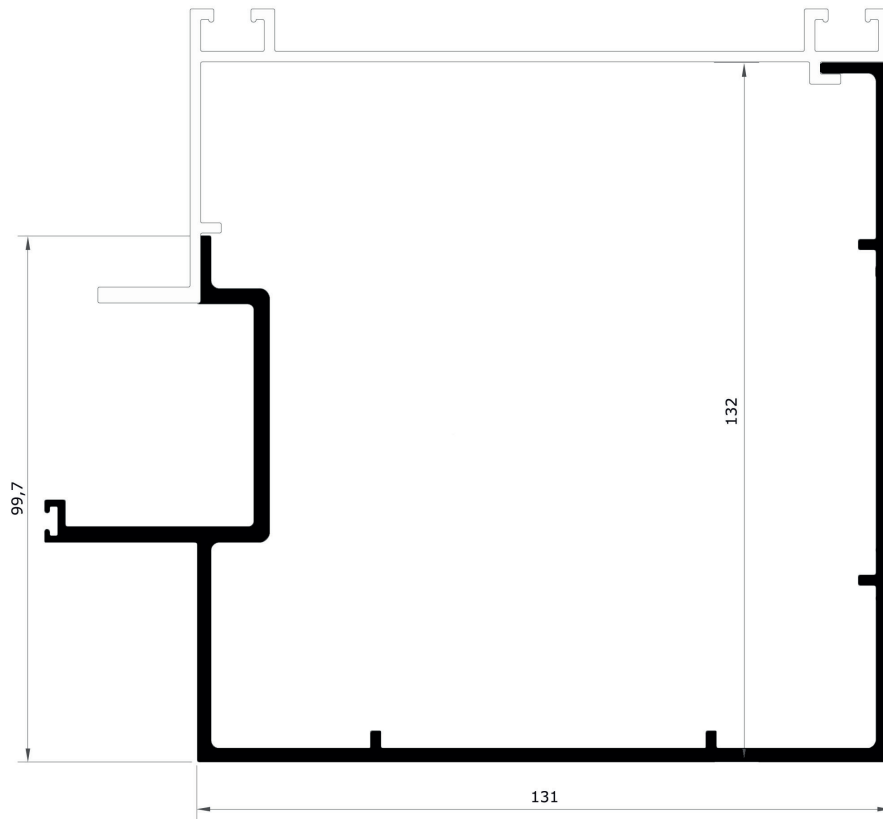

PC125

TAMPA DA CAIXA

0,894 Kg/m

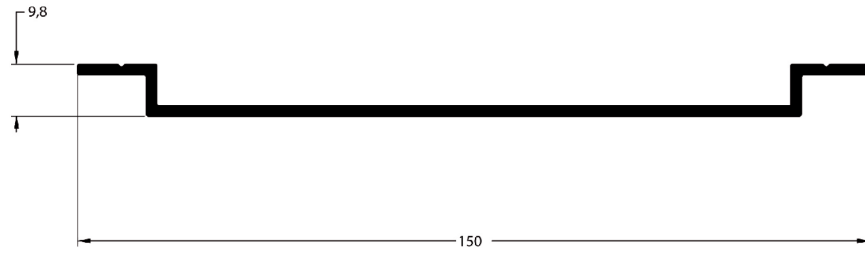

PC126

CAIXA DO PORTÃO

4,349 Kg/m

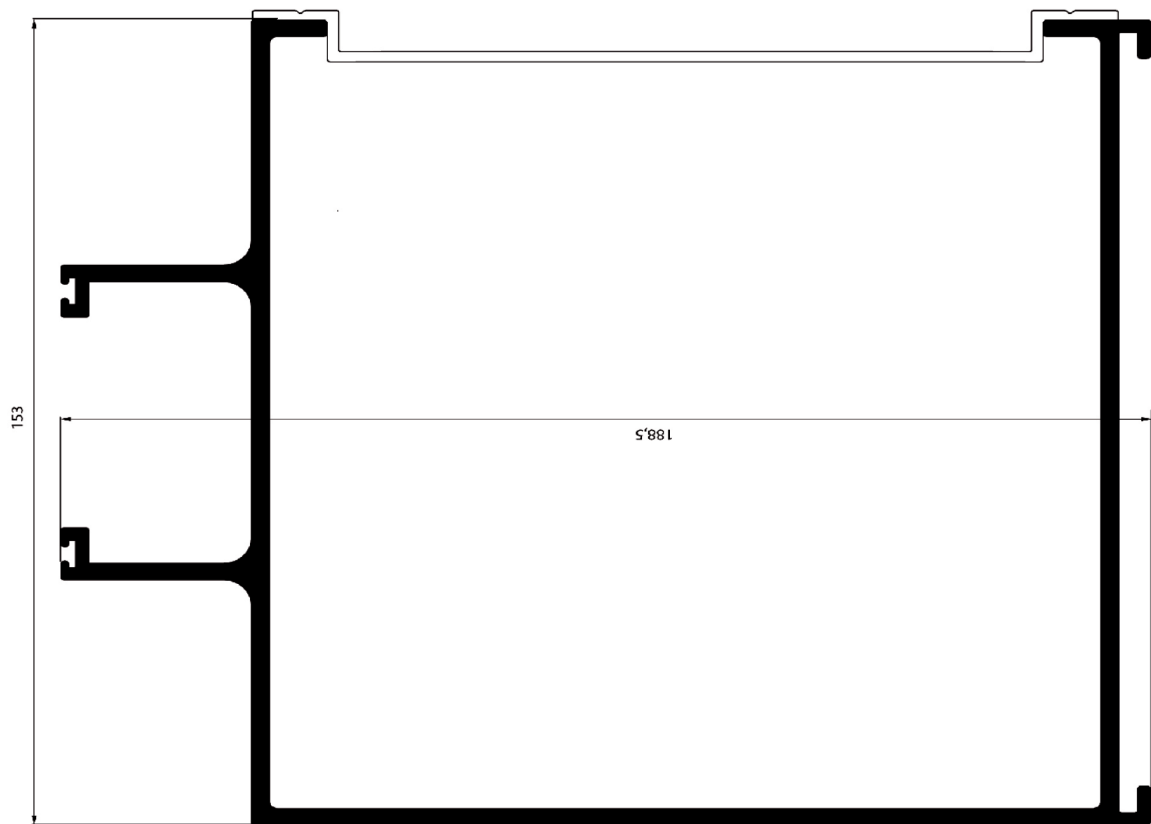

AP37A

TRILHO SUPERIOR
STANLEY COM ABA

0,791 Kg/m

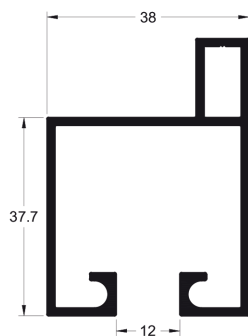

CG104

TUBO COM BOCAL

0,794 Kg/m

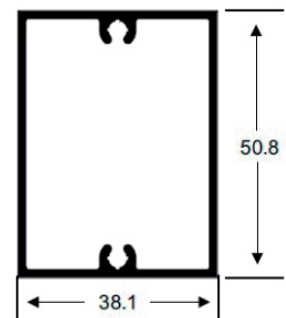

SU001
TRILHO SUPERIOR 2 PLANOS

0,696 Kg/m

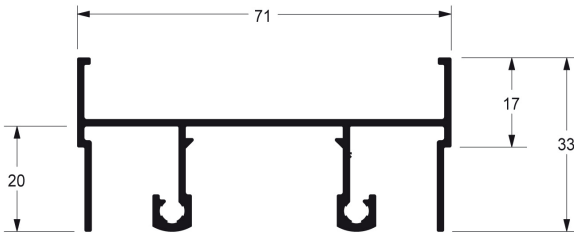

SU002
TRILHO INFERIOR JANELA 2 PLANOS

0,660 Kg/m

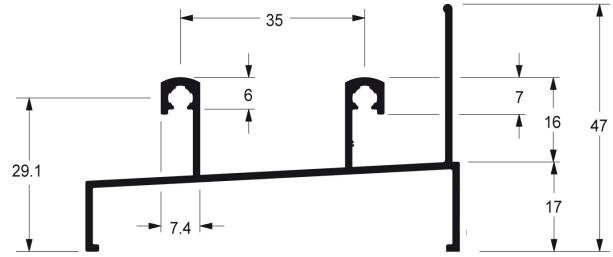

APG002
TRILHO INFERIOR JANELA 2 PLANOS

0,695 Kg/m

MGT-2586

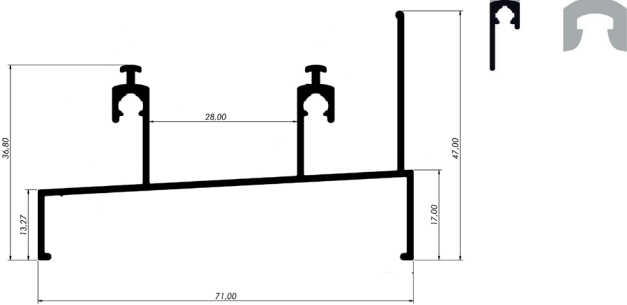

SU228
TRILHO INFERIOR PORTA 2 PLANOS

0,688 Kg/m

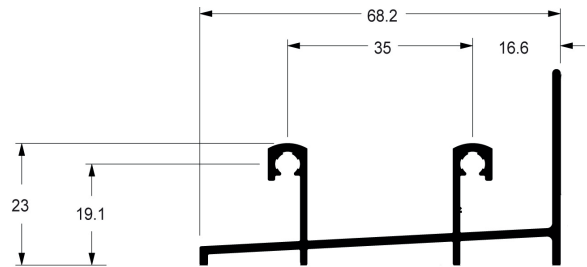

APG228
TRILHO INFERIOR PORTA 2 PLANOS

0,666 Kg/m

MGT-2586

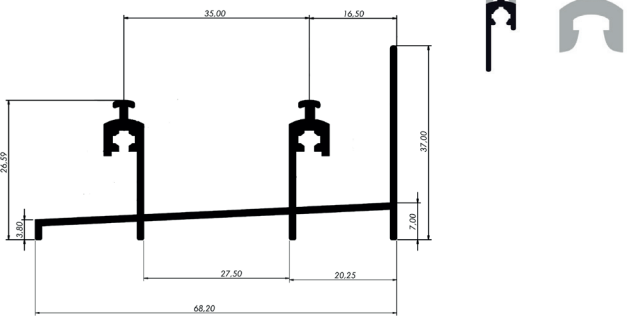

SU003
MARCO LATERAL 2 PLANOS

0,489 Kg/m

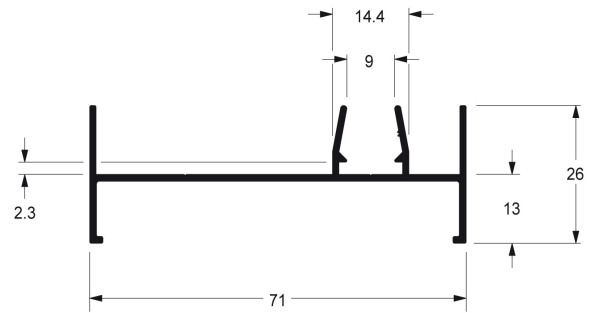

SU004
MARCO BANDEIRA DE PEITORIL

0,426 Kg/m

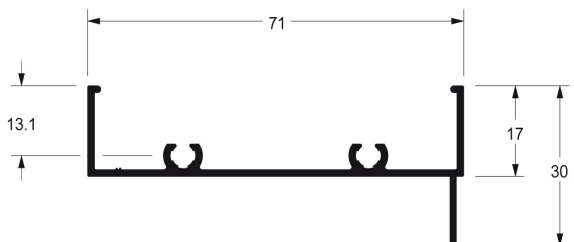

SU005
TRAVESSA BANDEIRA FIXA

0,905 Kg/m

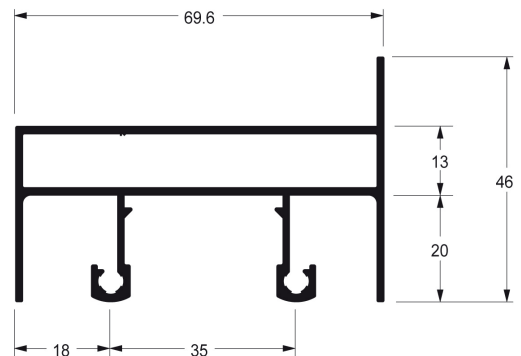

SU006

0,845 Kg/m

TRAVESSA PEITORIL FIXO

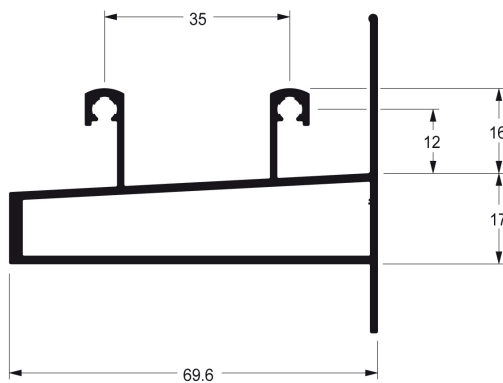

SU007

0,357 Kg/m

MARCO LATERAL 2 PLANOS

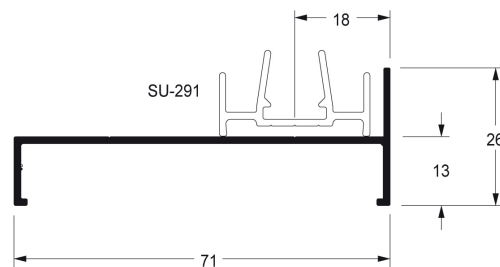

SU010

0,951 Kg/m

TRILHO SUPERIOR 3 PLANOS

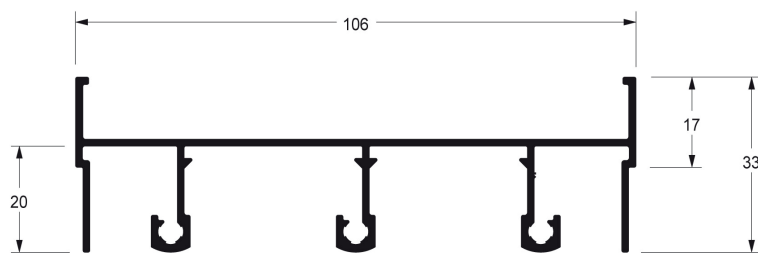

SU011

0,894 Kg/m

TRILHO INFERIOR JANELA 3 PLANOS

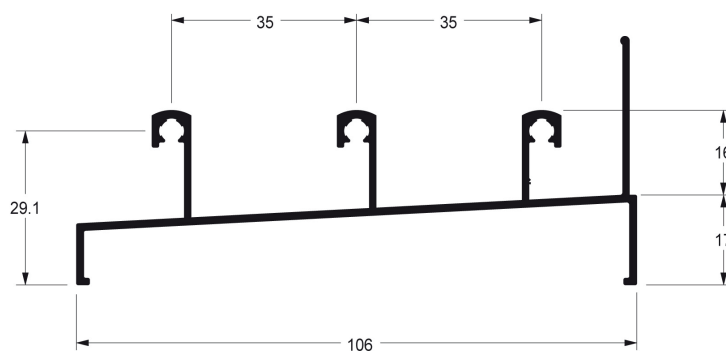

APG011
TRILHO INFERIOR JANELA
3 PLANOS

0,944 Kg/m

MGT-2586

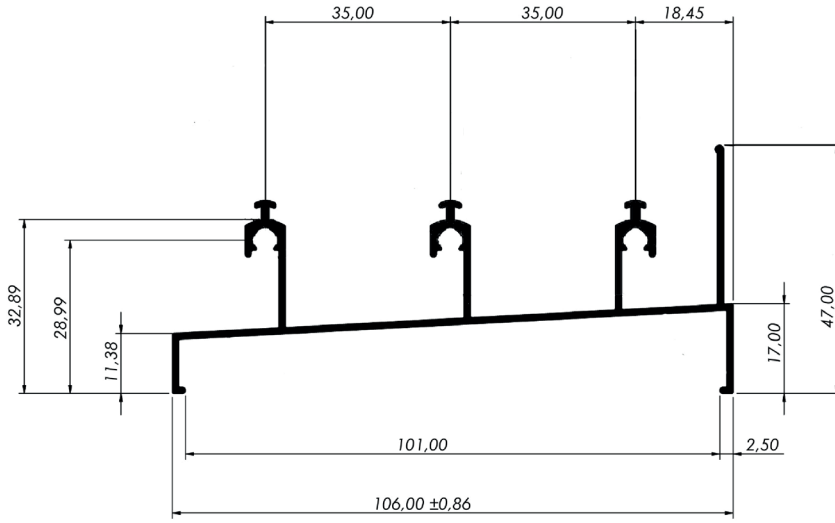

SU230
TRILHO INFERIOR PORTA 3
PLANOS

0,831 Kg/m

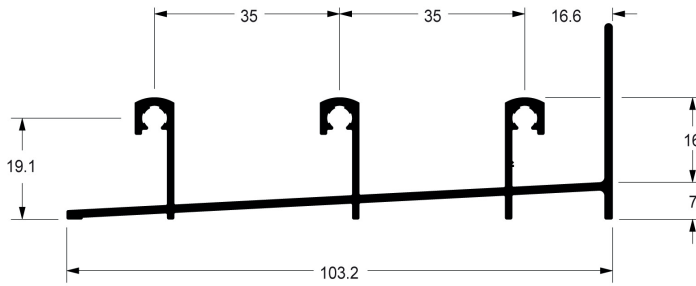

APG230
TRILHO INFERIOR PORTA 3
PLANOS

0,895 Kg/m

MGT-2586

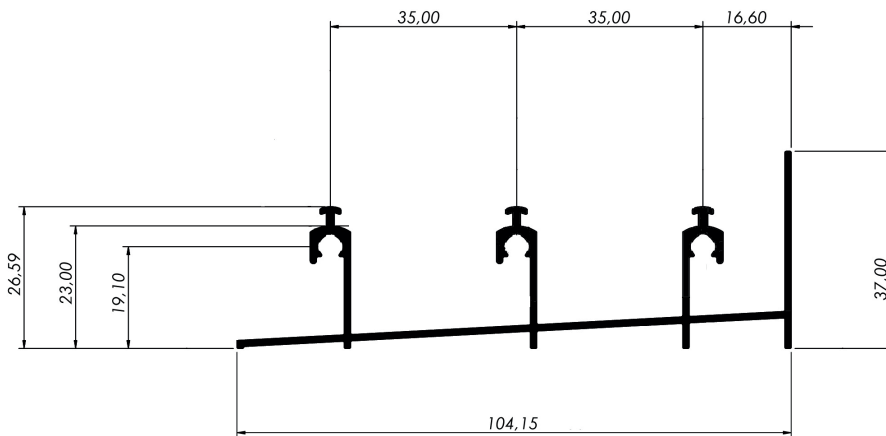

SU012

MARCO LATERAL LISO 3
PLANOS

0,470 Kg/m

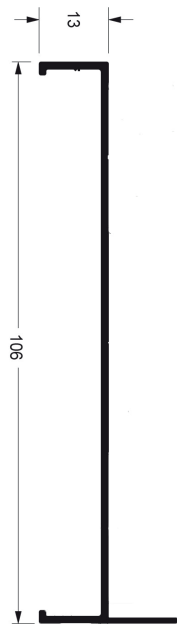

SU013

MARCO LATERAL 3
PLANOS

0,671 Kg/m

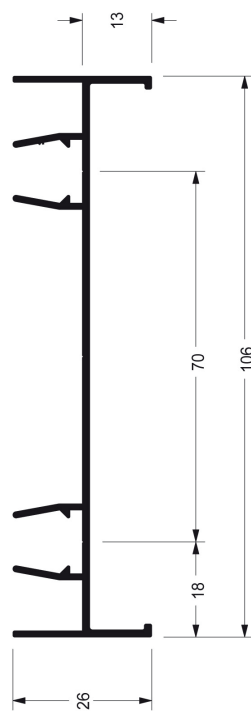

SU014

MARCO LATERAL 3
PLANOS

0,569 Kg/m

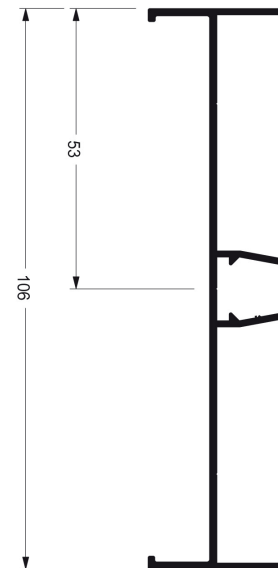

SU018

MARCO SUPERIOR
BANDEIRA

0,580 Kg/m

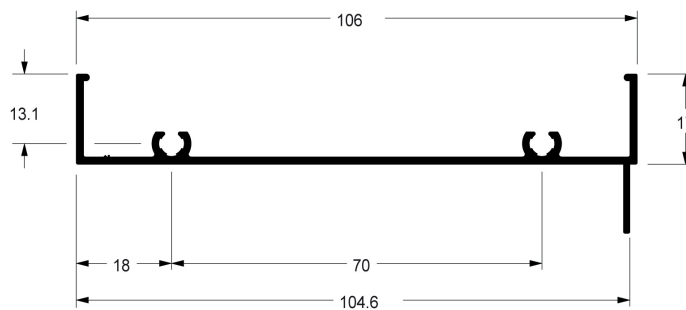

SU019

TRAVESSA DA BANDEIRA
3 PLANOS

1,678 Kg/m

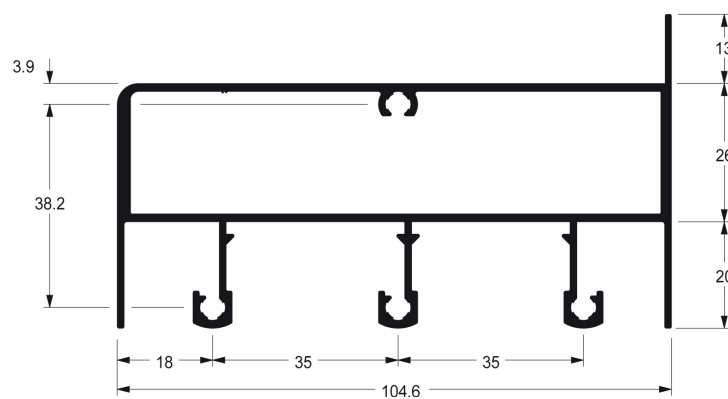

SU121

TRILHO SUPERIOR 4
PLANOS

1,302 Kg/m

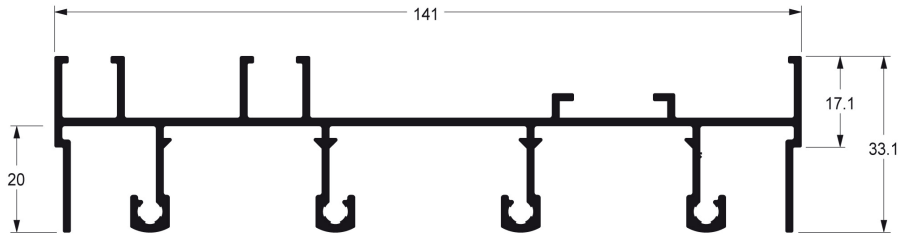

SU122

TRILHO INFERIOR 4
PLANOS

1,383 Kg/m

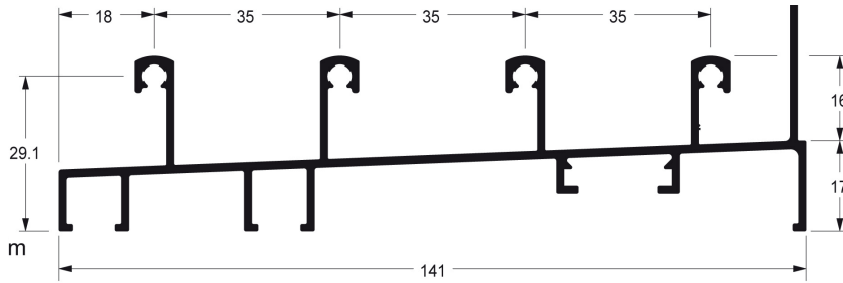

SU123

MARCO LATERAL LISO 4
PLANOS

0,751 Kg/m

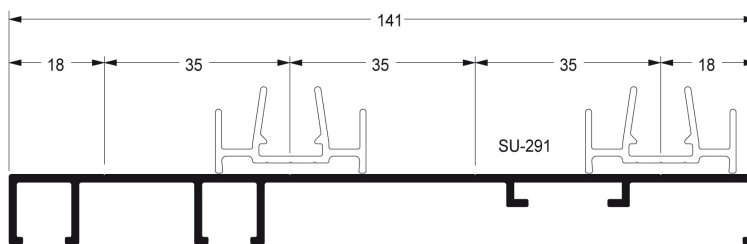

SU124

TRILHO INFERIOR PORTA 4
PLANOS

1,181 Kg/m

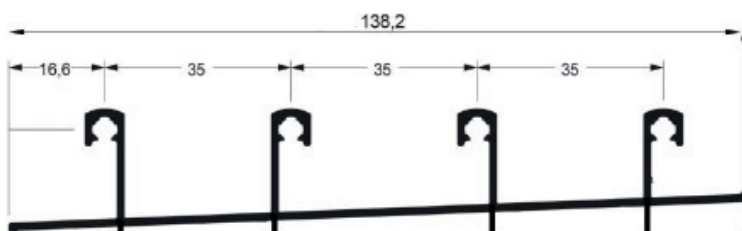

SU040

MONTANTE MÃO DE
AMIGO INTERNO

0,433 Kg/m

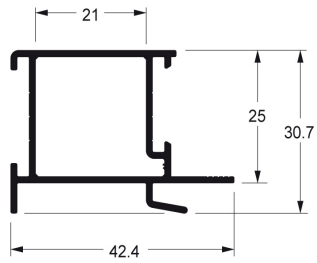

SU041

MONTANTE MÃO DE
AMIGO EXTERNO

0,458 Kg/m

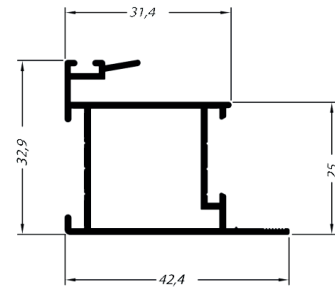

SU042

MONTANTE MÃO DE
AMIGO INTERMEDIÁRIO

0,505 Kg/m

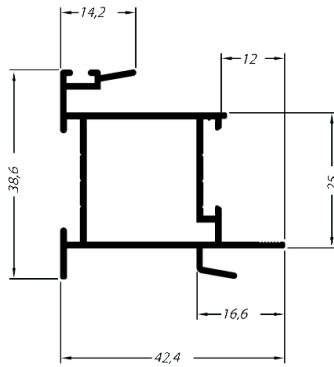

SU053

TRAVESSA SUPERIOR E
INFERIOR

0,480 Kg/m

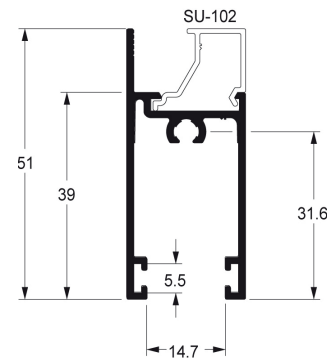

SU039

MONTANTE DA FOLHA

0,472 Kg/m

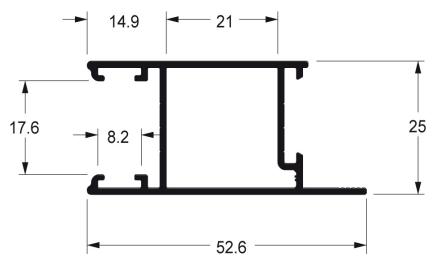

SU245

MONTANTE DE PORTA

0,637 Kg/m

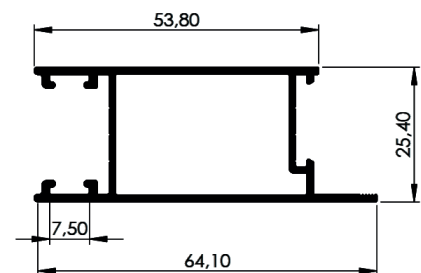

SU242

MONTANTE MÃO DE AMIGO EXTERNO

0,662 Kg/m

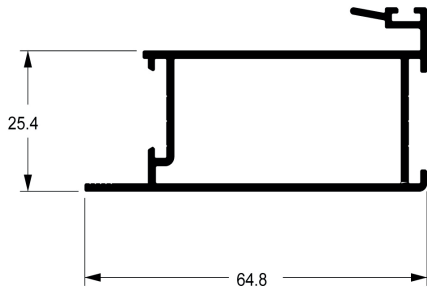

SU243

MONTANTE MÃO DE AMIGO INTERNO

0,633 Kg/m

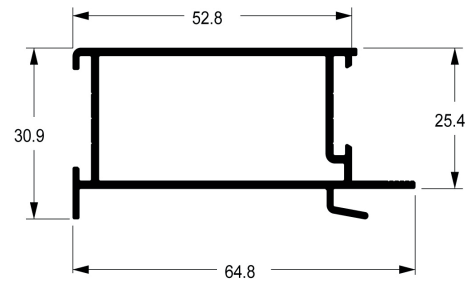

SU108

PORTA PALHETA

0,126 Kg/m

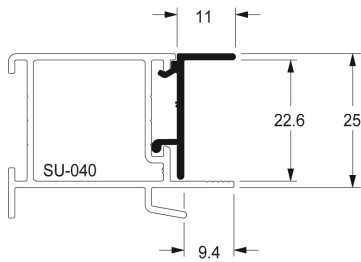

SU227

TRAVESSA CENTRAL

0,609 Kg/m

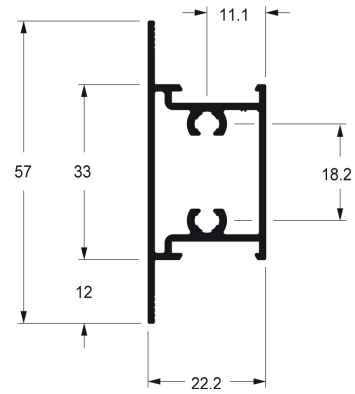

SU049

MONTANTE MÃO DE AMIGO BI-TUBULAR EXTERNO

0,900 Kg/m

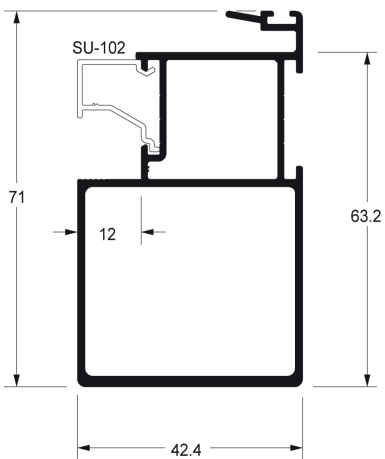

SU047

MONTANTE MÃO DE AMIGO BI-TUBULAR INTERNO

0,900 Kg/m

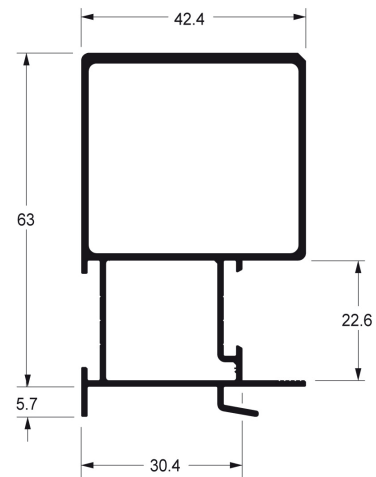

SU192

MONTANTE CENTRAL

0,483 Kg/m

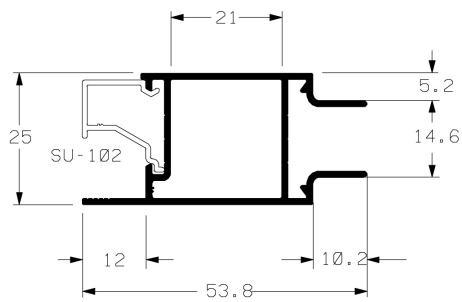

SU281

MONTANTE CENTRAL

1,065 Kg/m

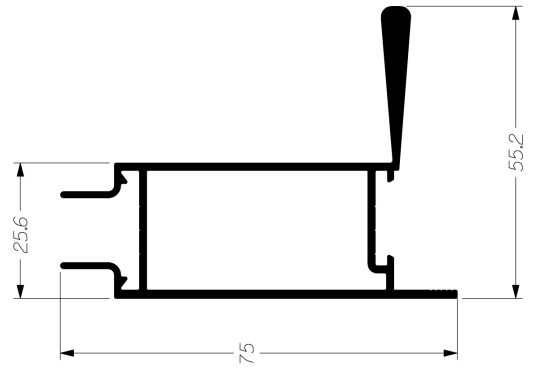

SU280

MONTANTE COM
PUXADOR

0,896 Kg/m

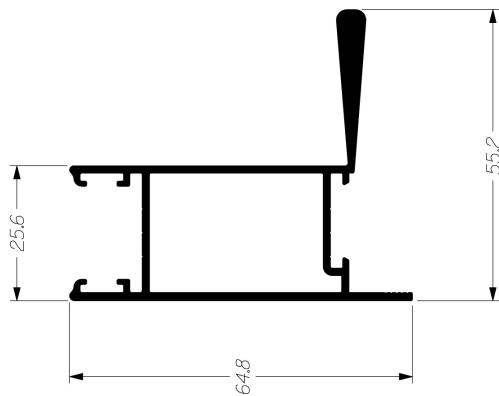

SU225

TRAVESSA INFERIOR DA
FOLHA

0,900 Kg/m

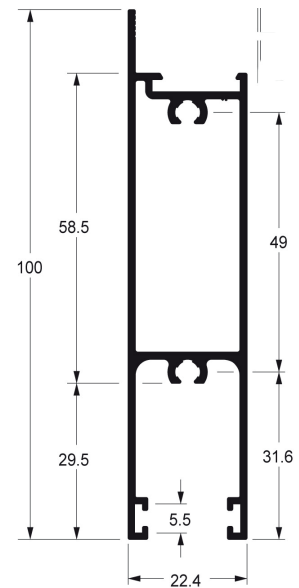

SU153

TRAVESSA SUPERIOR E
INFERIOR REFORÇADA

0,666 Kg/m

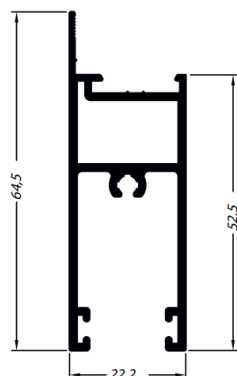

SU271

TRILHO INDIVIDUAL

0,347 Kg/m

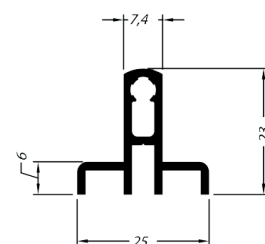

SU008
0,178 Kg/m
COMPLEMENTO MARCO LATERAL

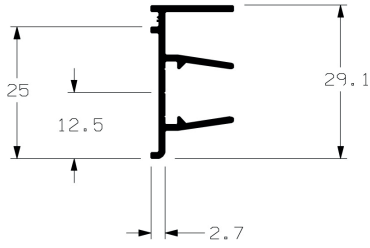

SU291
0,247 Kg/m
COMPLEMENTO CENTRAL

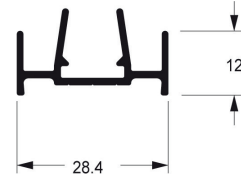

SU102
0,110 Kg/m
BAGUETE

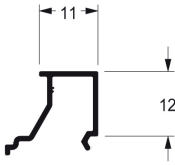

SU103
0,133 Kg/m
BAGUETE

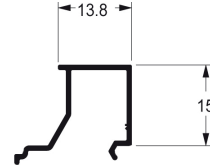

SU186
0,445 Kg/m
TRAVESSA DA FOLHA

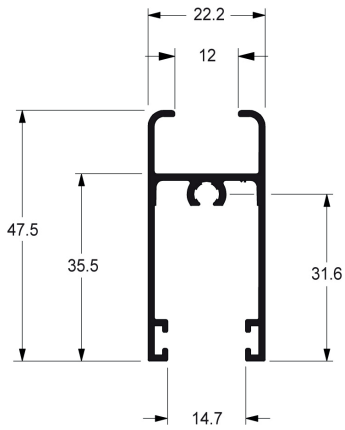

SU187
0,462 Kg/m
TRAVESSA FOLHA VENEZIANA

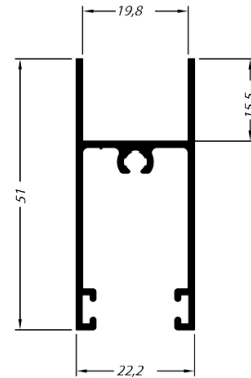

SU055
0,501 Kg/m
MONTANTE SEM BAGUETE

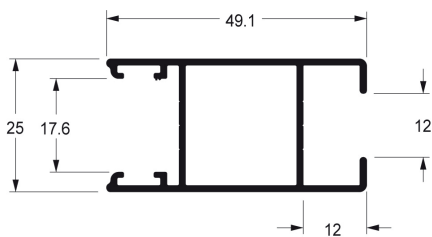

SU068
0,491 Kg/m
MONTANTE DA FOLHA VENEZIANA

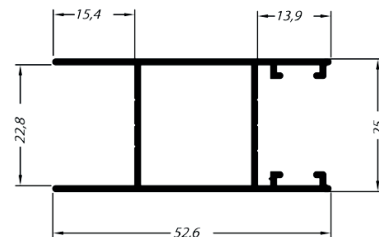

SU190

MONTANTE CENTRAL SEM
BAGUETE

0,546 Kg/m

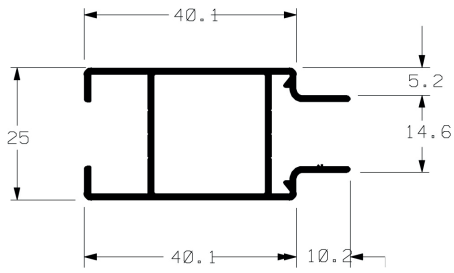

SU191

MONTANTE CENTRAL
VENEZIANA

0,495 Kg/m

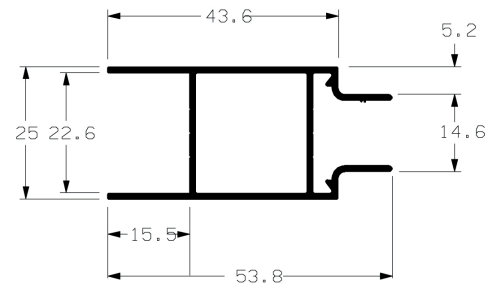

SU069

MONTANTE MÃO DE
AMIGO VENEZIANA

0,518 Kg/m

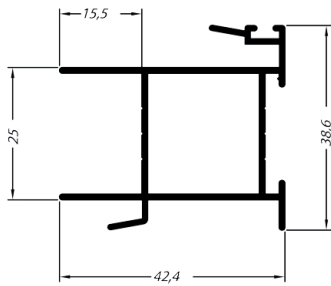

SU070

MONTANTE MÃO DE
AMIGO VENEZIANA

0,471 Kg/m

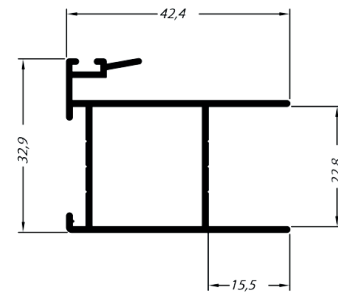

SU056

MONTANTE MÃO DE
AMIGO SEM BAGUETE

0,497 Kg/m

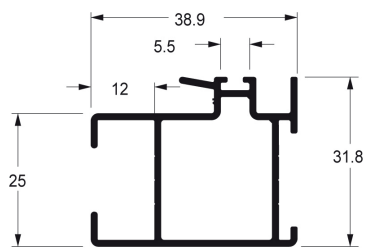

SU057

MONTANTE MÃO DE
AMIGO SEM BAGUETE

0,508 Kg/m

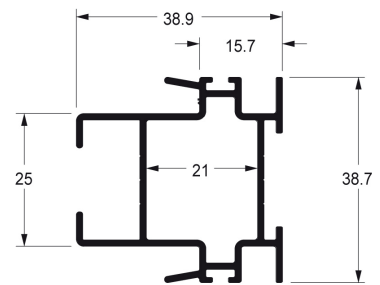

SU060

MONTANTE MÃO DE
AMIGO SEM BAGUETE
BI-TUBULAR

0,974 Kg/m

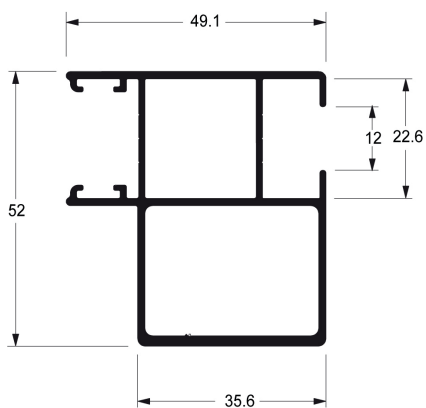

SU061

MONTANTE MÃO DE
AMIGO SEM BAGUETE
BI-TUBULAR

0,972 Kg/m

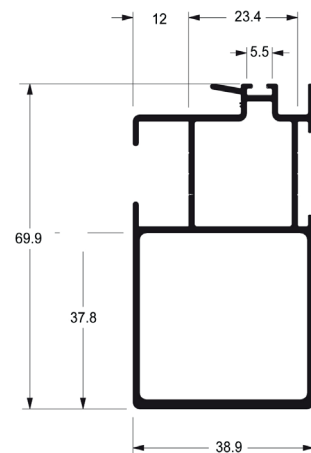

SU238
0,629 Kg/m
MONTANTE SEM BAGUETE

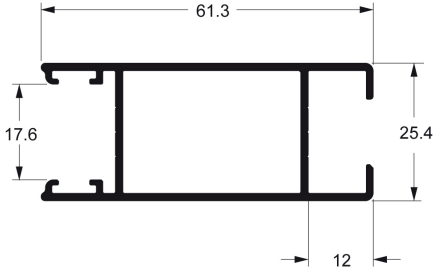

SU239
0,692 Kg/m
MONTANTE MÃO DE AMIGO SEM BAGUETE

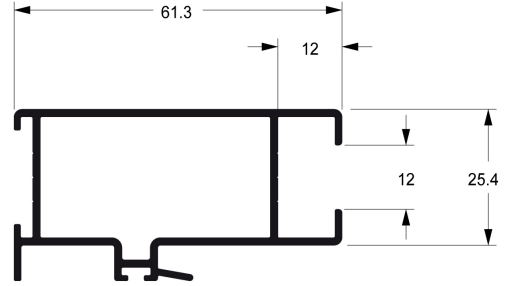

SU226
0,922 Kg/m
TRAVESSA INFERIOR SEM BAGUETE

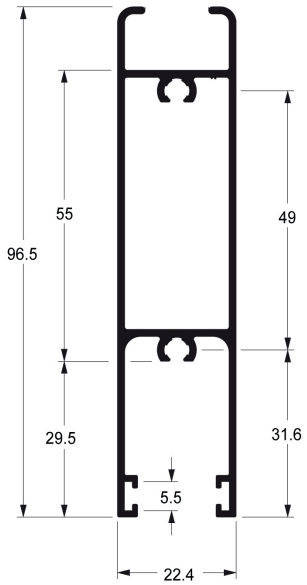

SU188
0,545 Kg/m
TRAVESSA CENTRAL SEM BAGUETE

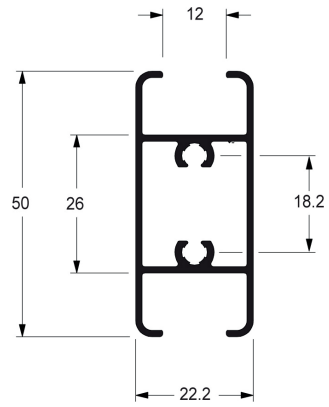

SU292
0,207 Kg/m
INVERSOR DE BAGUETE

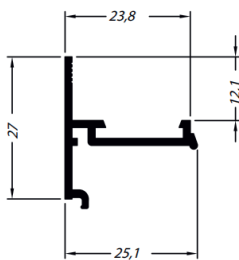

SU107
0,265 Kg/m
VEDAÇÃO DO MONTANTE

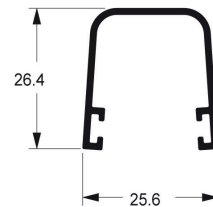

SU285

TRAVESSA HORIZONTAL
SEM BAGUETE

0,282 Kg/m

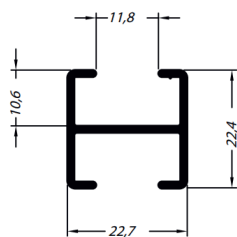

SU284

TRAVESSA VERTICAL SEM
BAGUETE

0,226 Kg/m

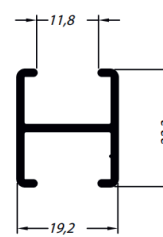

APG043

PORTA PALHETA VZ023

0,163 Kg/m

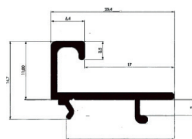

SU120

0,482 Kg/m

MONTANTE DA FOLHA

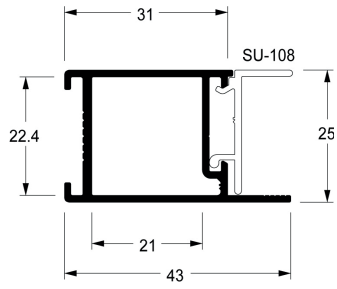

SU112

0,374 Kg/m

MARCO

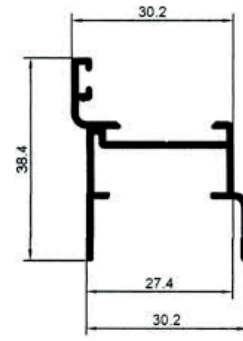

SU071

0,255 Kg/m

MARCO

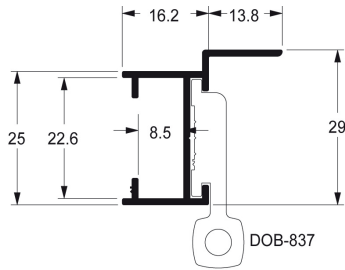

SU072

0,404 Kg/m

MONTANTE DA FOLHA

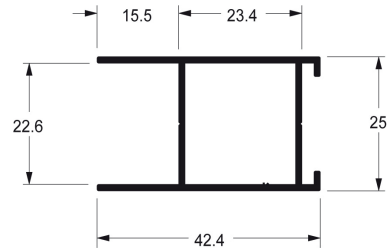

SU073

0,418 Kg/m

TRAVESSA SUPERIOR E INFERIOR

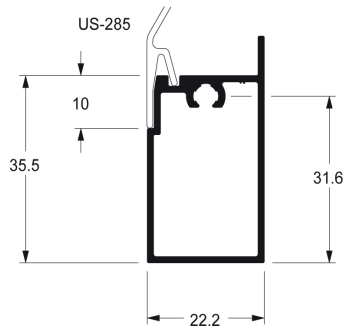

SU074

0,444 Kg/m

MONTANTE CENTRAL DA FOLHA

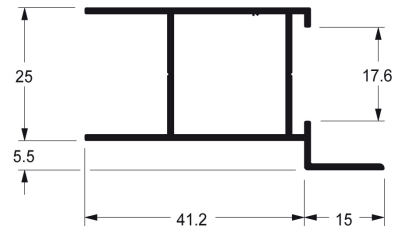

CL050

0,154 Kg/m

GUIA

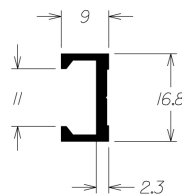

SU024

TRILHO SUPERIOR

0.939 Kg/m

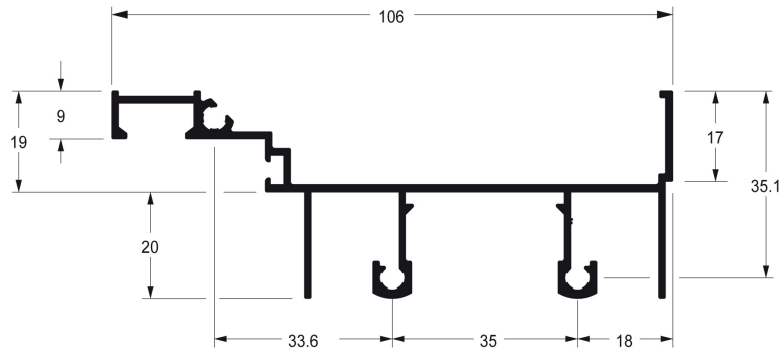

SU025

TRILHO INFERIOR

0.901 Kg/m

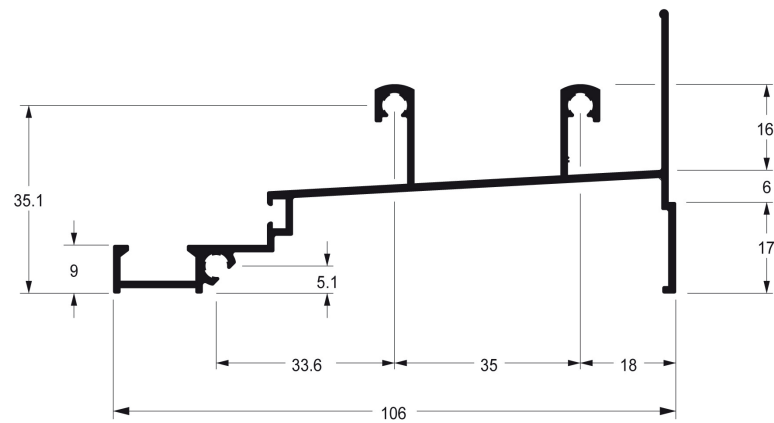

SU079

MARCO MAXIM-AR

0,306 Kg/m

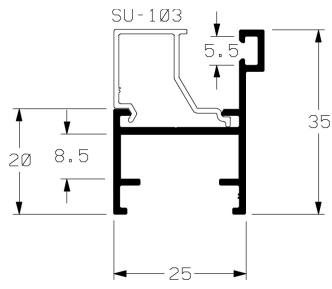

SU081

MONTANTE DA FOLHA
MAXIM-AR

0,359 Kg/m

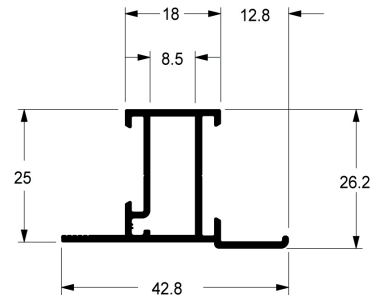

SU082

TRAVESSA DA FOLHA
MAXIM-AR

0,344 Kg/m

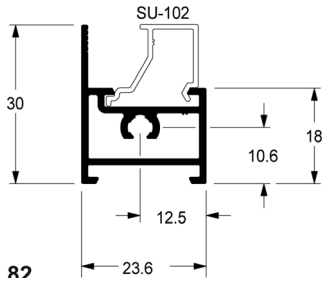

SU083

PINGADEIRA DO MARCO
MAXIM-AR

0,135 Kg/m

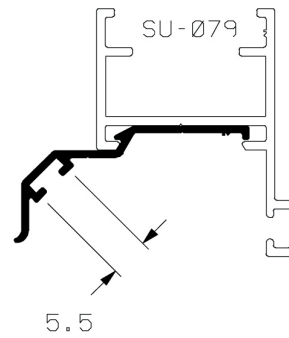

SU080

TRAVESSA SUPERIOR
MAXIM-AR

0,314 Kg/m

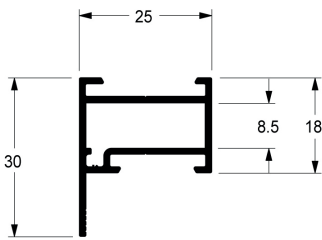

SU203

BAGUETE DA VENEZIANA

0,152 Kg/m

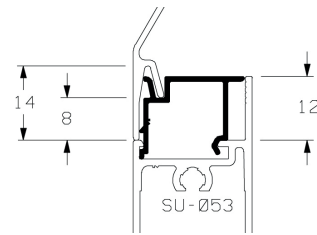

SU200

MONTANTE DA FOLHA
MAXIM-AR

0,384 Kg/m

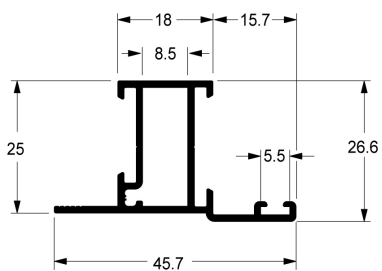

SU086

COLUNA DE MARCO
MAXIM-AR

0,541 Kg/m

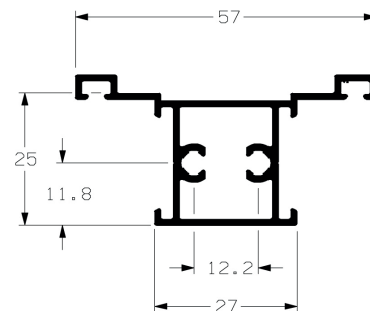

SU088

MARCO DA FOLHA
MAXIM-AR

0,312 Kg/m

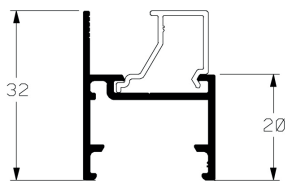

SU090

MONTANTE MAXIM-AR
SEM BAGUETE

0,380 Kg/m

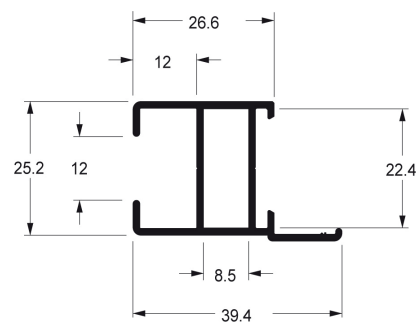

SU091

TRAVESSA SUPERIOR
FOLHA SEM BAGUETE

0,340 Kg/m

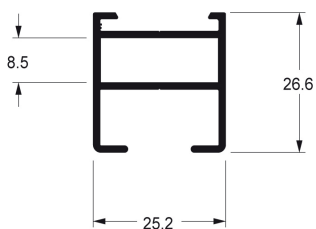

SU084

PINGADEIRA DA FOLHA
MAXIM-AR

0,124 Kg/m

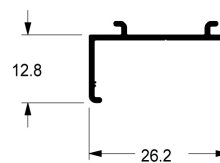

SU093

MARCO

0,285 Kg/m

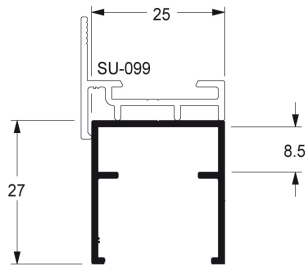

SU094

TRAVESSA DO MARCO

0,377 Kg/m

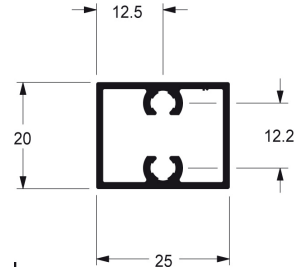

SU095

MONTANTE DO MARCO

0,189 Kg/m

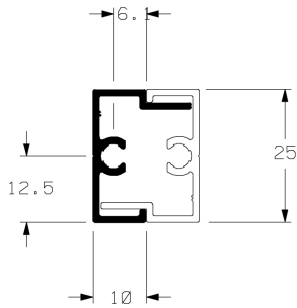

SU096

MONTANTE DA FOLHA SUPERIOR

0,271 Kg/m

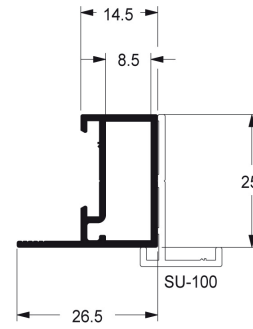

SU097

TRAVESSA DA FOLHA

0,367 Kg/m

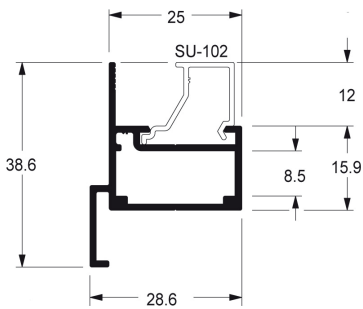

SU098

TRAVESSA DA FOLHA

0,367 Kg/m

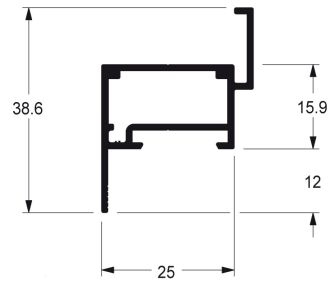

SU099

COMPONENTE FIXO

0,209 Kg/m

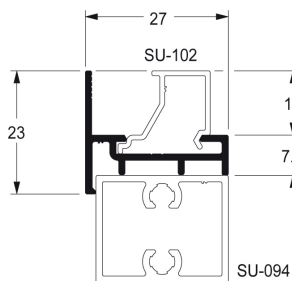

SU100

MATA JUNTA

0,155 Kg/m

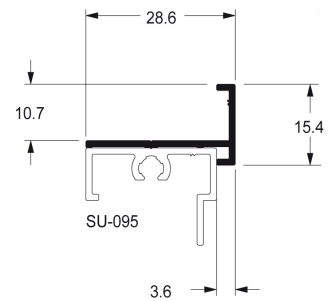

20142

SUPOORTE

0,311 Kg/m

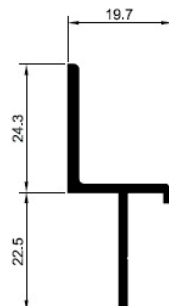

ALG044

TRILHO SUPERIOR 2
PLANOS

1,065 Kg/m

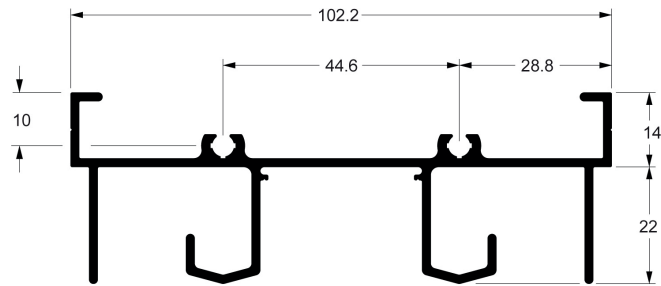

ALG004

TRAVESSA INTERMEDIÁRIA
BANDEIRA

1,774 Kg/m

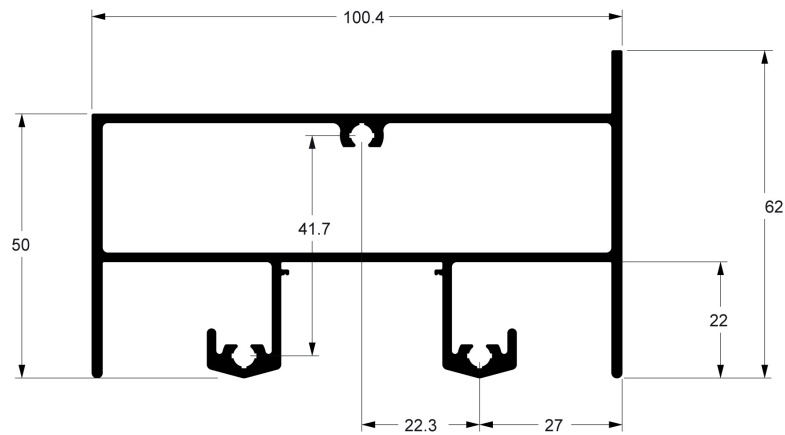

ALG024

TRILHO INFERIOR JANELA
2 PLANOS

1,031 Kg/m

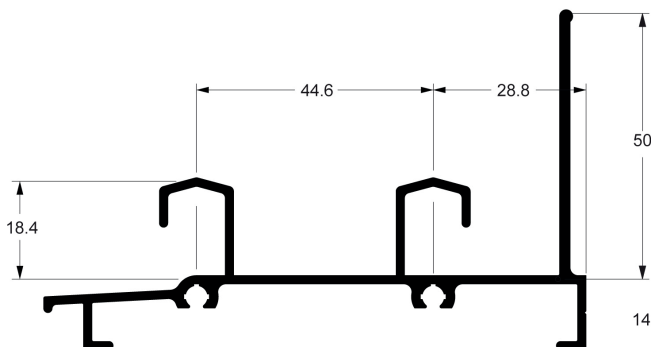

ALG115

TRILHO INFERIOR JANELA
2 PLANOS

1,296 Kg/m

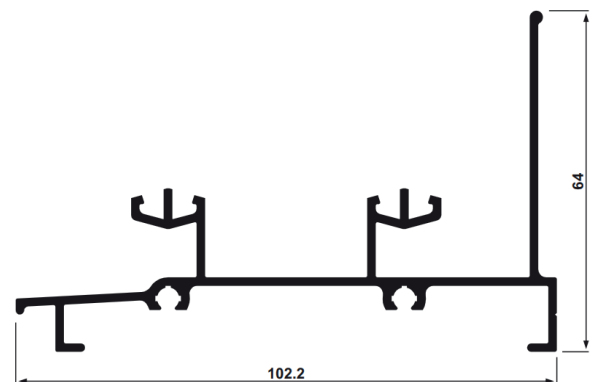

ITEM SOB CONSULTA

ALG047

TRILHO INFERIOR PORTA
2 PLANOS

0,697 Kg/m

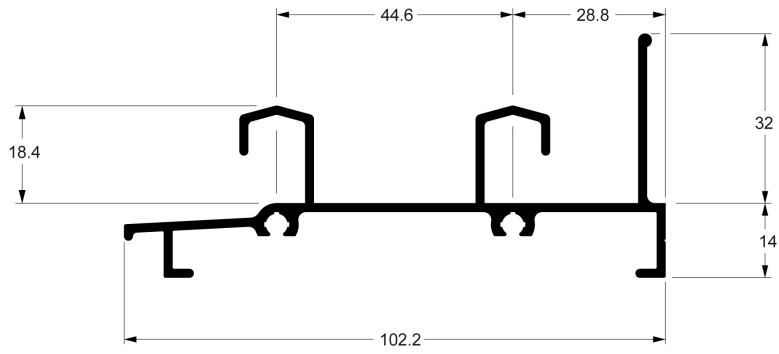

ALG159

TRILHO INFERIOR PORTA
2 PLANOS

1,139 Kg/m

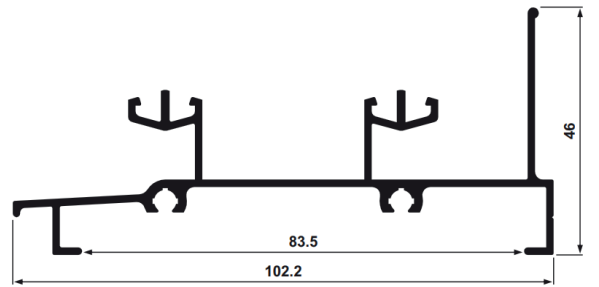

ITEM SOB CONSULTA

ALG005

TRAVESSA PEITORIL FIXO

1,989 Kg/m

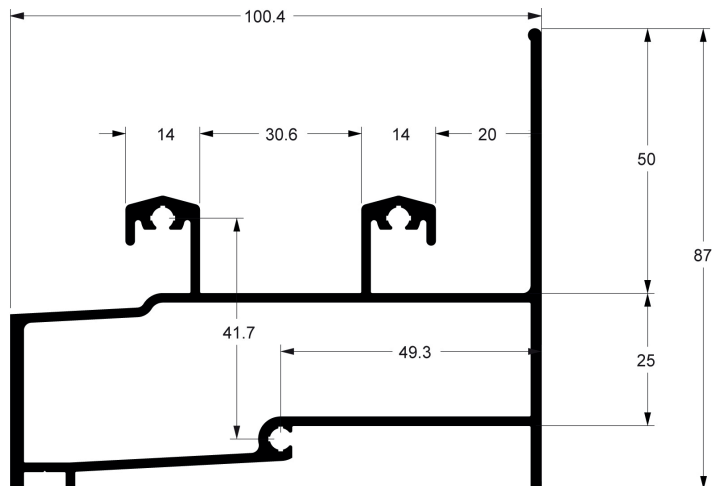

ALG002

MARCO LATERAL 2
PLANOS

0,536 Kg/m

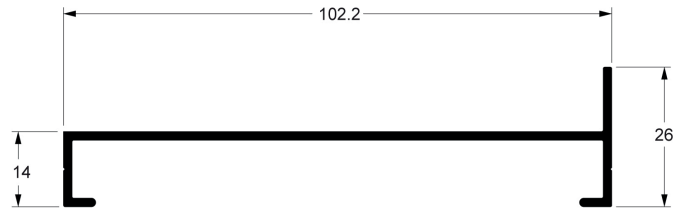

ALG003

TRAVESSA SUPERIOR

0,679 Kg/m

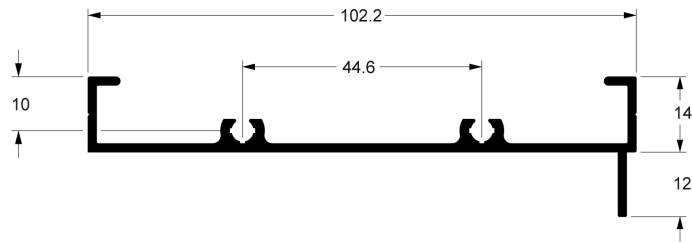

ALG124

MARCO LATERAL 2
PLANOS

0,714 Kg/m

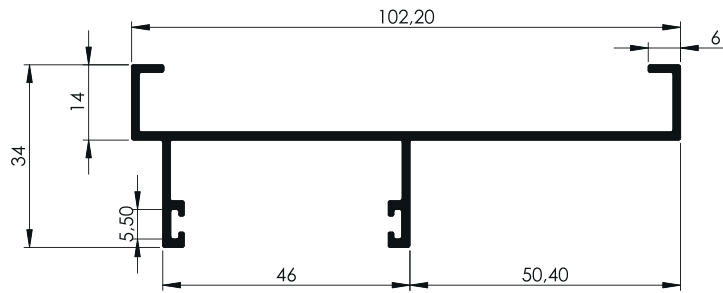

ALG045

MARCO LATERAL 2
PLANOS

0,898 Kg/m

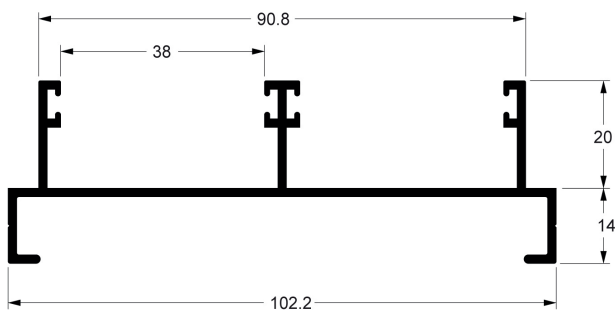

ALG028

COMPLEMENTO LATERAL

0,375 Kg/m

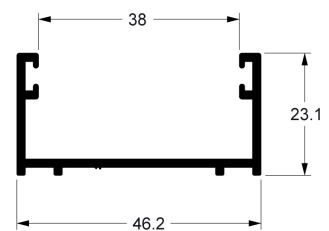

ALG100

MATA JUNTA CENTRAL

0,282 Kg/m

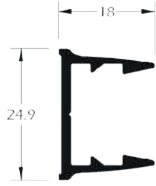

ALG046

TAMPA MARCO LATERAL

0,204 Kg/m

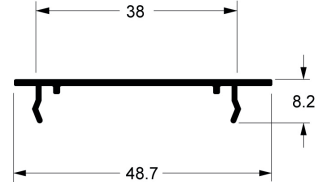

PC007

TRILHO INFERIOR DE EMBUTIR

0,172 Kg/m

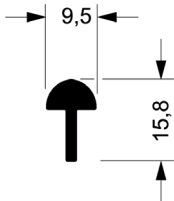

ALG061

TRILHO INDIVIDUAL

0,318 Kg/m

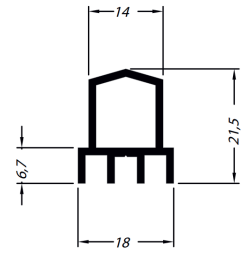

ALG022

TRAVESSA

1,064 Kg/m

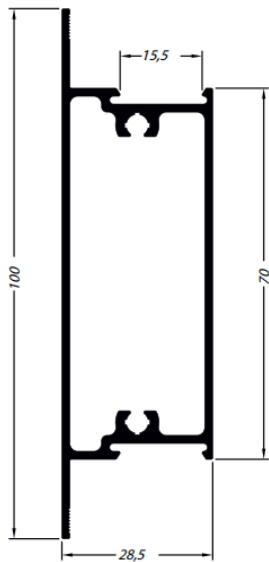

ALG058

PERFIL PORTA DE GIRO

0,759 Kg/m

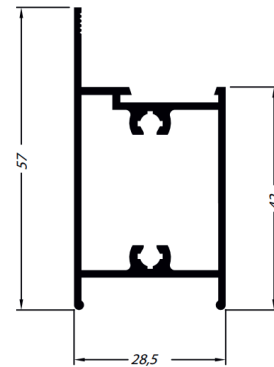

ALG062

TRILHO SUPERIOR 3
PLANOS

1,590 Kg/m

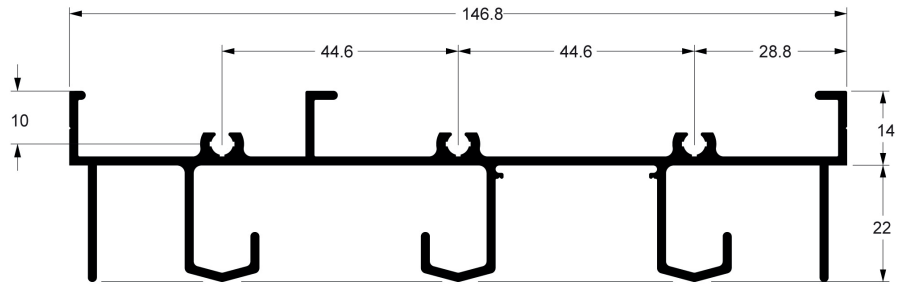

ALG066

TRILHO INFERIOR 3
PLANOS

1,417 Kg/m

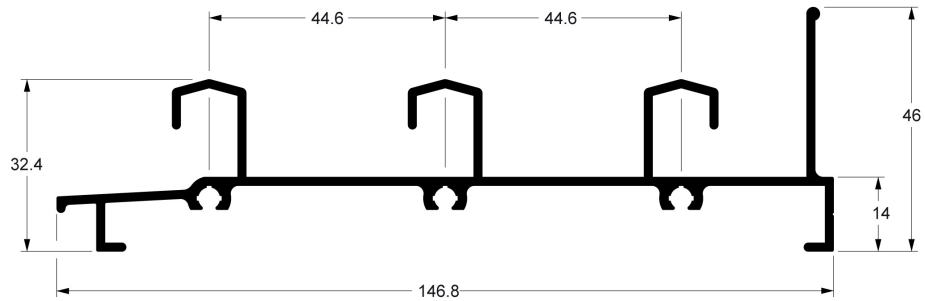

ALG116

TRILHO INFERIOR 3
PLANOS

1,533 Kg/m

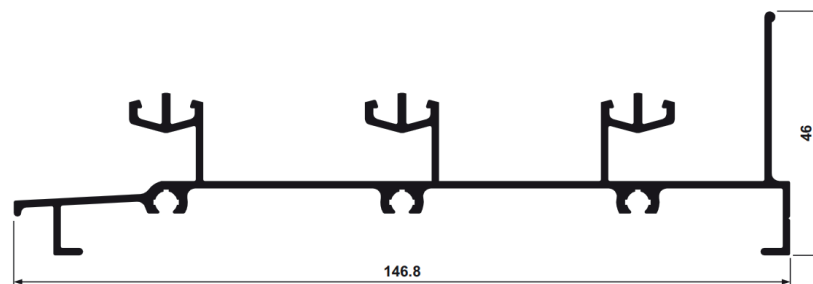

ITEM SOB CONSULTA

ALG064

MARCO LATERAL 3
PLANOS

1,250 Kg/m

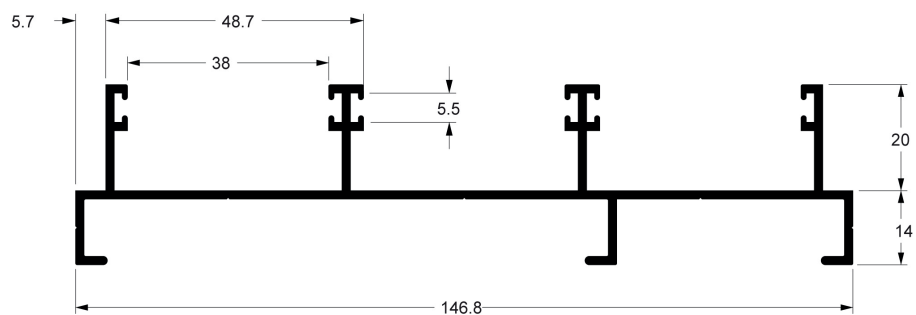

ALG070

TRILHO SUPERIOR 4
PLANOS

2,075 Kg/m

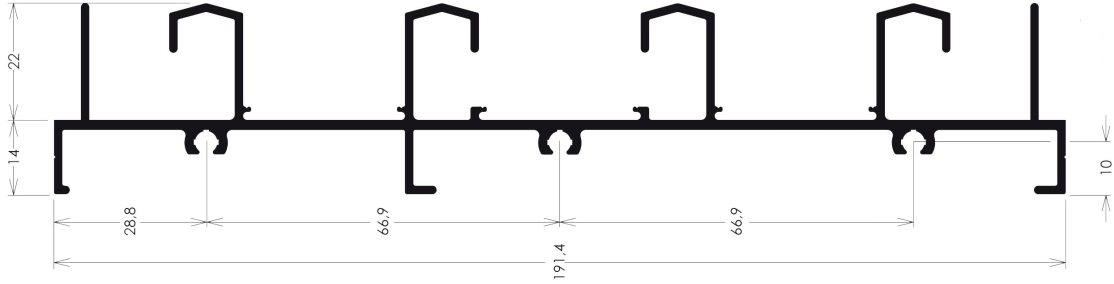

ALG160

TRILHO INFERIOR 4
PLANOS

2,085 Kg/m

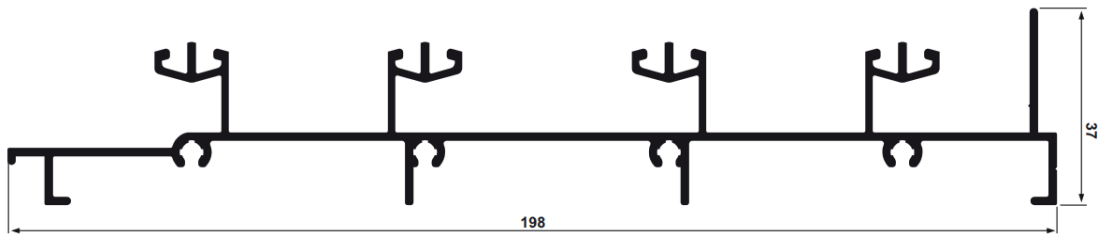

ITEM SOB CONSULTA

ALG071

TRILHO INFERIOR 4
PLANOS

1,962 Kg/m

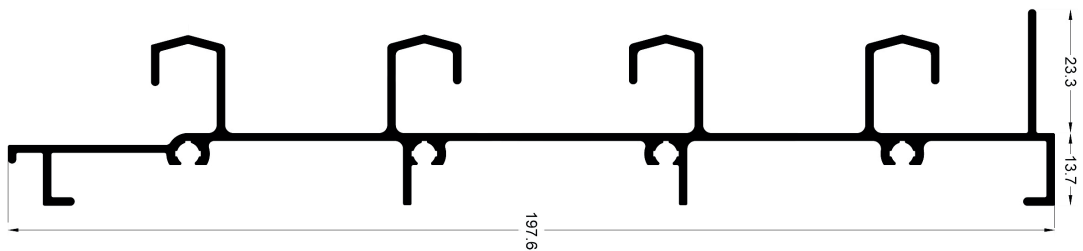

ALG158

MARCO LATERAL 3
PLANOS

0,887 Kg/m

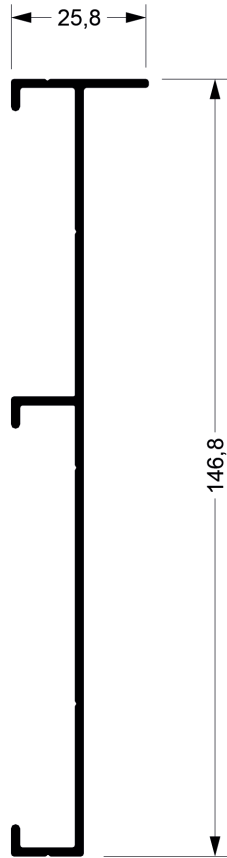

ALG072

MARCO LATERAL 4
PLANOS

1,962 Kg/m

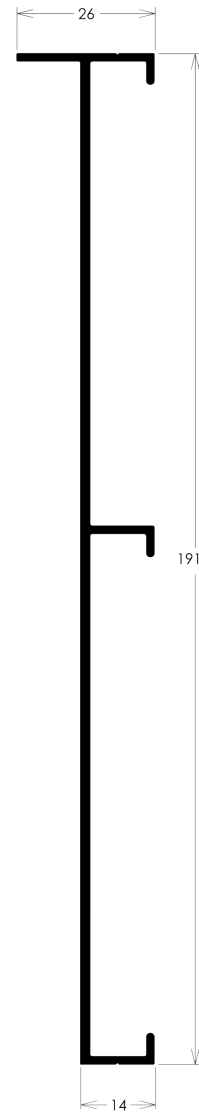

ALG049

MONTANTE MÃO DE
AMIGO

0,815 Kg/m

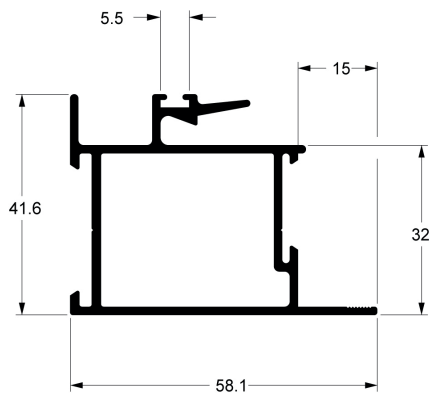

ALG048

MONTANTE MÃO DE
AMIGO

0,802 Kg/m

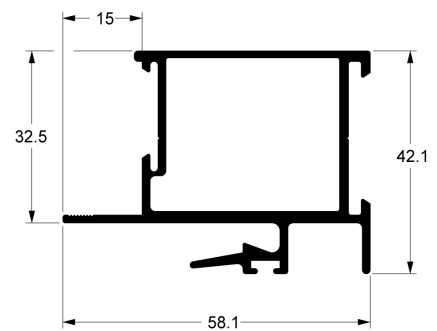

ALG050

MONTANTE DA FOLHA

0,737 Kg/m

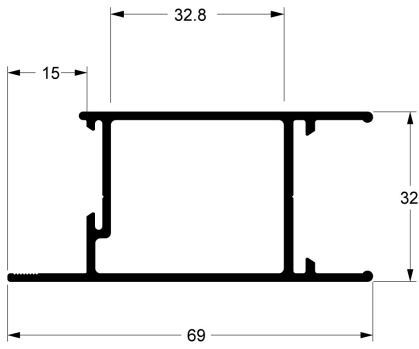

ALG051

MONTANTE CENTRAL

0,830 Kg/m

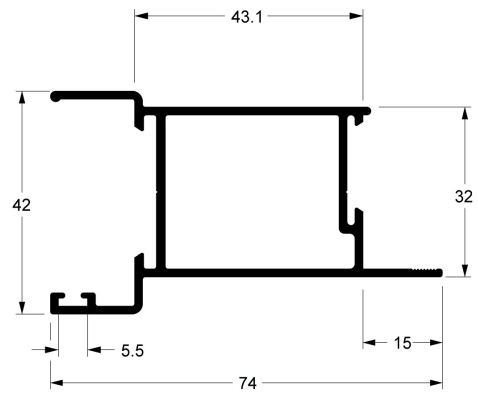

ALG017

MONTANTE CENTRAL

0,978 Kg/m

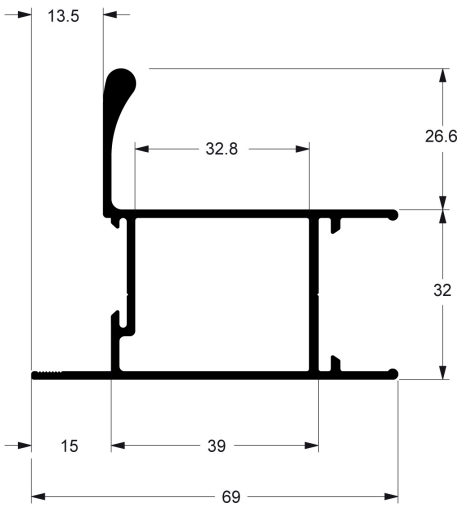

ALG020

MONTANTE CENTRAL

1,075 Kg/m

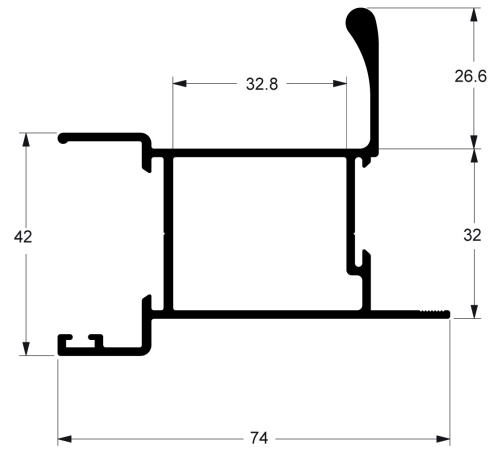

ALG007

TRAVESSA INFERIOR DA FOLHA

1,149 Kg/m

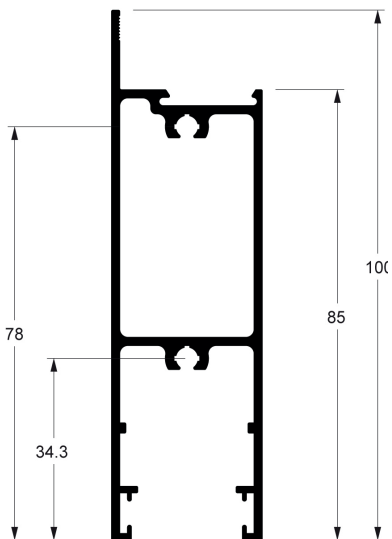

ALG118

TRAVESSA INFERIOR DA FOLHA

1,285 Kg/m

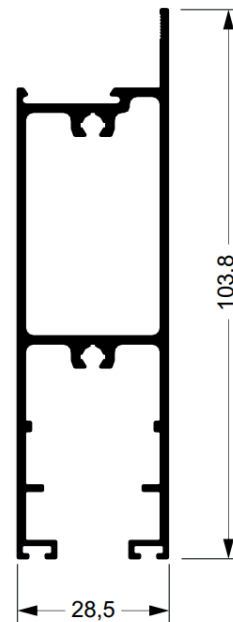

ALG022

TRAVESSA CENTRAL
100MM

1,022 Kg/m

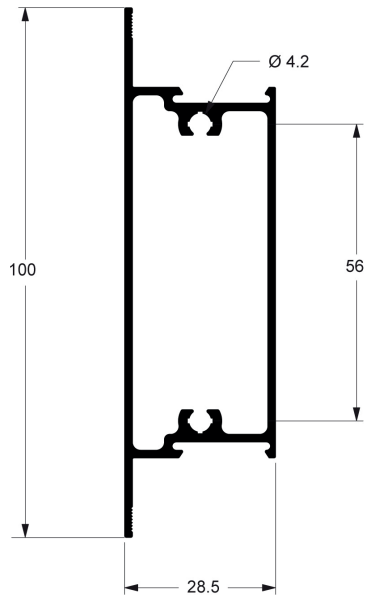

ALG021

MONTANTE BI-TUBULAR
INTERNO

1,549 Kg/m

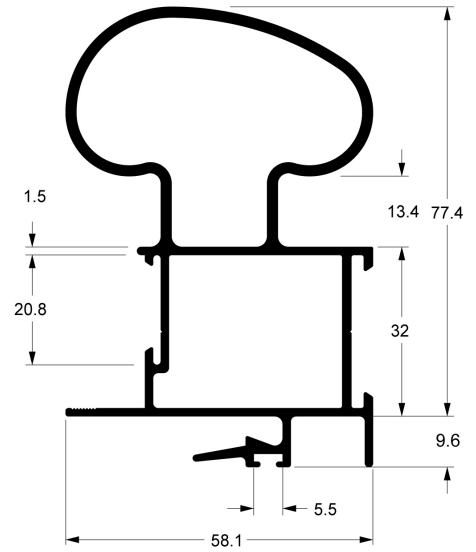

ALG055

TRAVESSA CENTRAL

0,759 Kg/m

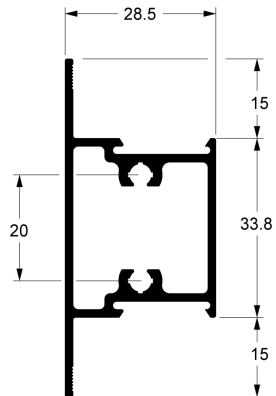

ALG023

MONTANTE BI-TUBULAR
EXTERNO

1,549 Kg/m

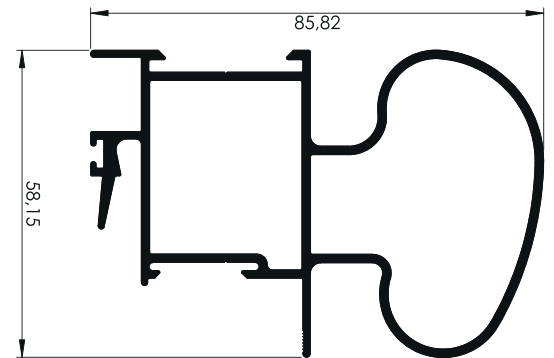

ALG054

MONTANTE BI-TUBULAR
EXTERNO

1,575 Kg/m

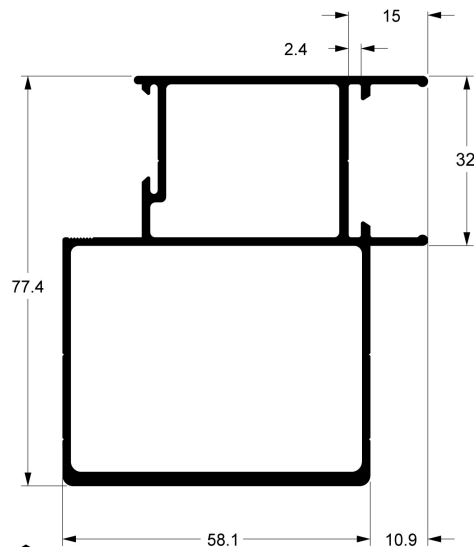

ALG052

MONTANTE BI-TUBULAR
INTERNO

1,669 Kg/m

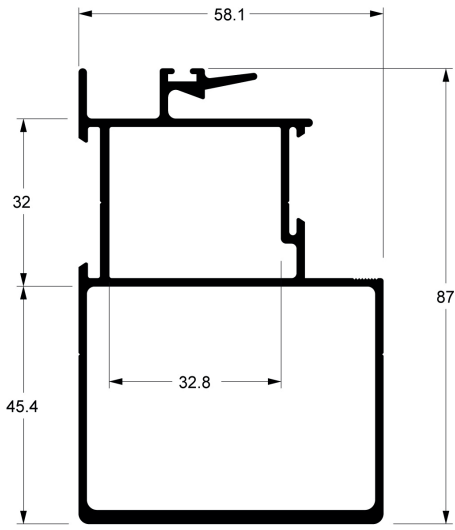

ALG093

MONTANTE BI-TUBULAR
INTERNO

1,331 Kg/m

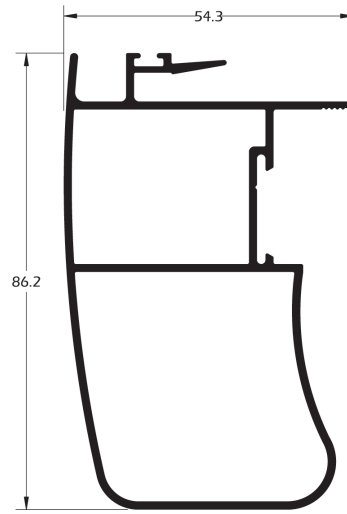

ALG093A

MONTANTE MÃO AMIGO

1,185 Kg/m

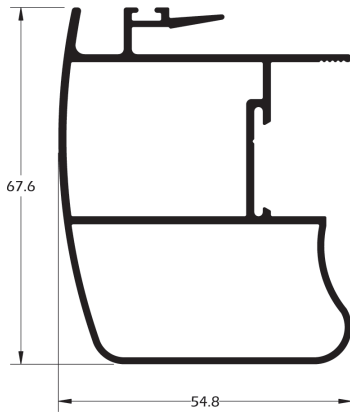

ALG094

MONTANTE BI-TUBULAR
EXTERNO

1,331 Kg/m

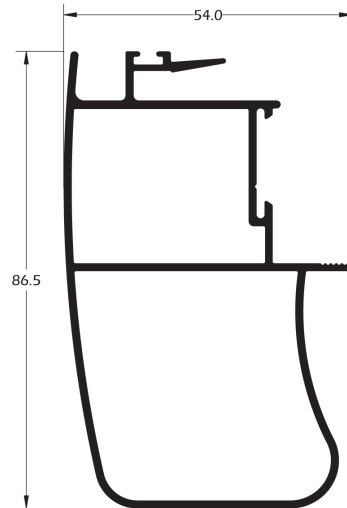

ALG173

MONTANTE CENTRAL

1,191 Kg/m

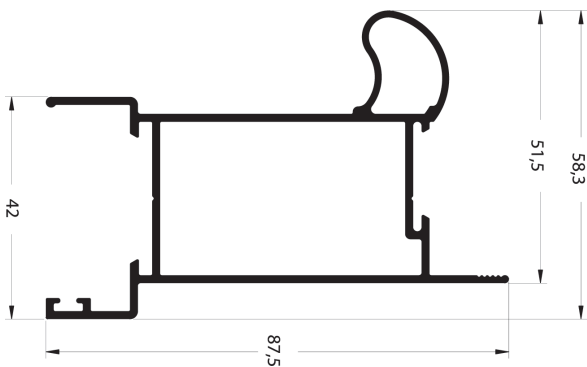

ALG174

MONTANTE CENTRAL

1,084 Kg/m

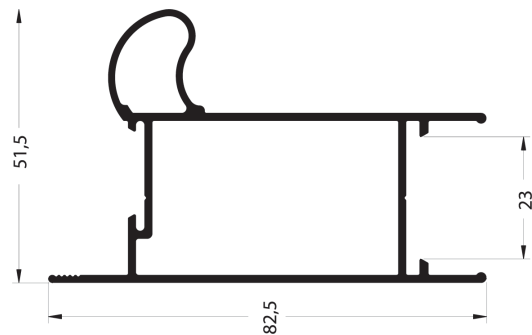

ALG162

1,051 Kg/m

MONTANTE INTERMEDIÁRIO

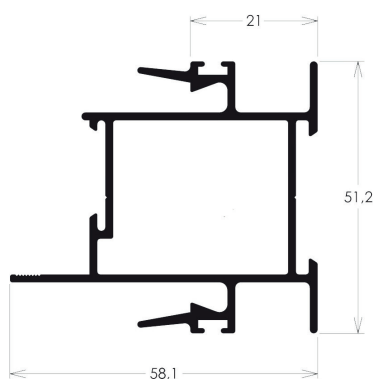

ALG178

0,958 Kg/m

MONTANTE INTERMEDIÁRIO

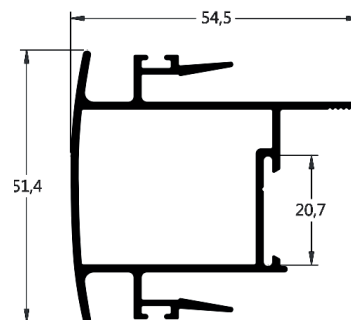

ALG091

0,808 Kg/m

MONTANTE MÃO DE AMIGO

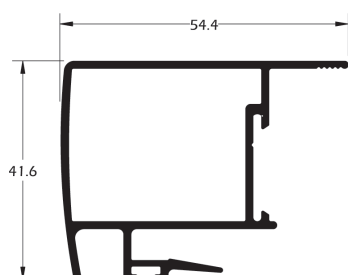

ALG111

0,815 Kg/m

MONTANTE MÃO DE AMIGO

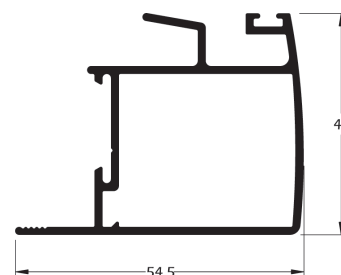

ALG090

0,806 Kg/m

MONTANTE MÃO DE AMIGO

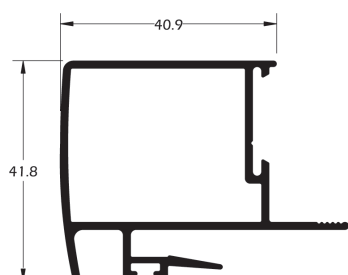

ALG088

0,825 Kg/m

MONTANTE CENTRAL

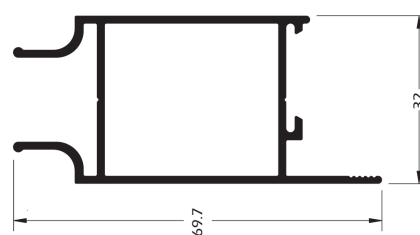

ALG087

0,843 Kg/m

MONTANTE DA FOLHA

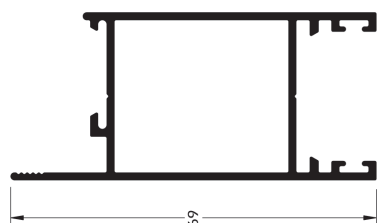

ALG006

0,677 Kg/m

TRAVESSA SUPERIOR E INFERIOR

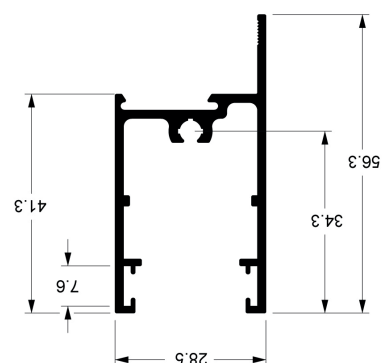

ALG079

COMPLEMENTO DO MONTANTE

0,551 Kg/m

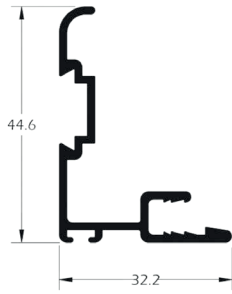

ALG176

TRAVESSA DO QUADRO FIXO

1,420 Kg/m

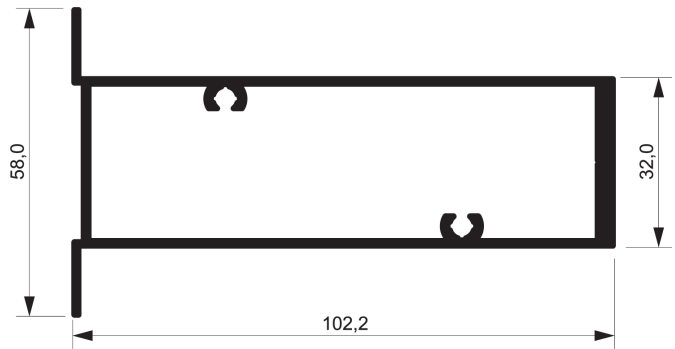

ALG026

BAGUETE VERTICAL 13MM

0,156 Kg/m

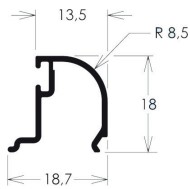

ALG059

BAGUETE 17MM

0,169 Kg/m

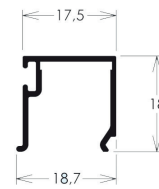

ALG027

PORTA PALHETA

0,141 Kg/m

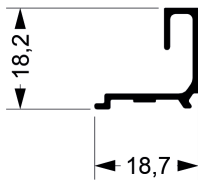

ALG015

BAGUETE DE VIDRO DUPLO

0,144 Kg/m

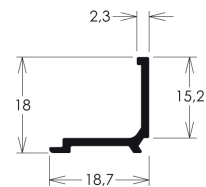

ALG164

BAQUETE VERTICAL 17MM

0,160 Kg/m

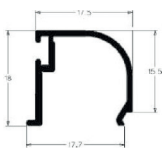

ALG112

CLICK PARA O TRILHO INFERIOR

0,089 Kg/m

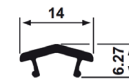

ITEM SOB CONSULTA

ALG057

BAGUETE 13MM

0,167 Kg/m

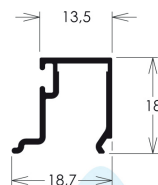

ALG092

PINGADEIRA

0,145 Kg/m

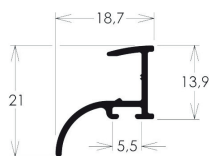

ALG085

MONTANTE DA FOLHA

0,452 Kg/m

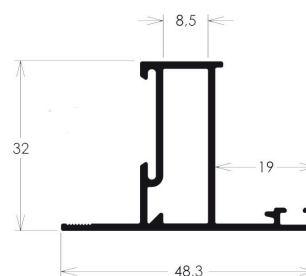

ALG174

TRAVESSA INTERMEDIÁRIA

0,721 Kg/m

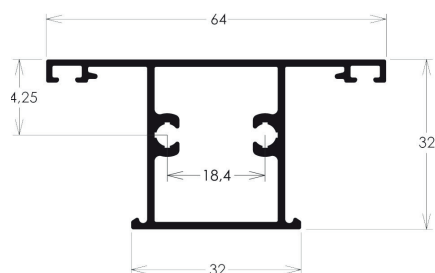

ALG068

MARCO

0,369 Kg/m

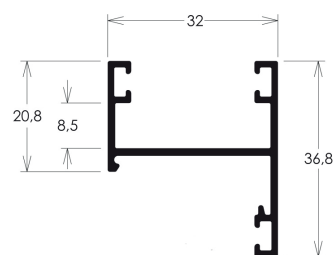

ALG063

PERFIL QUADRO FIXO

0,428 Kg/m

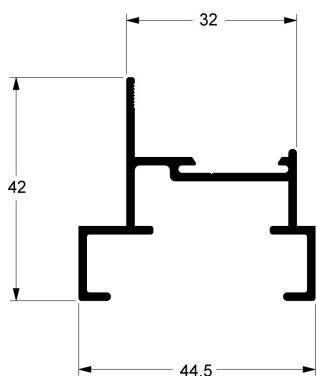

ALG083

MONTANTE QUADRO FIXO

0,368 Kg/m

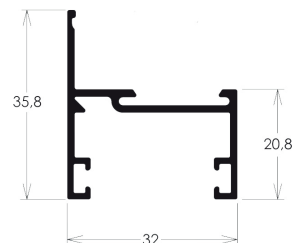

ALG076

TRAVESSA COM INVERSOR

0,679 Kg/m

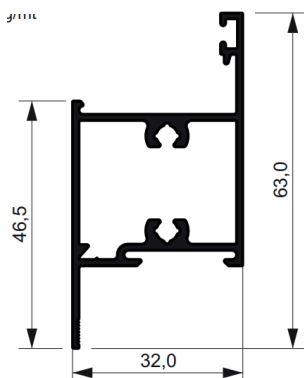

ALG077

PERFIL DE INVERSÃO

0,300 Kg/m

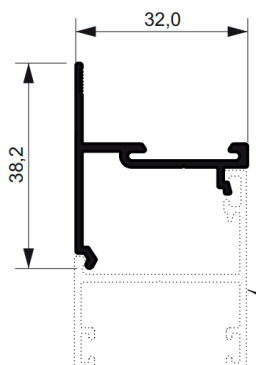

ALG180

MONTANTE

0,417 Kg/m

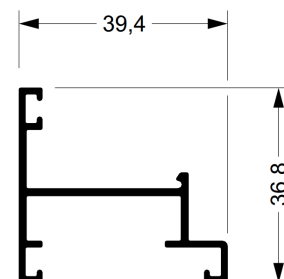

MN001

MARCO SUPERIOR 2
PLANOS

1,274 Kg/m

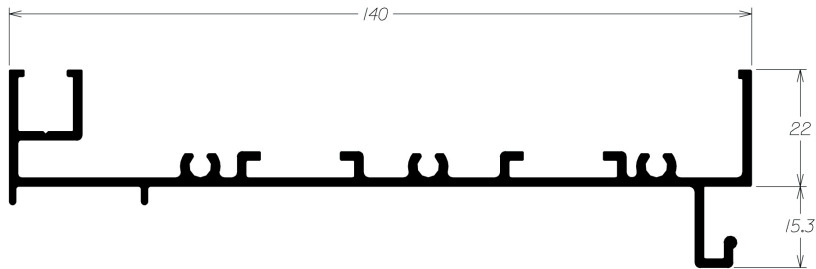

MN002

MARCO INTERMEDIÁRIO

0,570 Kg/m

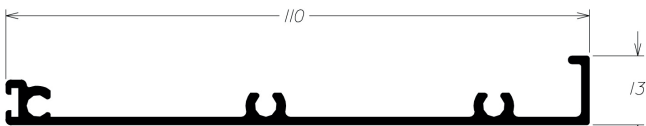

ALG166

TRILHO SUPERIOR 2
PLANOS

1,745 Kg/m

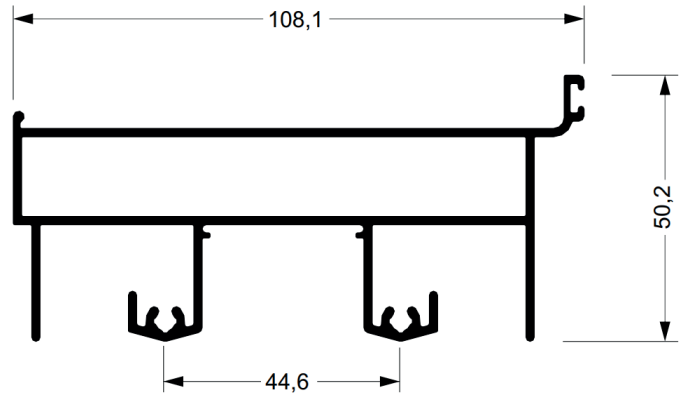

MN003

MARCO LATERAL 3
PLANOS

0,990 Kg/m

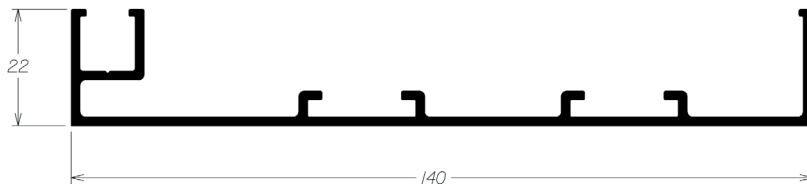

MN030

TRILHO INFERIOR 2
PLANOS

1,515 Kg/m

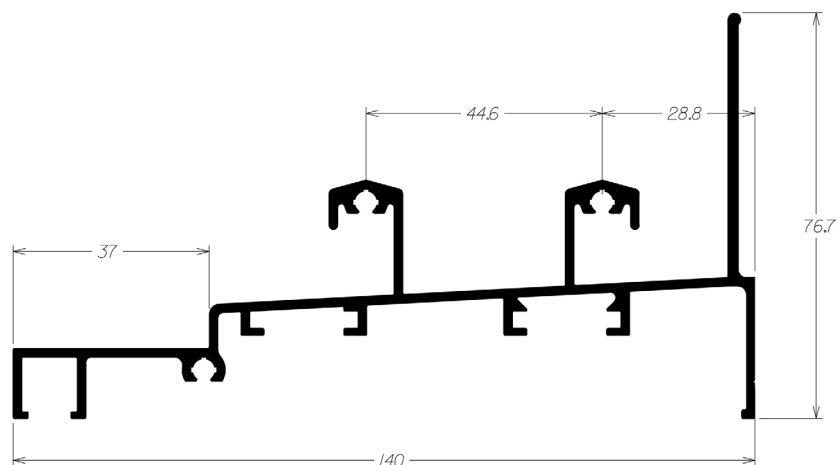

ALG041

MARCO SUPERIOR 3
PLANOS

1,271 Kg/m

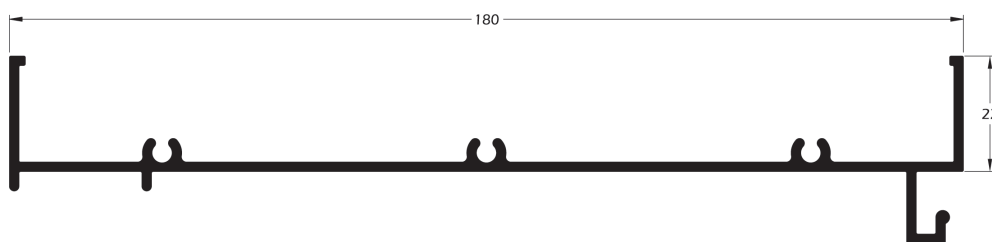

ALG034

TRILHO SUPERIOR 3
PLANOS

2,142 Kg/m

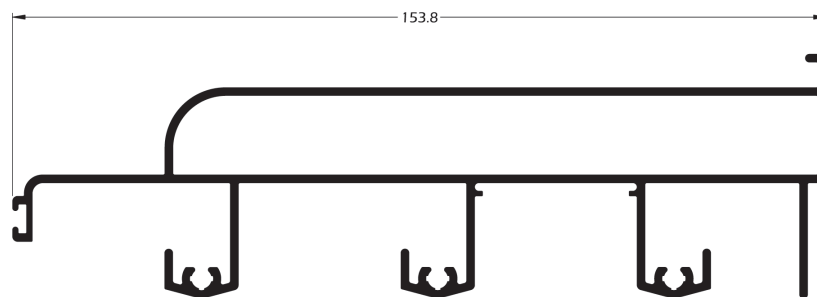

MN061

TRILHO INFERIOR 2
PLANOS PORTA

1,332 Kg/m

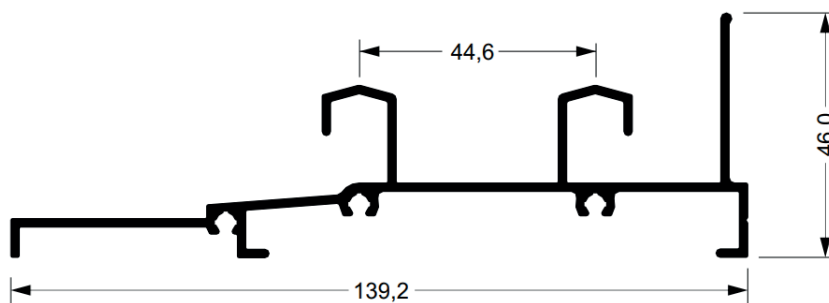

MN009

TAMPA EXTERNA JANELA

0,753 Kg/m

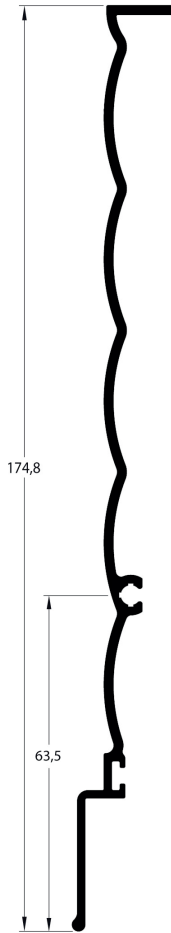

MN031

TAMPA INTERNA JANELA

1,217 Kg/m

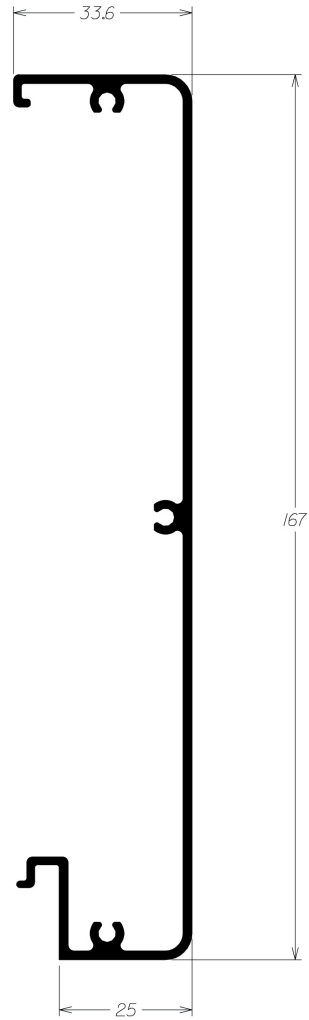

ALG035

MARCO LATERAL 3
PLANOS

1,085 Kg/m

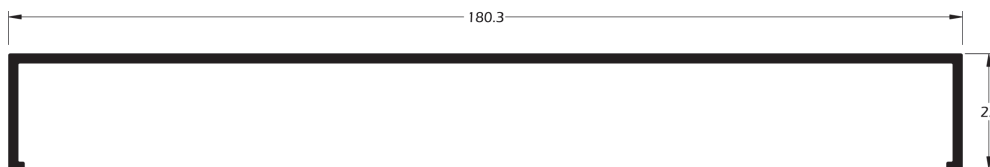

MN039

1,240 Kg/m

TAMPA EXTERNA PORTA

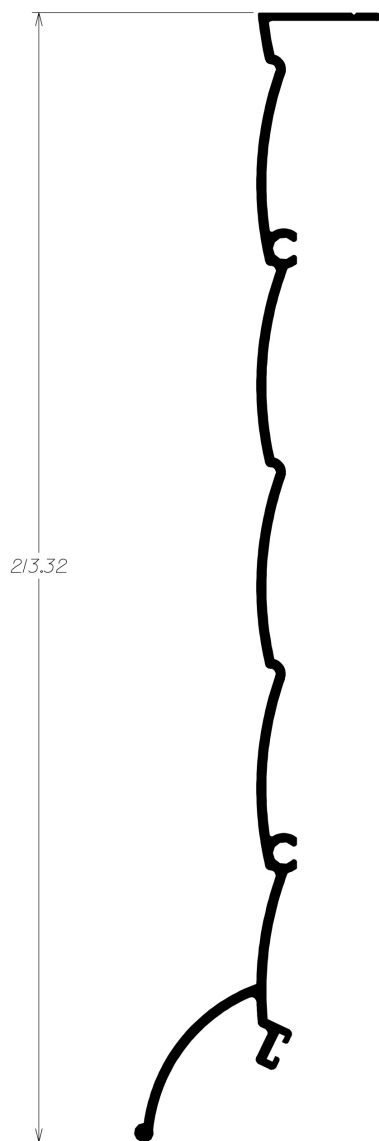

MN032

1,573 Kg/m

TAMPA INTERNA PORTA

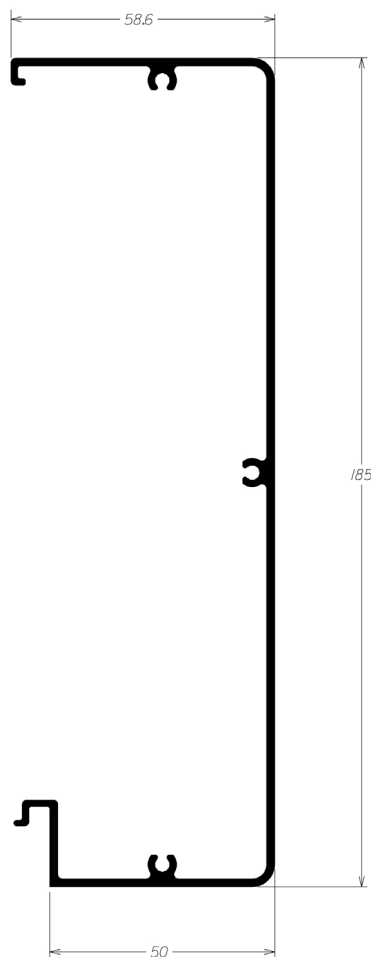

MN050

0,737 Kg/m

LATERAL DA CAIXA

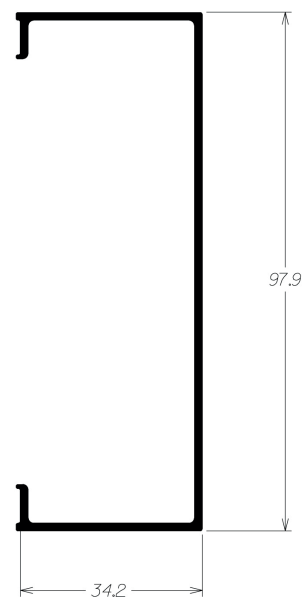

MN007

0,640 Kg/m

GUIA DA PERSIANA

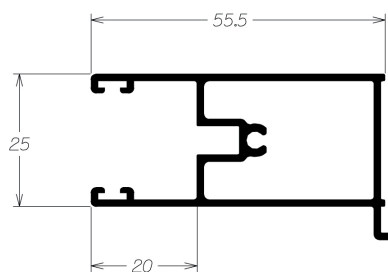

MN027

0,977 Kg/m

COLUNA CENTRAL

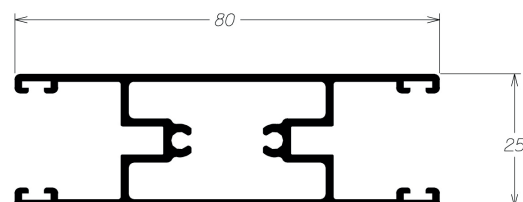

FC233

COLUNA REFORÇADA

3,449 Kg/m

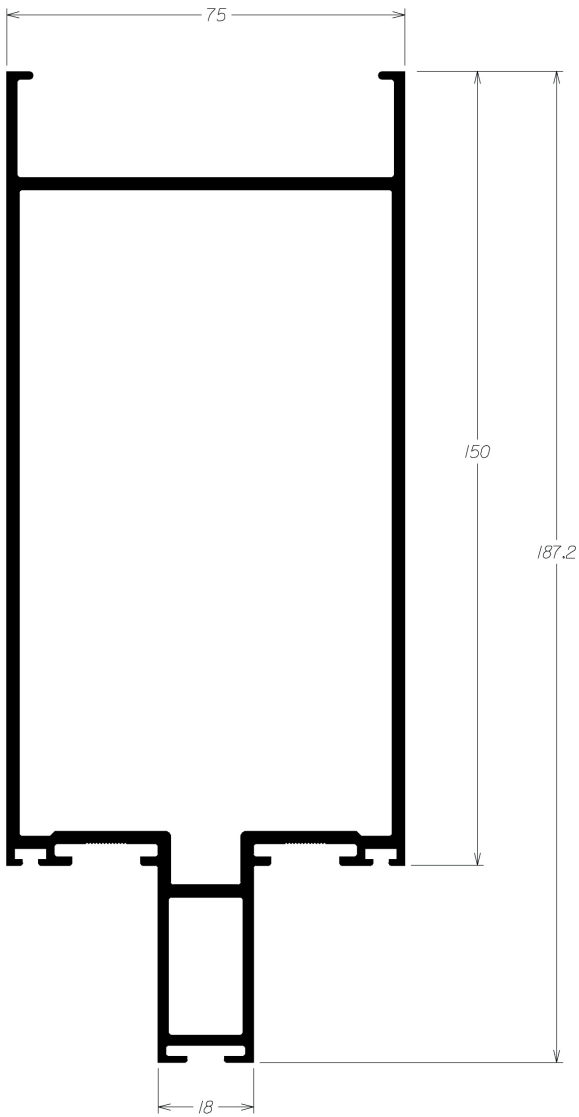

FC202

COLUNA

1,608 Kg/m

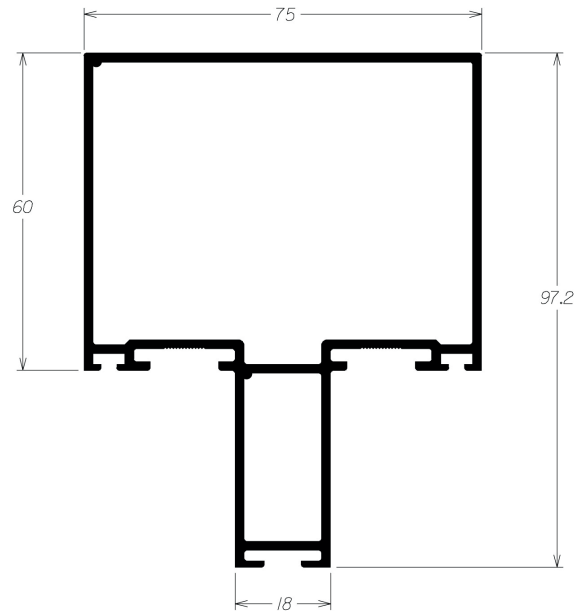

FC225

MARCO VERTICAL-HORIZONTAL

0,591 Kg/m

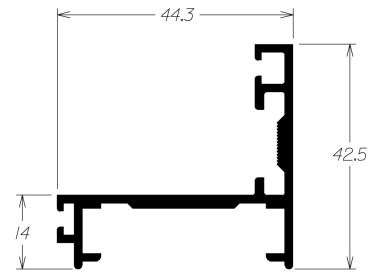

FC243

MARCO LATERAL

0,974 Kg/m

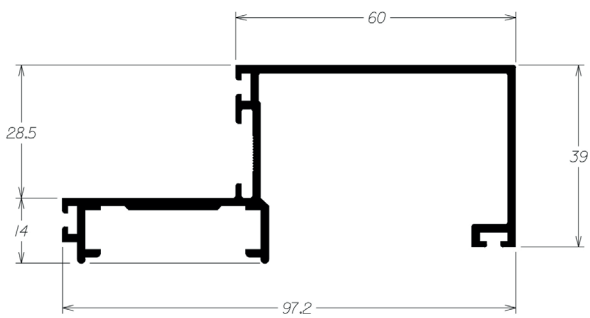

FC244

COLUNA DE CANTO 90°

1,728 Kg/m

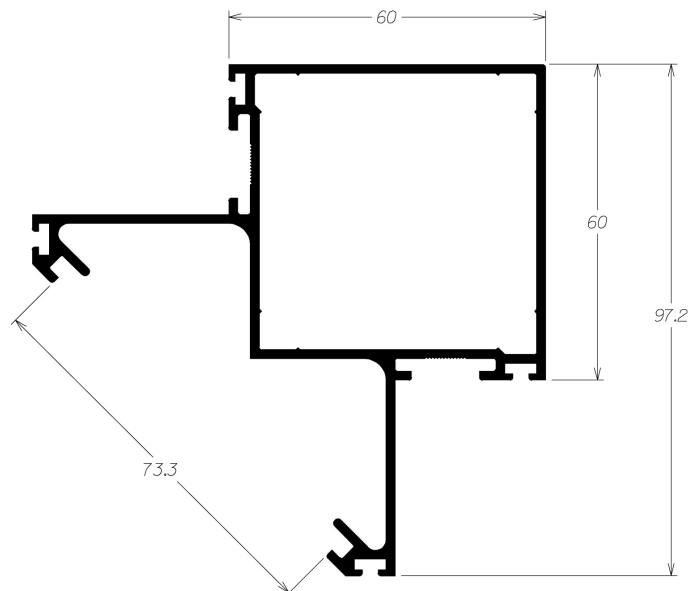

FC231

COLUNA SIMPLES

0,987 Kg/m

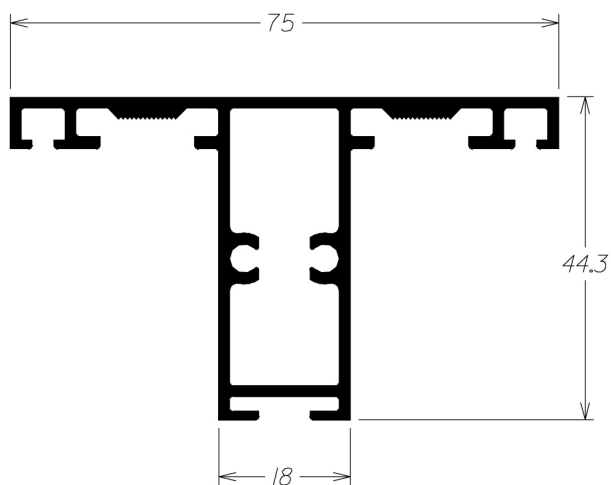

FC227

PINGADEIRA QUADRO
MÓVEL

0,634 Kg/m

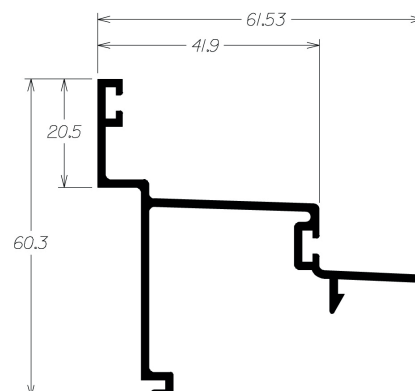

FC249

PINGADEIRA QUADRO
FIXO

0,569 Kg/m

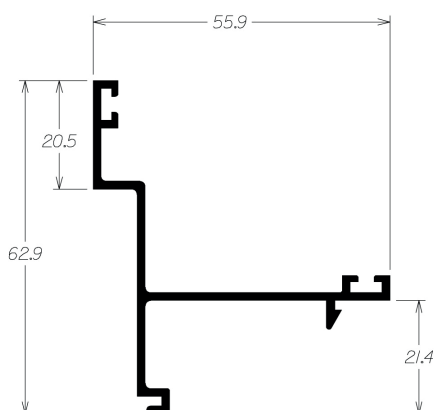

FC228

TRAVESSA HORIZONTAL

0,561 Kg/m

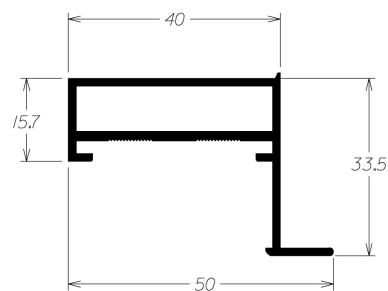

FC261

MONTANTE VERTICAL

0,493 Kg/m

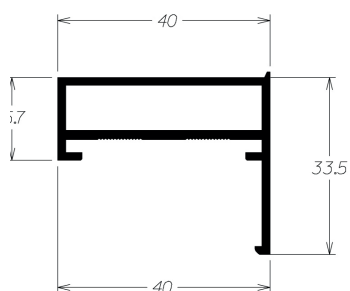

FC242

ARREIMATE EXTERNO

0,721 Kg/m

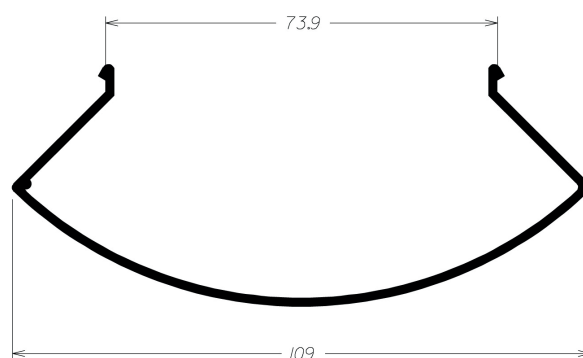

FC588

PINGADEIRA

0,461 Kg/m

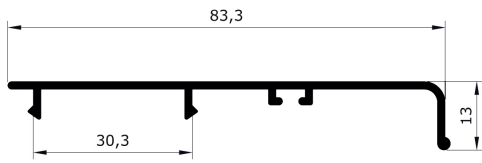

FC085

TAMPA DO ARREMATE
SOLEIRA

0,258 Kg/m

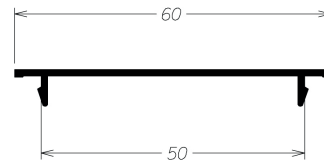

FC232

COLUNA 75x57

1,302 Kg/m

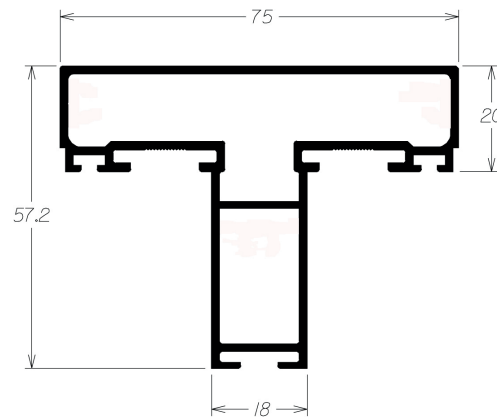

FC245

ARREMATE DE RODAPÉ

0,795 Kg/m

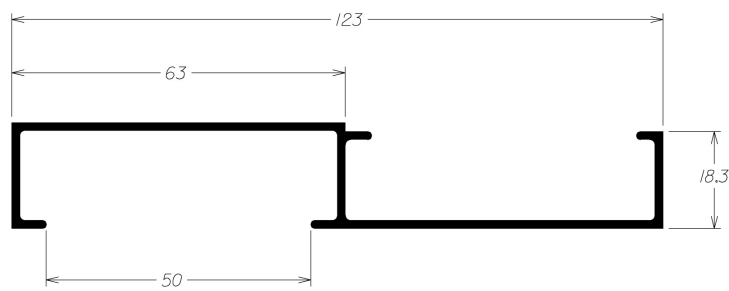

FC250

ARREMATE DE RODAPÉ

0,836 Kg/m

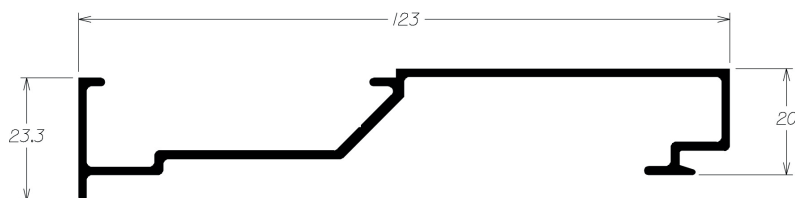

FC087

TAMPA DO ARREMATE

1,023 Kg/m

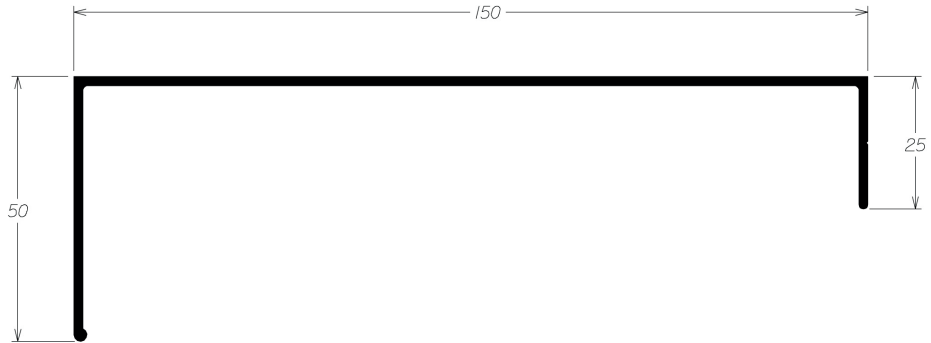

FC088

PERFIL RUFFO

0,904 Kg/m

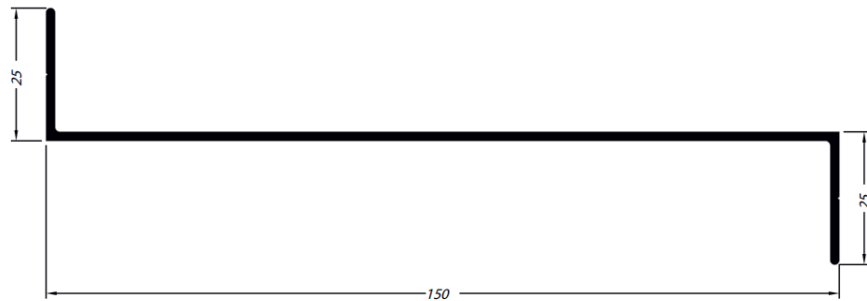

FC293

MONTANTE

0,616 Kg/m

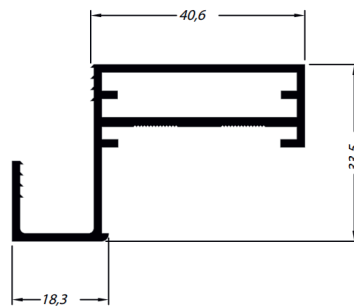

ESQUEMAS DE MONTAGEM

CORTE 01

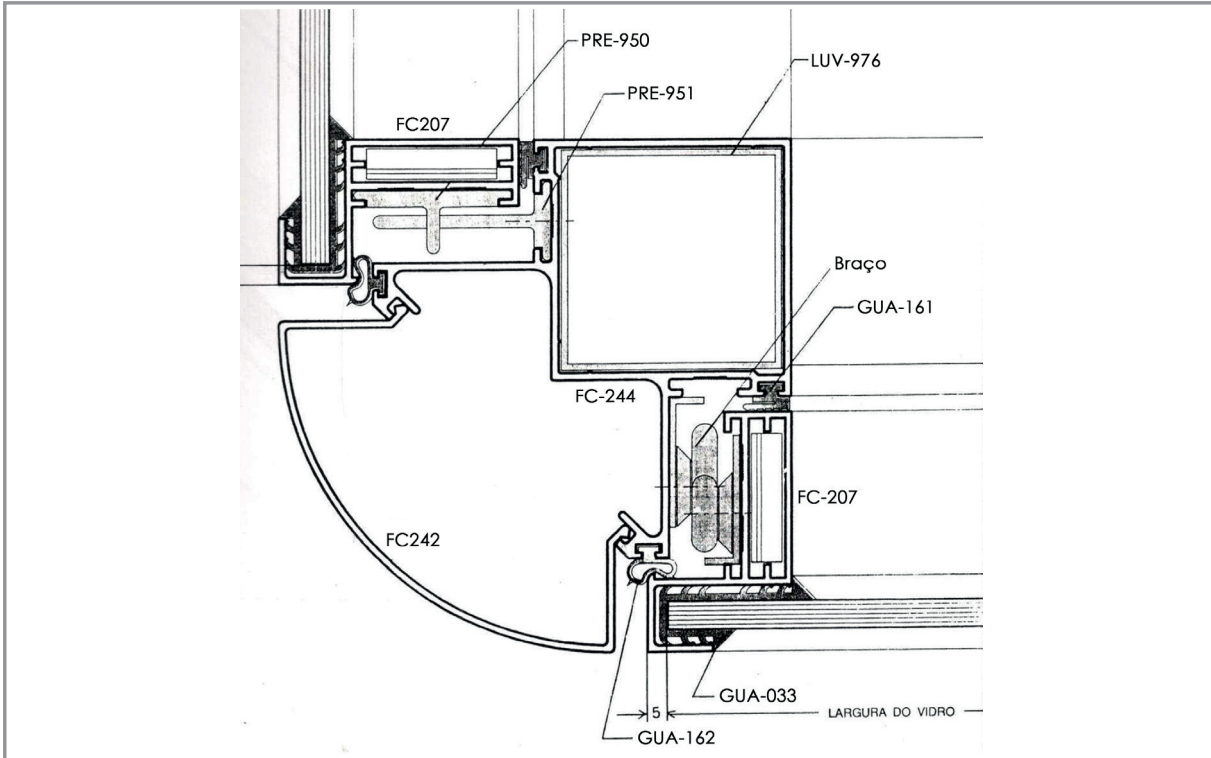

CORTE 02

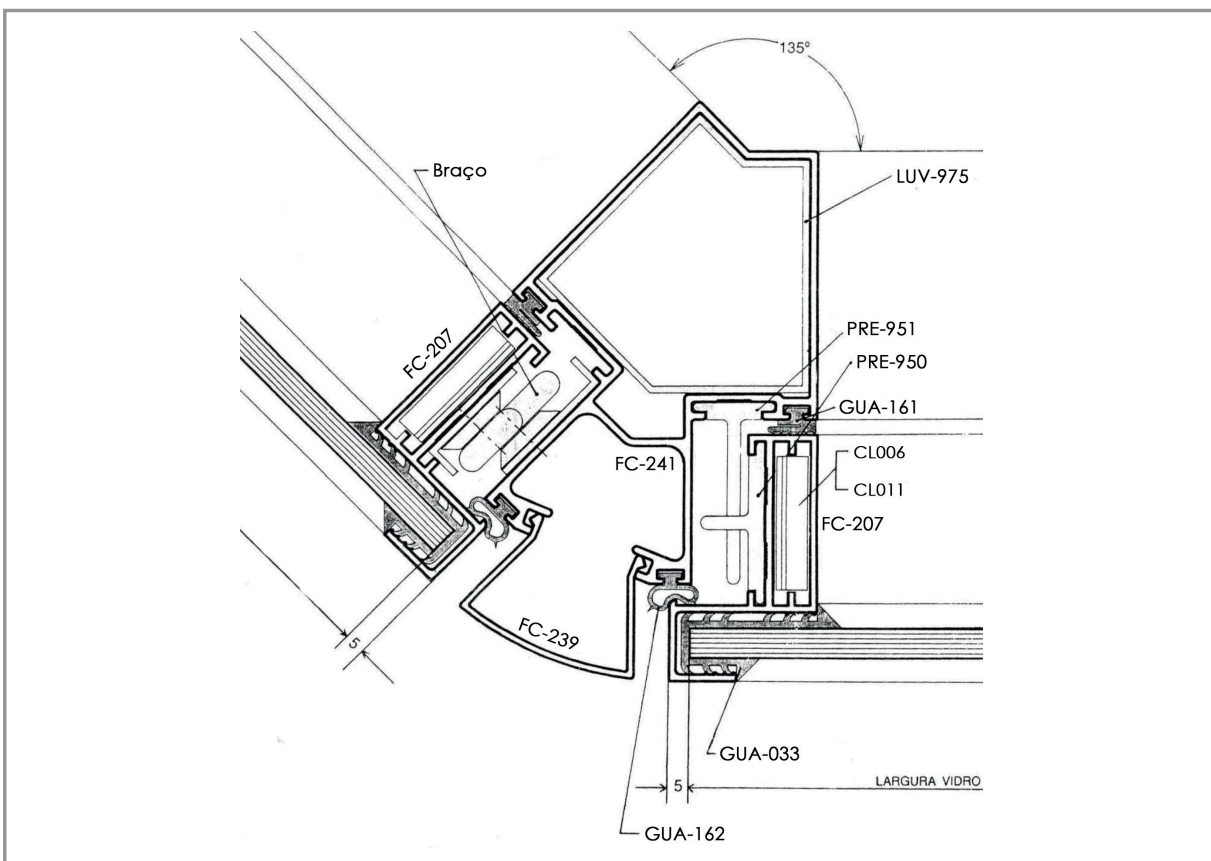

ESQUEMAS DE MONTAGEM

CORTE 03

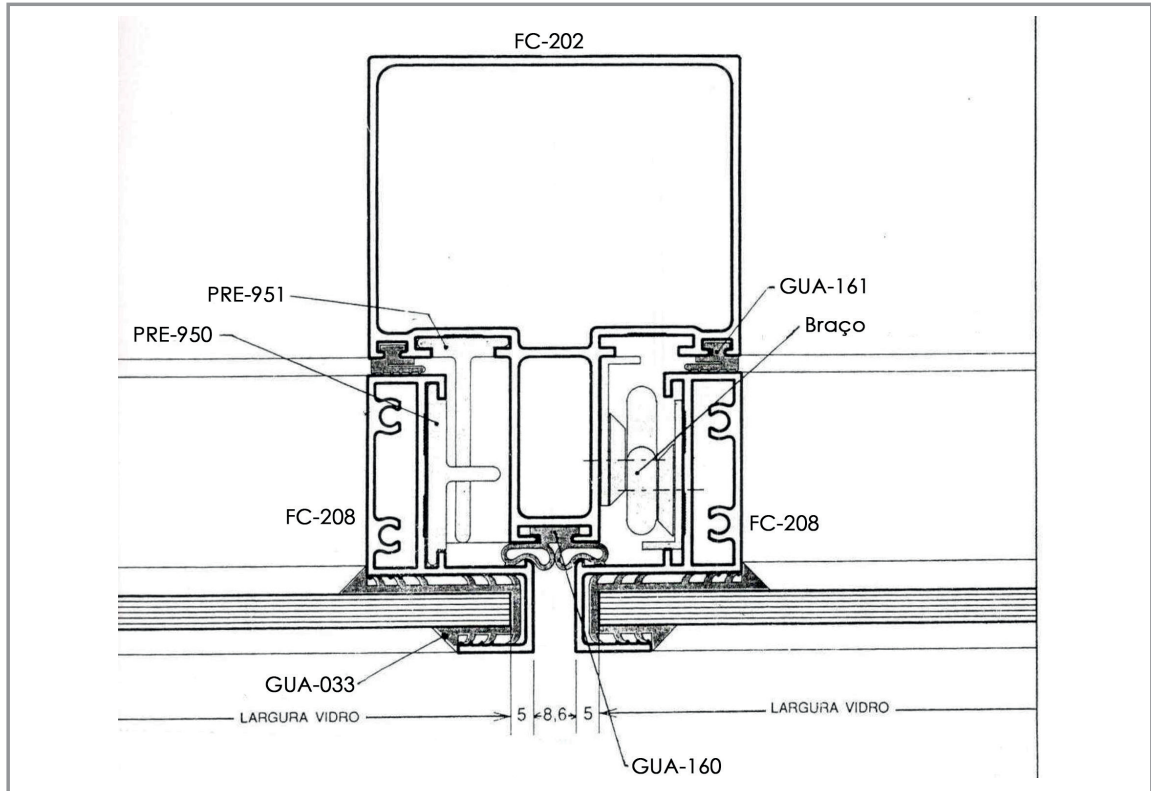

CORTE 04

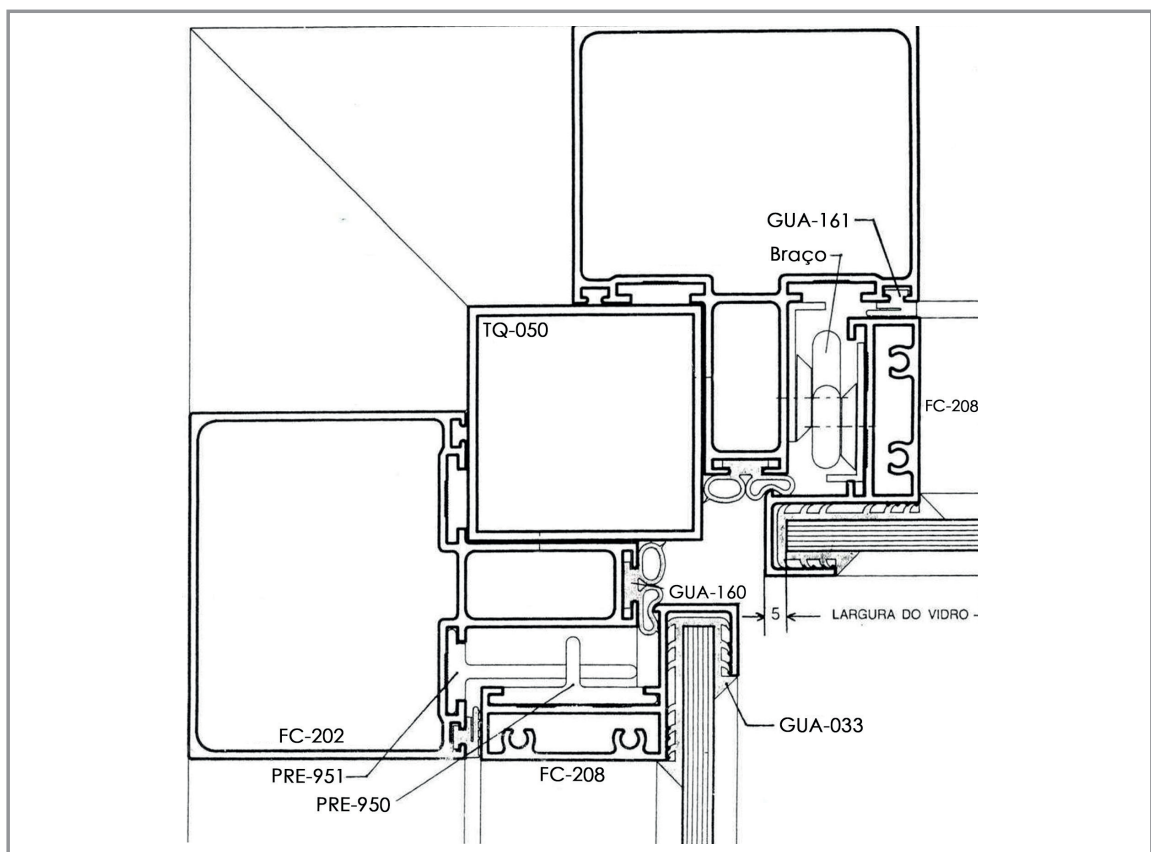

ESQUEMAS DE MONTAGEM

CORTE 05

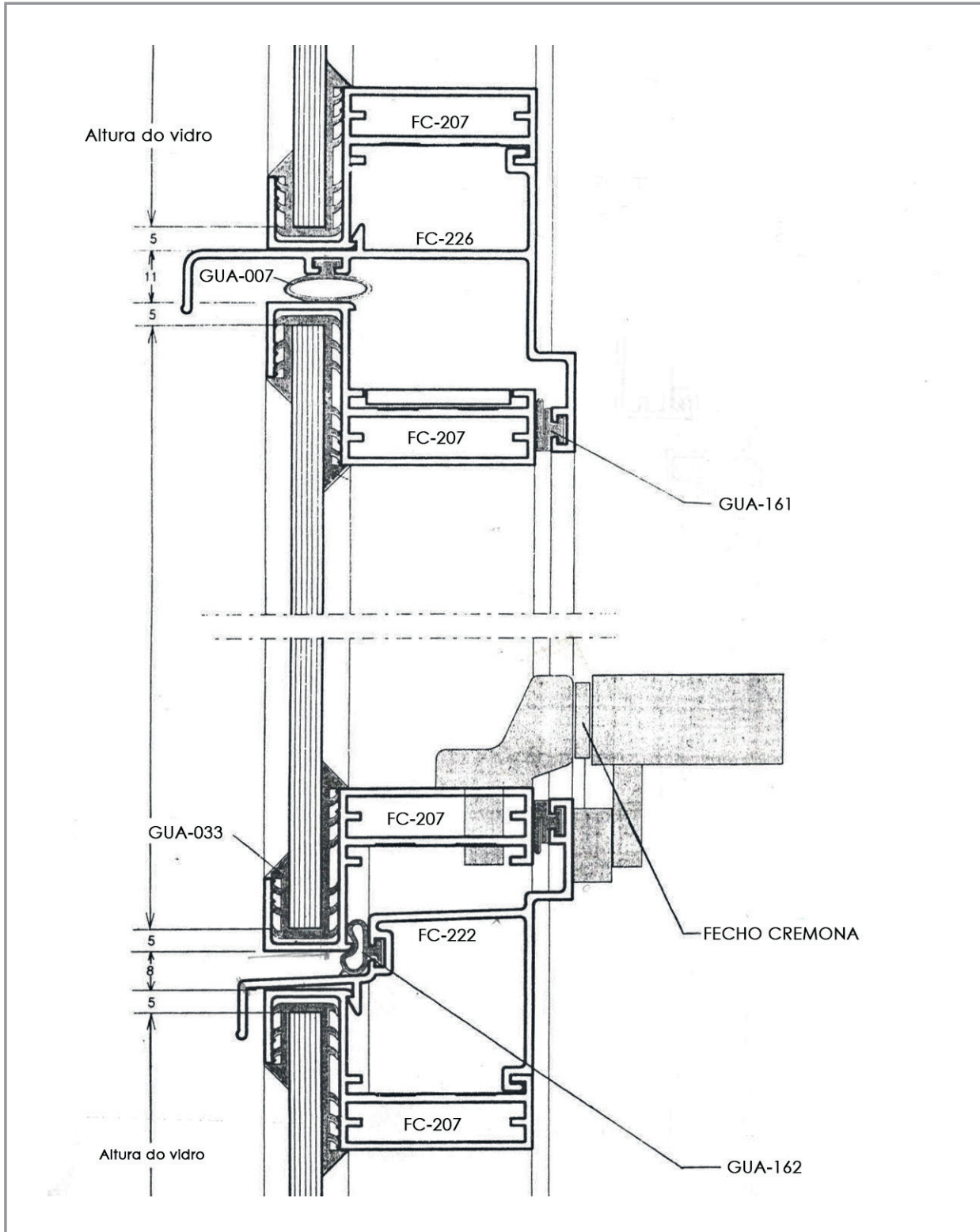

ESQUEMAS DE MONTAGEM

CORTE 06

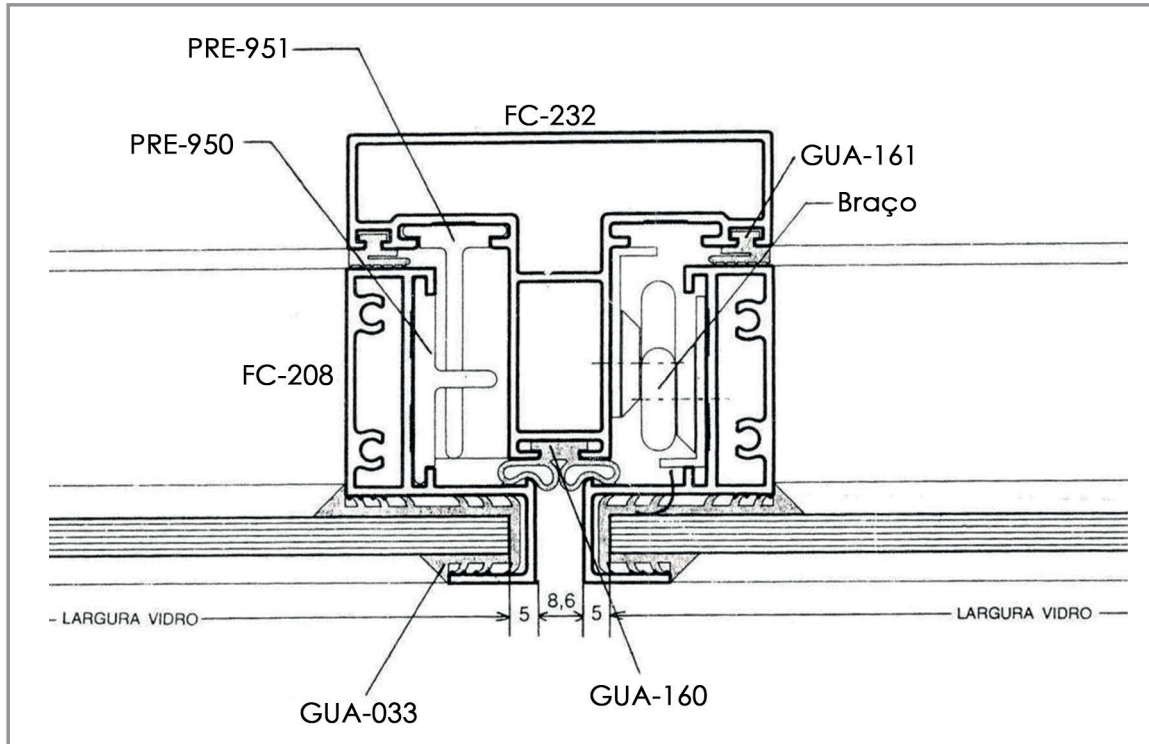

JP028

CAPA DE ACABAMENTO

0,160 Kg/m

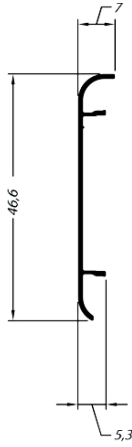

JP027

PERFIL U DE REGULAGEM

0,543 Kg/m

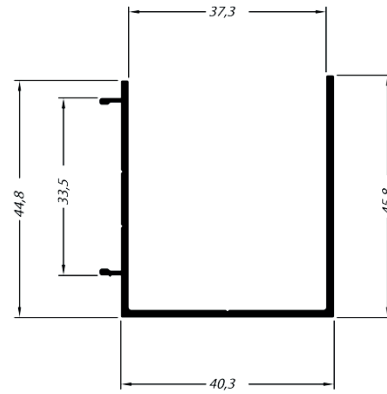

JP025

TRILHO INFERIOR

0,975 Kg/m

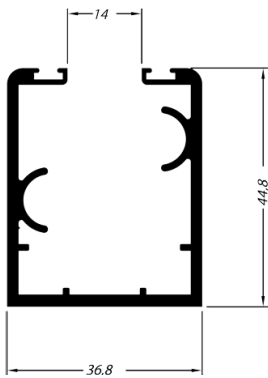

JP026

TRILHO SUPERIOR

1,208 Kg/m

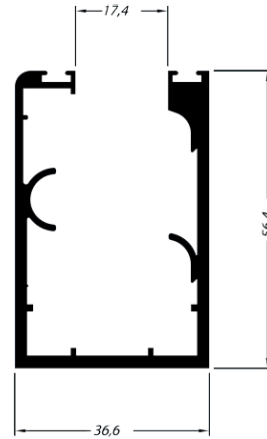

JP084

LEITO PARA VIDRO 10MM

0,496 Kg/m

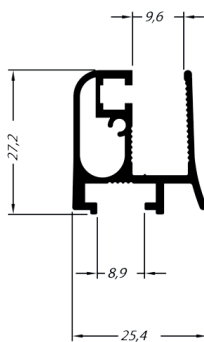

JP083

LEITO PARA VIDRO 08MM

0,488 Kg/m

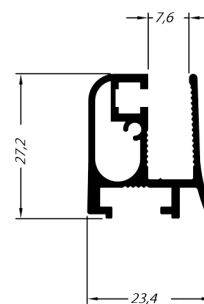

AFA390

COLUNA REFORÇADA

3,617 Kg/m

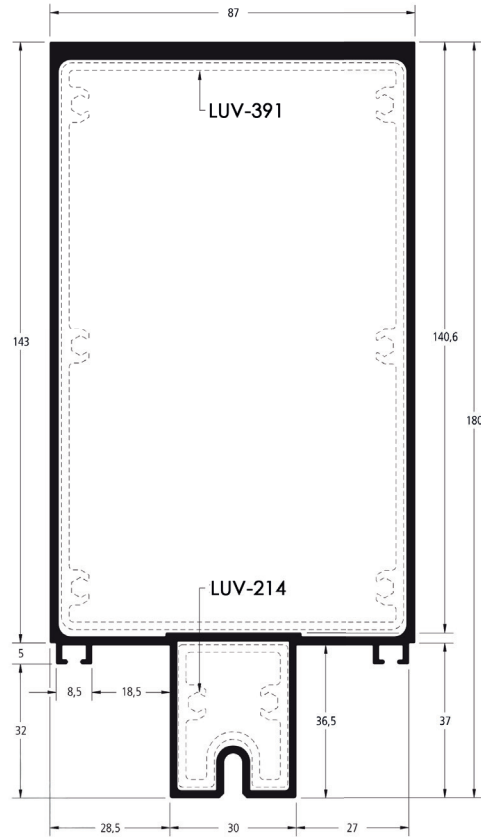

AFA265

ARREMATE INTERMEDIÁRIO

0,715 Kg/m

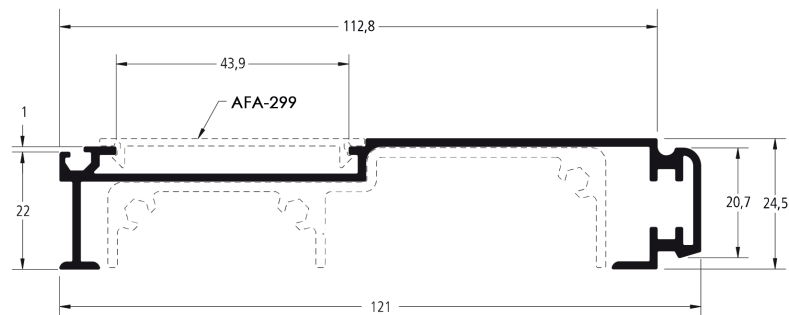

AFA236

COLUNA DE CANTO 90°

2,343 Kg/m

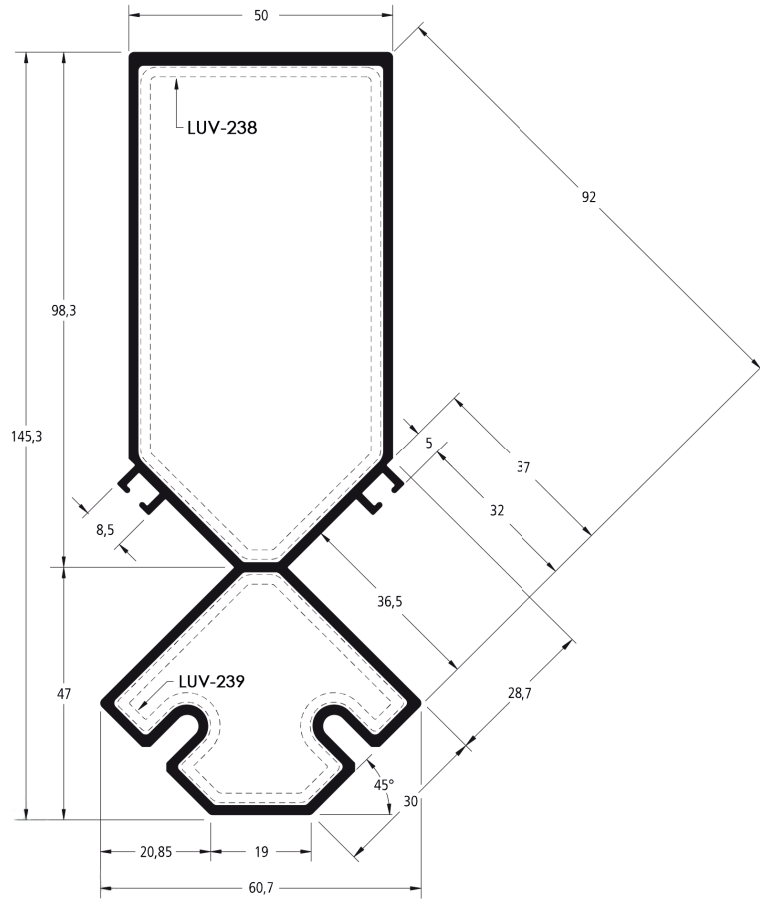

AFA200

COLUNA CENTRAL 92
x 87

1,825 Kg/m

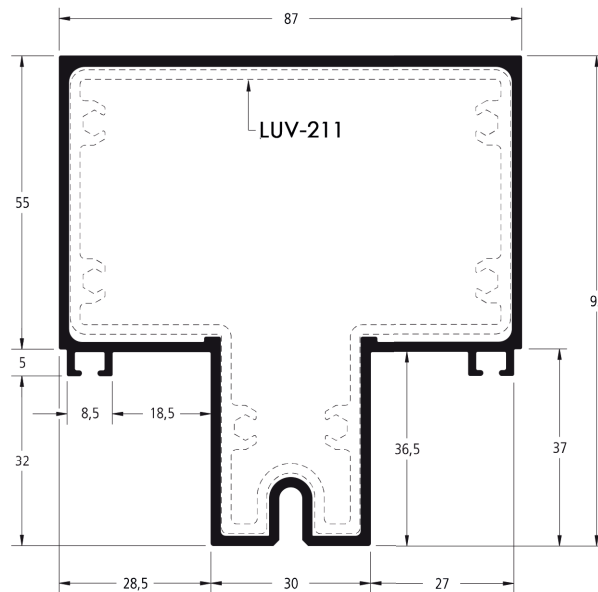

AFA233

TRAVESSA INTERMEDIÁRIA

0,886 Kg/m

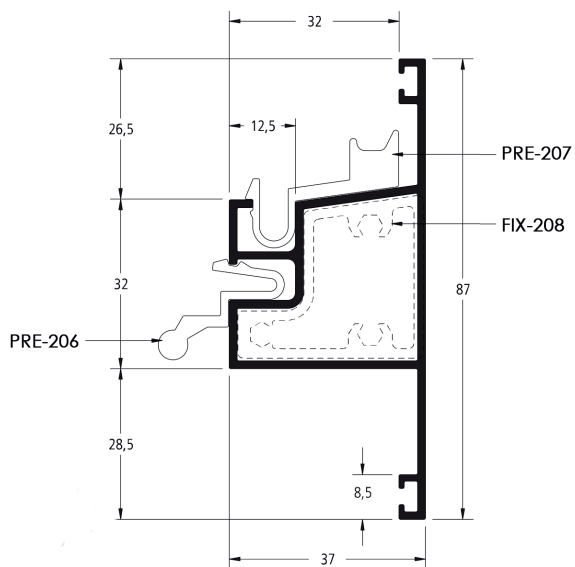

AFA228

MONTANTE DA FOLHA
FIXA

0,572 Kg/m

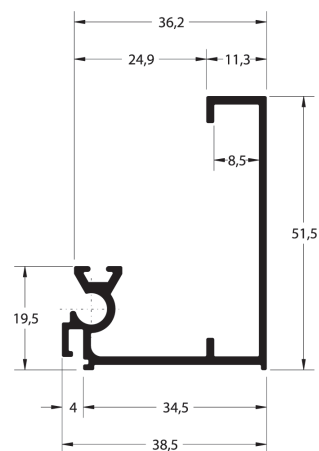

AFA232

TRAVESSA SUP e INF FIXO

0,607 Kg/m

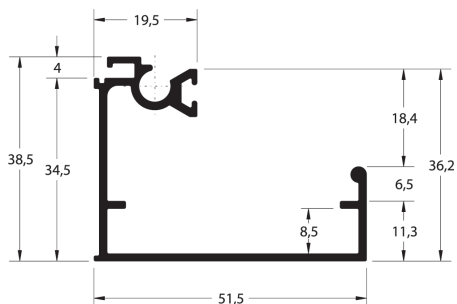

AFA204

COLUNA CENTRAL

1,038 Kg/m

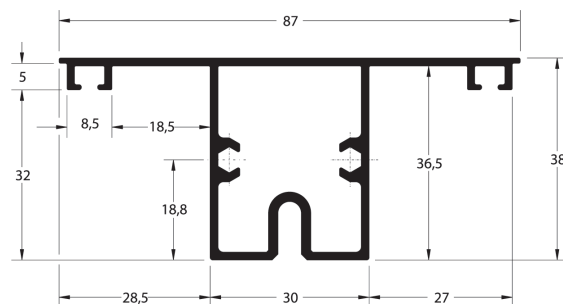

AFA205

COLUNA CENTRAL

0,935 Kg/m

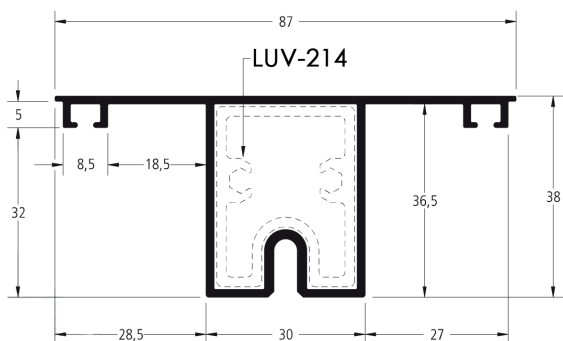

AFA230

TRAVESSA SUP-INF
MOVEL

0,771 Kg/m

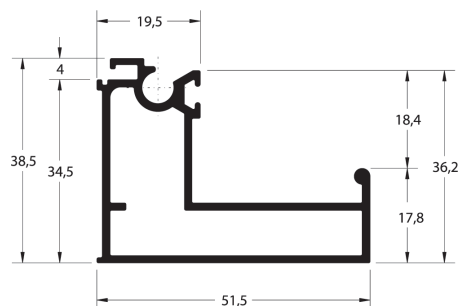

AFA245

MONTANTE DA FOLHA
MOVEL

0,775 Kg/m

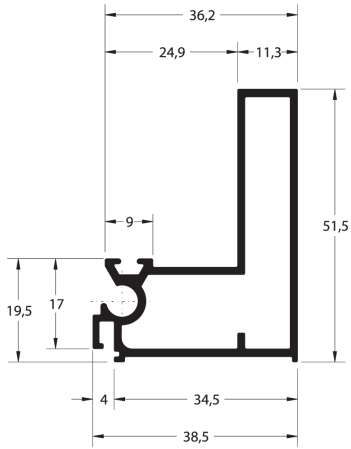

AFA237

TAMPA DO ARREMATE
INTERNO

0,116 Kg/m

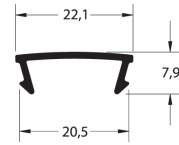

AFA238

ARREMATE INTERNO

0,519 Kg/m

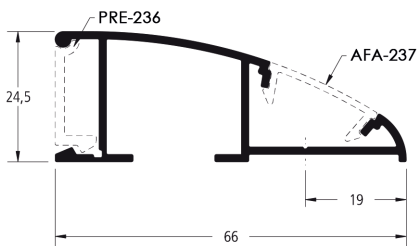

AFA239

ARREMATE
INTERMEDIÁRIO

0,646 Kg/m

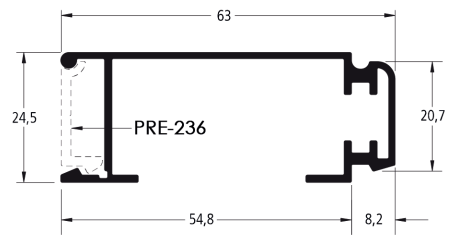

AFA242

COLUNA CENTRAL

1,367 Kg/m

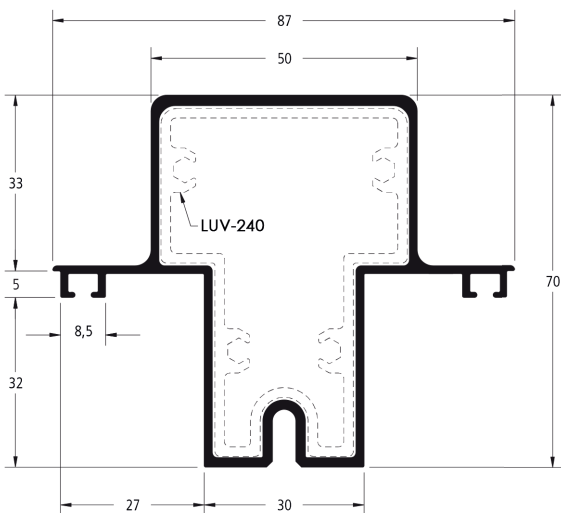

AFA377

ARREMATE
INTERMEDIÁRIO

0,714 Kg/m

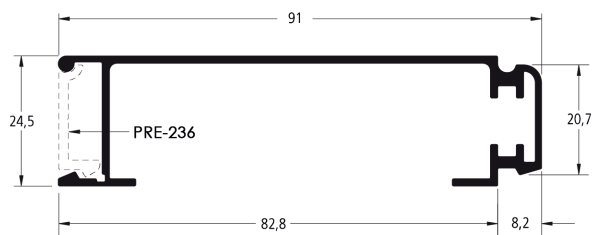

AFA294

MARCO PERIFÉRICO

0,774 Kg/m

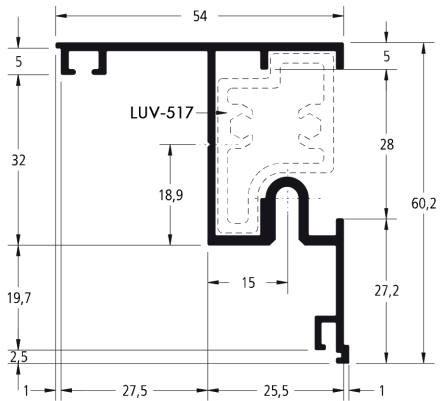

AFA235

MARCO LATERAL

1,279 Kg/m

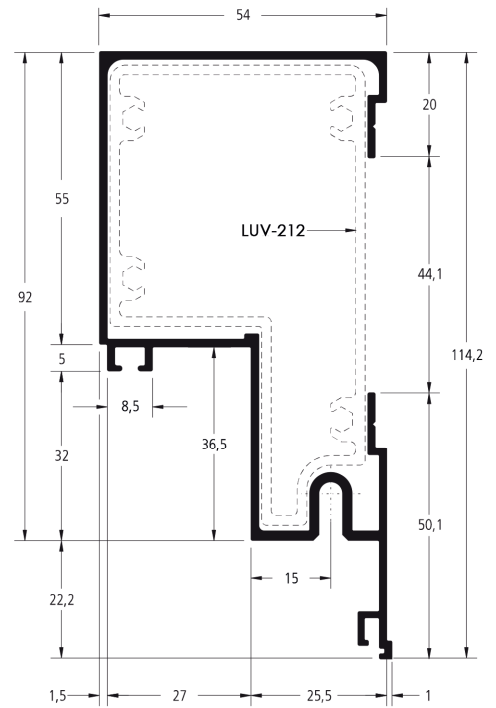

AFA260

MARCO LATERAL

0,860 Kg/m

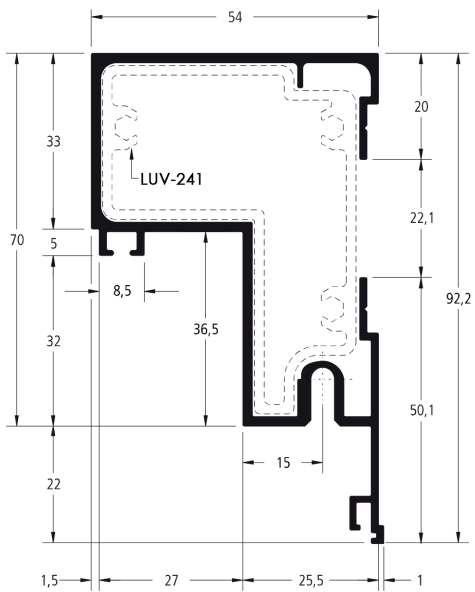

AFA511

MARCO LATERAL

1,250 Kg/m

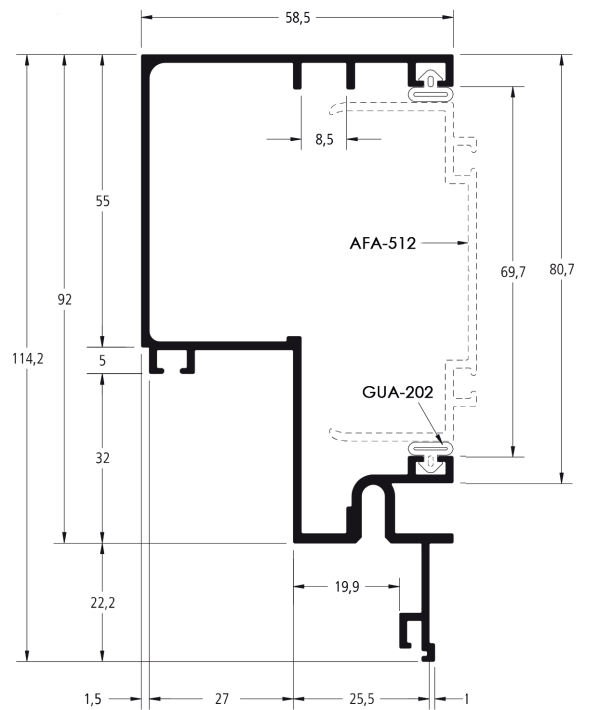

AFA512

FIXADOR DA COLUNA

0,510 Kg/m

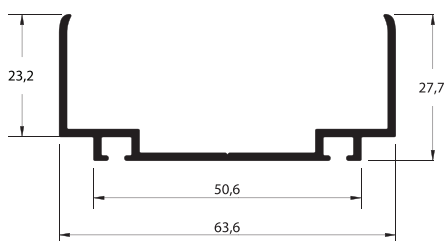

ESQUEMAS DE MONTAGEM

CORTE 01

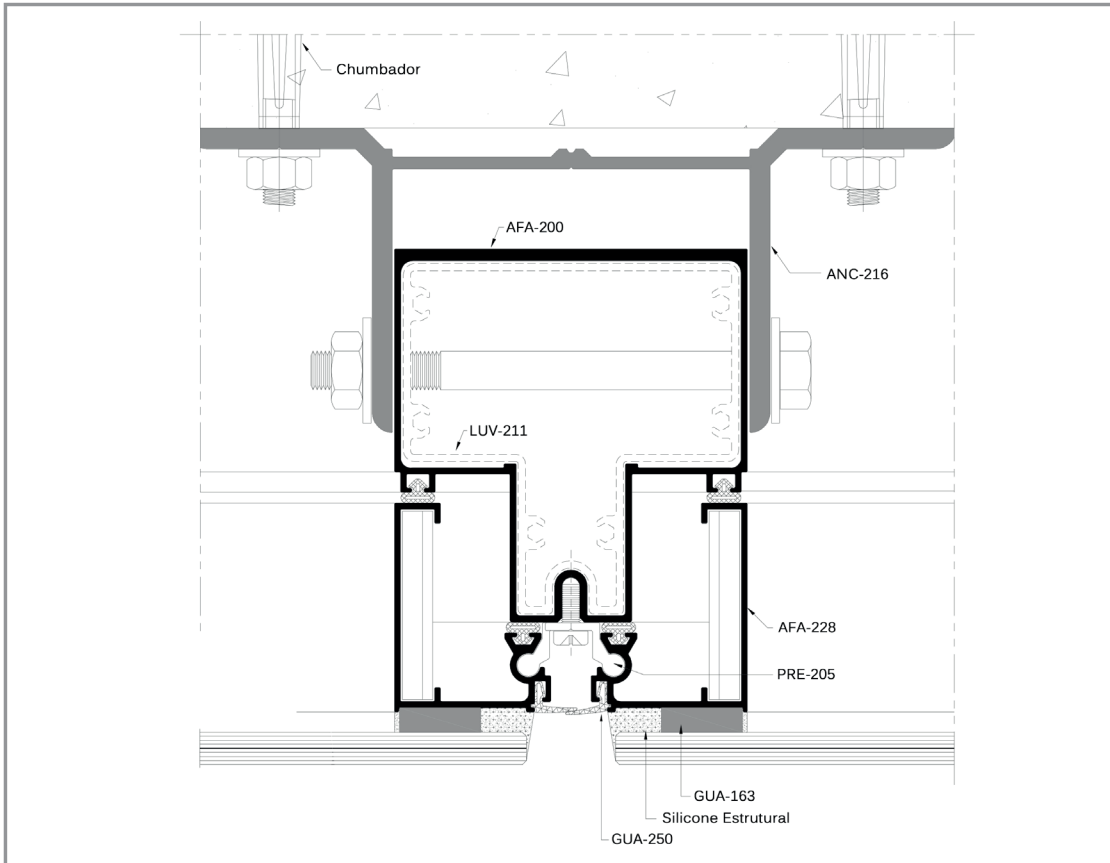

CORTE 02

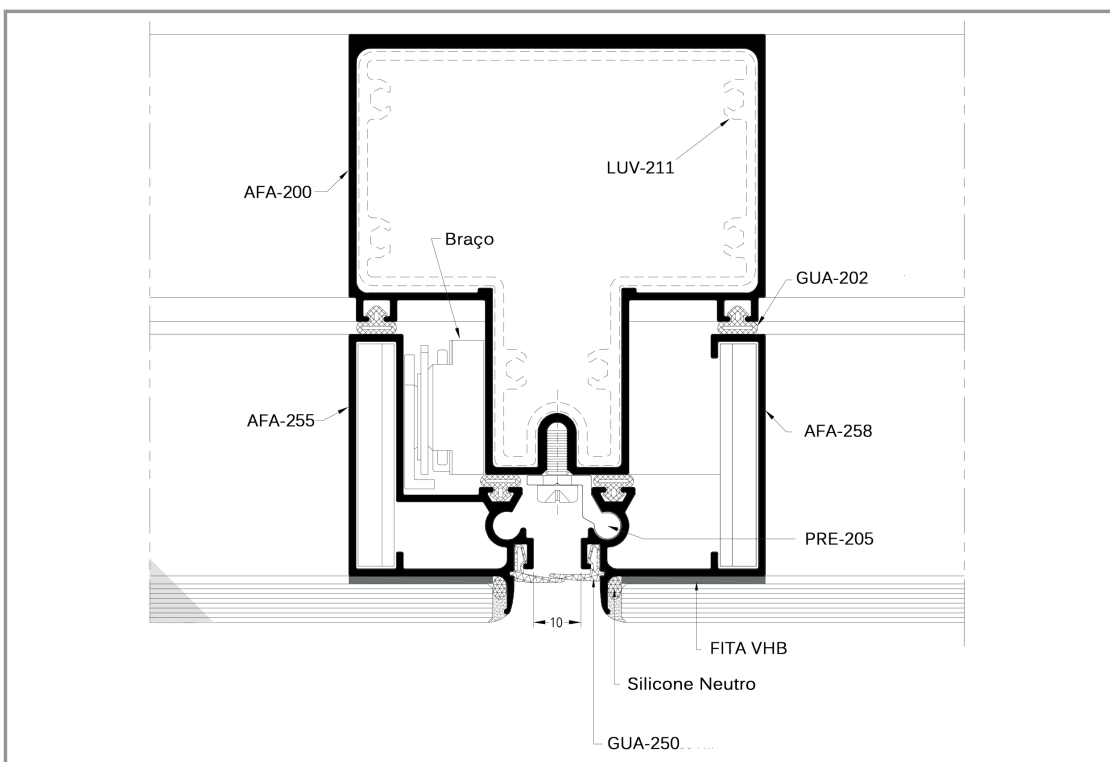

ESQUEMAS DE MONTAGEM

CORTE 03

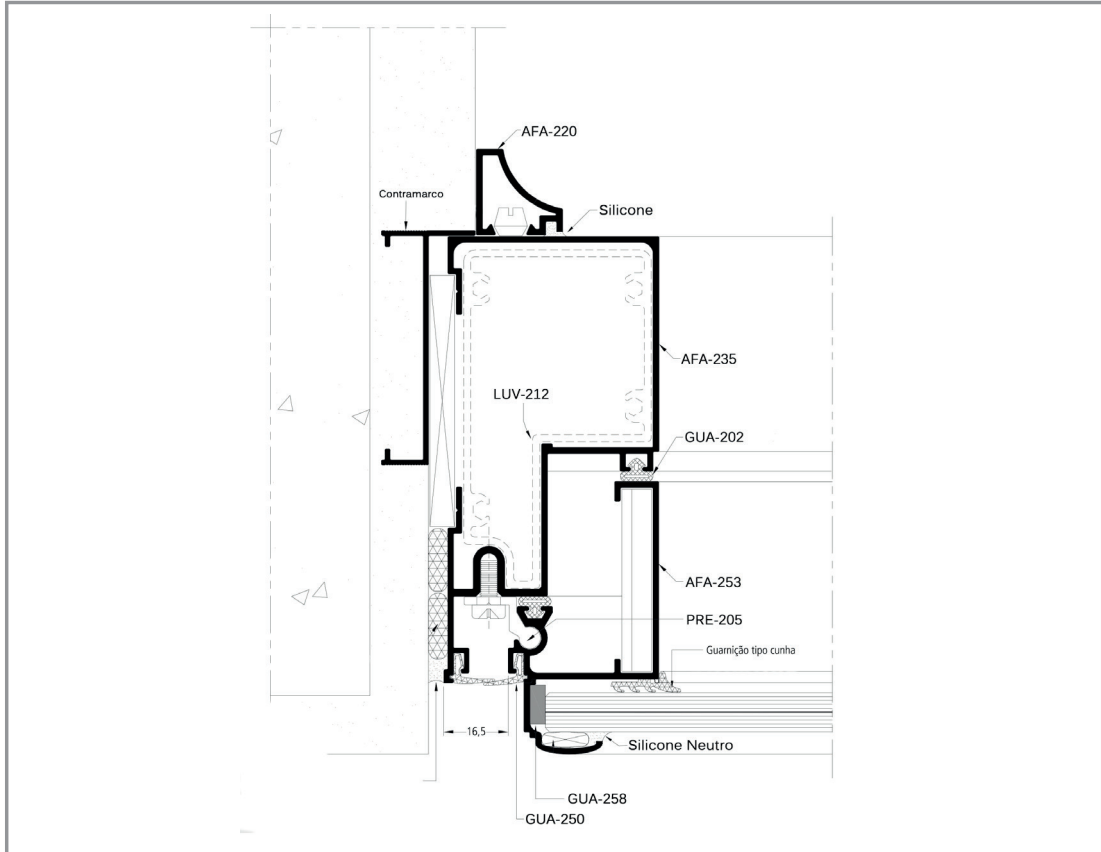

CORTE 04

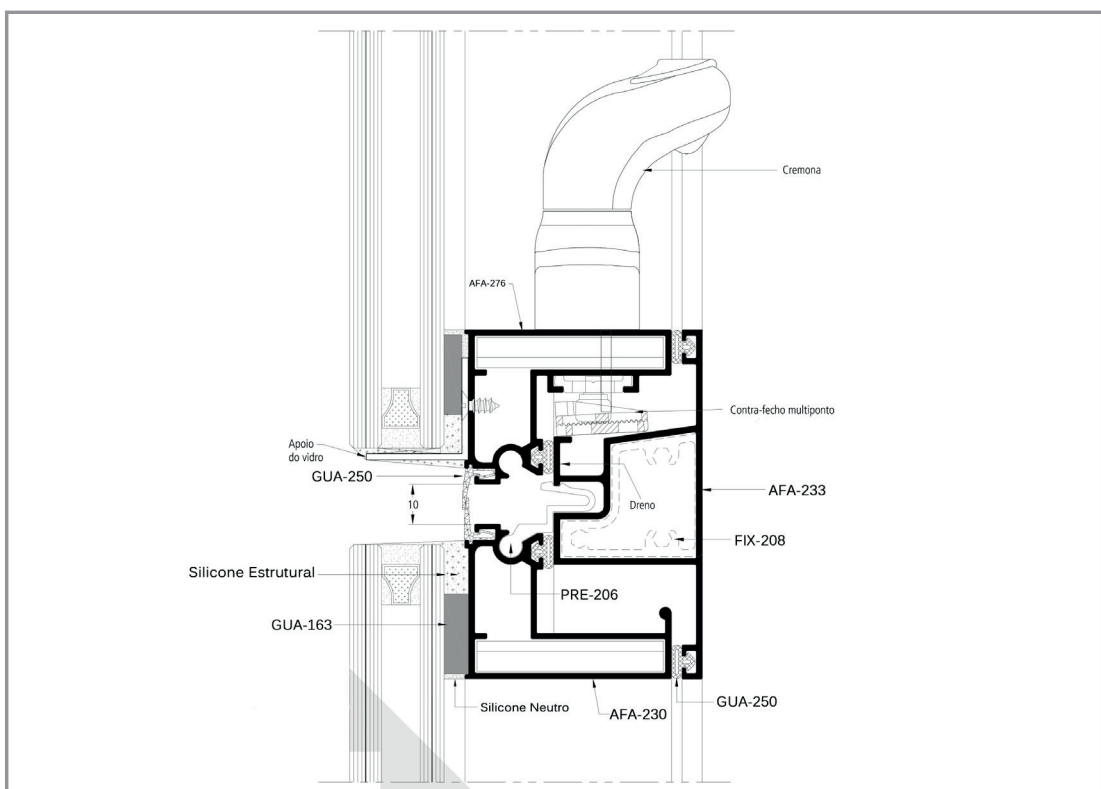

ESQUEMAS DE MONTAGEM

CORTE 05

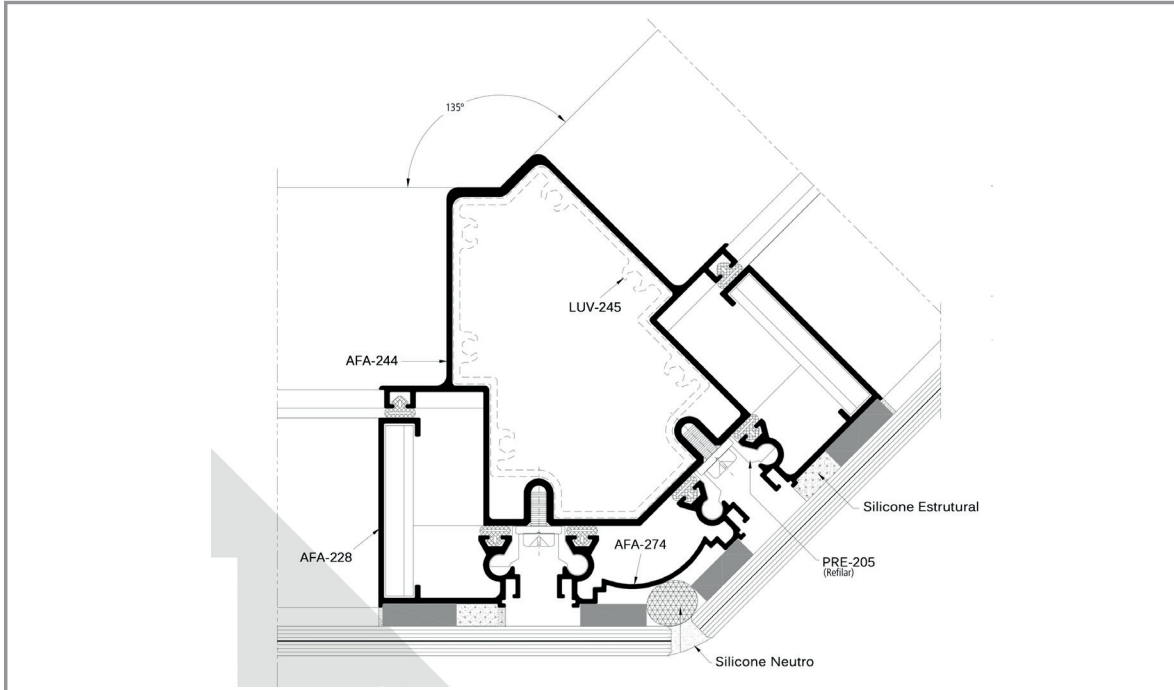

CORTE 06

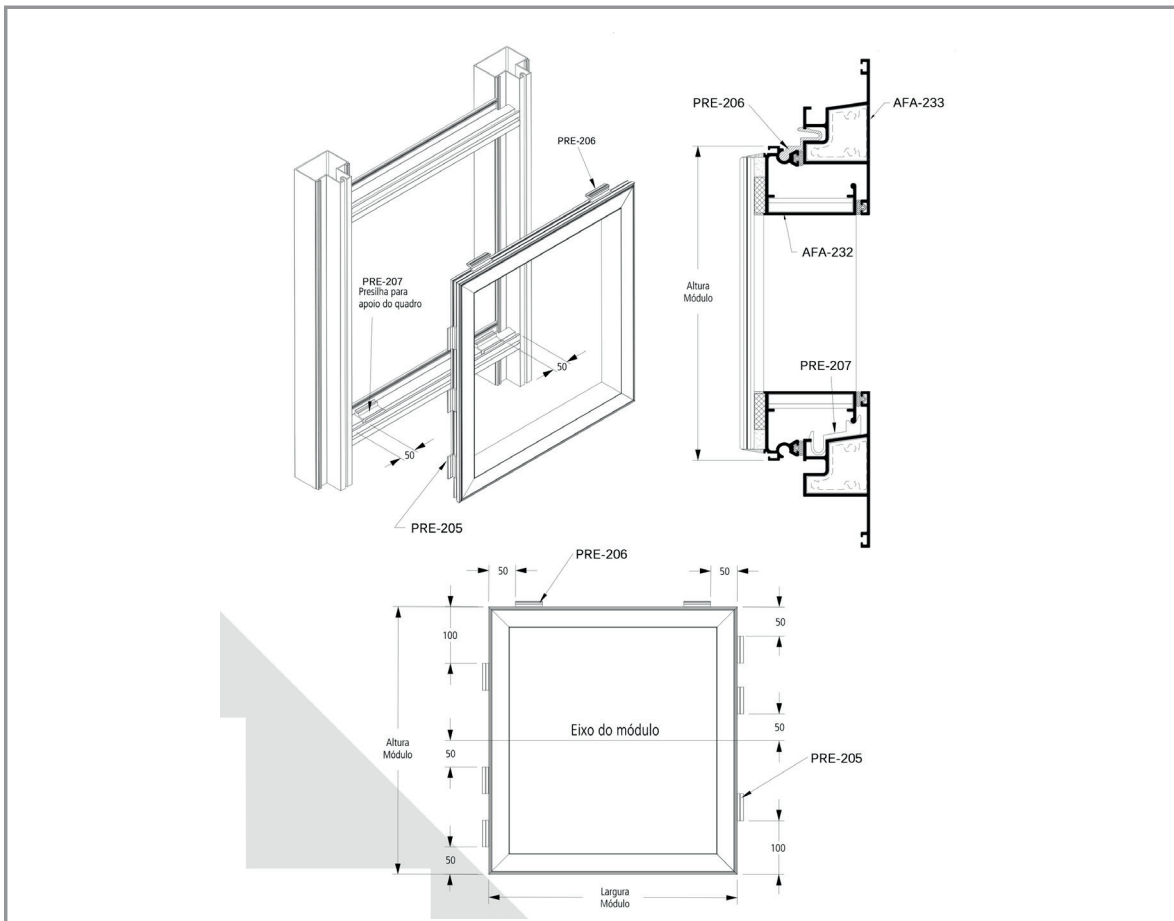

ESQUEMAS DE MONTAGEM

CORTE 07

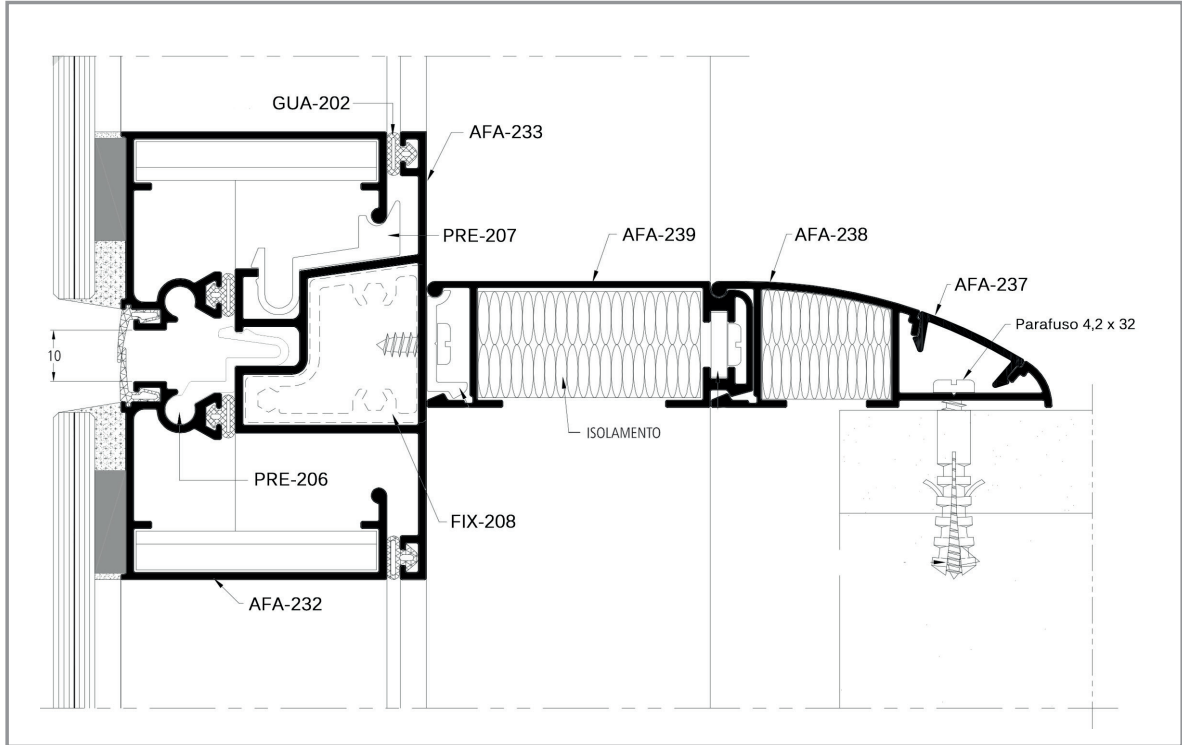

CORTE 08

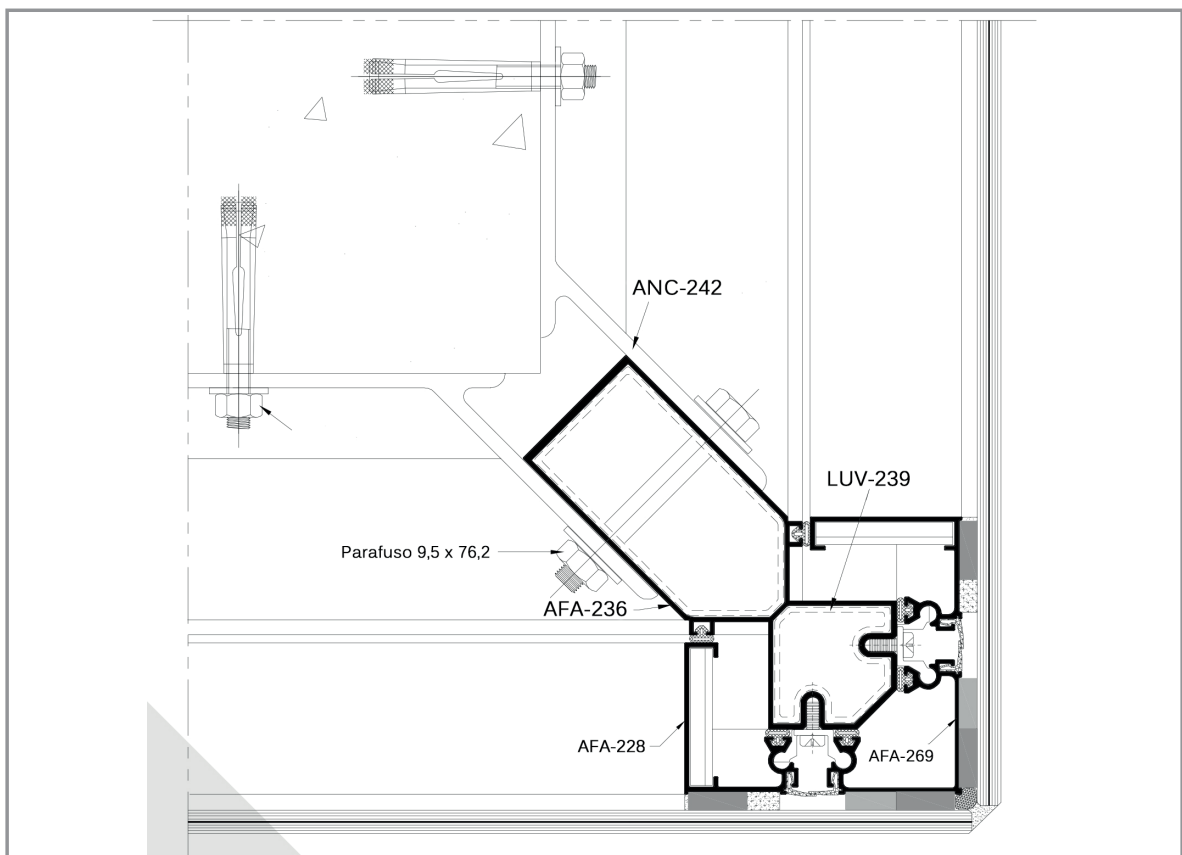

2131

PERFIL TRAPÉZIO

0,265 Kg/m

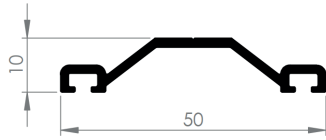

2681

PERFIL ONDULADO

0,210 Kg/m

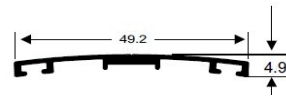

664 AL

PERFIL U PARA 06mm

0,146 Kg/m

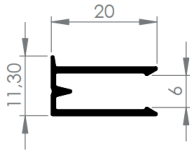

663 AL

PERFIL U PARA 10mm

0,137 Kg/m

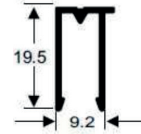

664U

PERFIL U 06mm



663U

PERFIL U 10mm

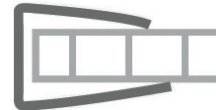

5890

PERFIL H 06mm

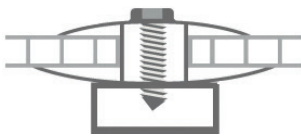

5891

PERFIL H 10mm

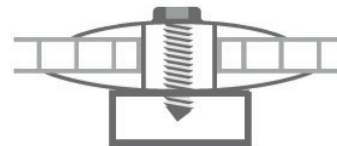

BOLD

o mundo nos inspira

AP49L

TRILHO SUPERIOR LEVE

0,487 Kg/m

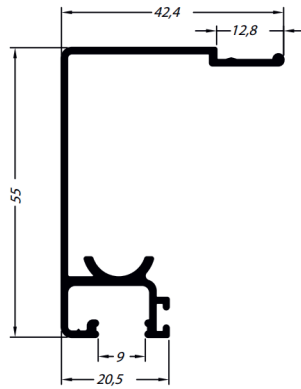

AP49A

TRILHO SUPERIOR

0,598 Kg/m

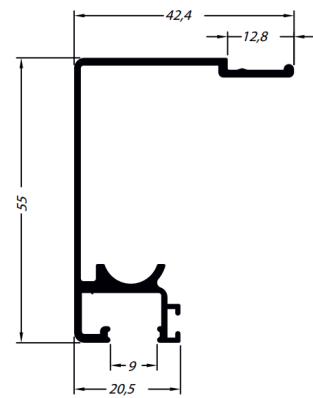

AP50A

CAPA

0,258 Kg/m

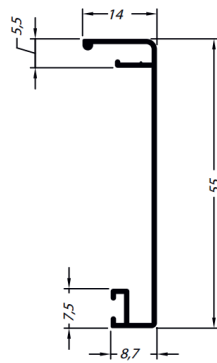

AP45

TRILHO INFERIOR

0,291 Kg/m

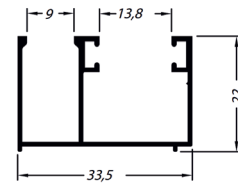

AP140

TRILHO INFERIOR COM
GUIA

0,291 Kg/m

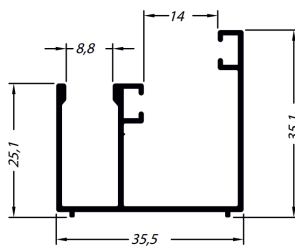

AP43

CLICK

0,079 Kg/m

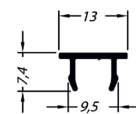

AP16

TRANSPASSE LEVE

0,094 Kg/m

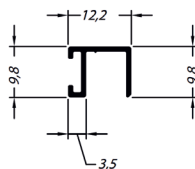

AP46

TRANSPASSE

0,111 Kg/m

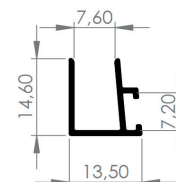

AP40

0,202 Kg/m

TRANSPASSE MÃO
AMIGA

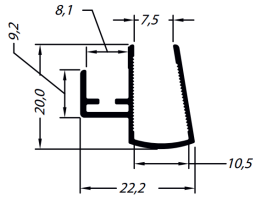

AP63

0,139 Kg/m

CADERINHA LEVE

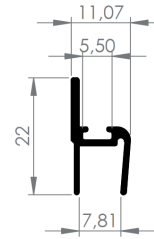

AP47

0,175 Kg/m

CADERINHA

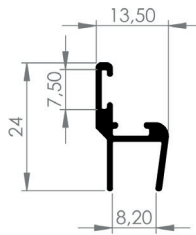

AP44

0,088 Kg/m

BAGUETE

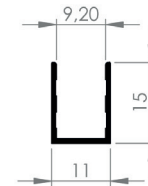

AP66

0,120 Kg/m

BAGUETE

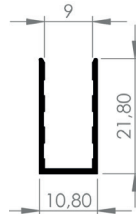

AP01

TRILHO SUPERIOR
PESADO

1,000 Kg/m

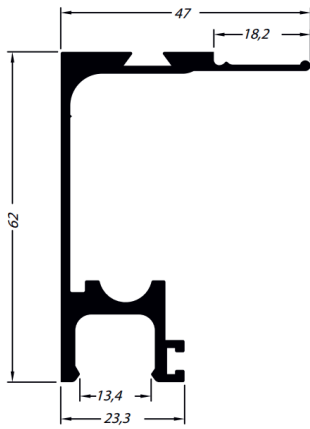

AP51A

TRILHO SUPERIOR

0,656 Kg/m

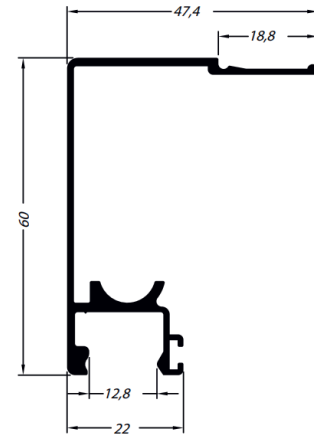

AP52A

CAPA

0,280 Kg/m



AP05

TRILHO INFERIOR

0,347 Kg/m

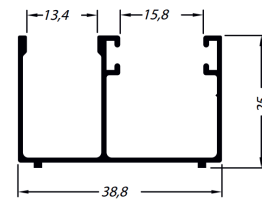

AP141

TRILHO INFERIOR COM
GUIA

0,443 Kg/m

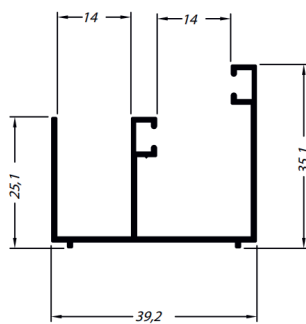

AP13

CLICK

0,095 Kg/m

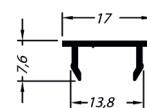

AP15

0,152 Kg/m

TRANSPASSE LEVE

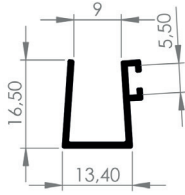

AP14

0,194 Kg/m

TRANSPASSE

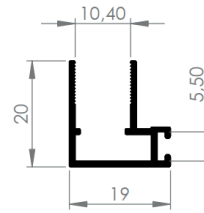

AP41

0,215 Kg/m

TRANSPASSE MÃO AMIGA

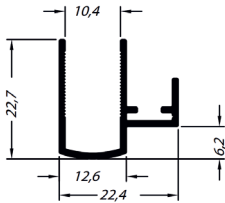

AP17

0,225 Kg/m

CADEIRINHA

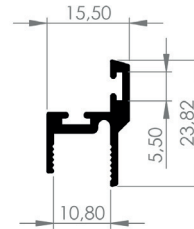

AP227

0,128 Kg/m

BAGUETE

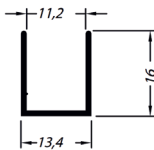

AP12

0,138 Kg/m

BAGUETE

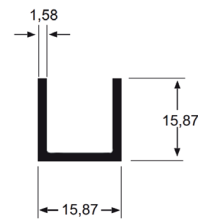

AP109

0,145 Kg/m

BAGUETE

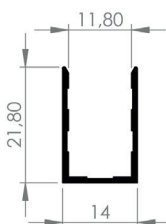

AP806

0,178 Kg/m

BAGUETE

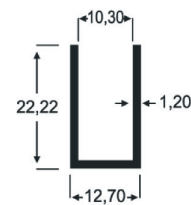

AP10

0,187 Kg/m

BAGUETE

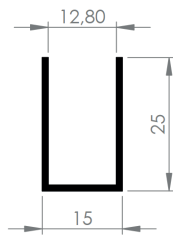

AP11

0,334 Kg/m

BAGUETE

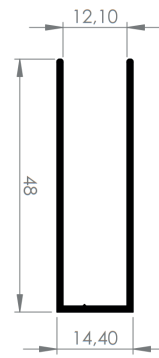

AP60A

TRILHO SUPERIOR

0,537 Kg/m

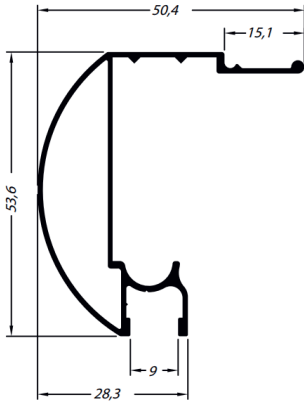

AP61A

CAPA

0,210 Kg/m

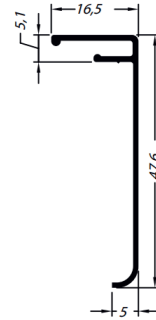

AP62

TRILHO INFERIOR

0,264 Kg/m

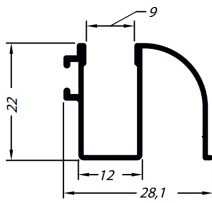

AP65

CLICK

0,040 Kg/m

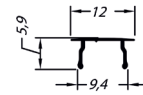

AP64

CADEIRINHA

0,136 Kg/m

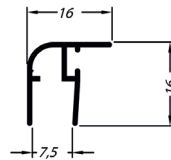

AP172

TRILHO SUPERIOR

1,176 Kg/m

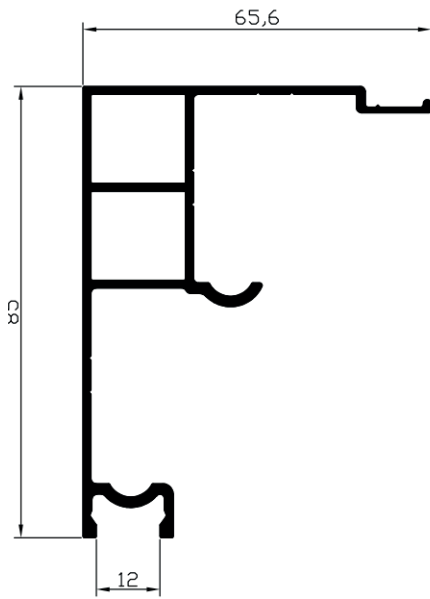

AP171

CAPA

0,300 Kg/m

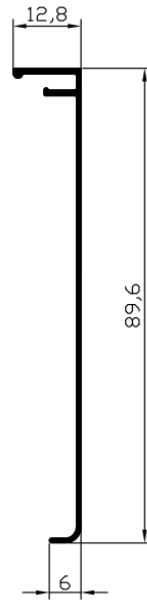

AP67

TRILHO SUPERIOR MÃO AMIGA

0,864 Kg/m

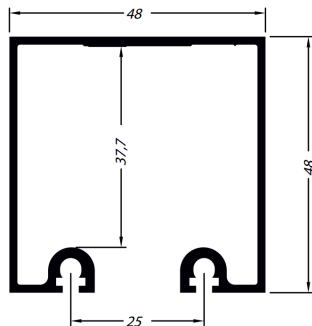

AP68

TRILHO SUPERIOR MÃO AMIGA

1,053 Kg/m

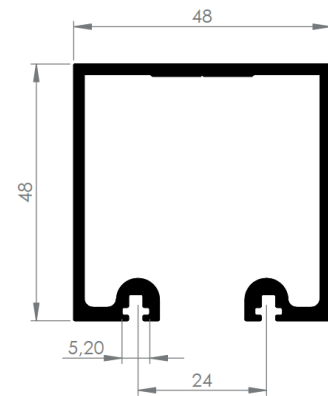

AP37

TRILHO STANLEY

0,635 Kg/m

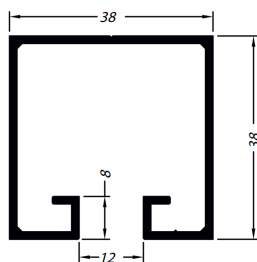

AP37A

TRILHO STANLEY

0,635 Kg/m

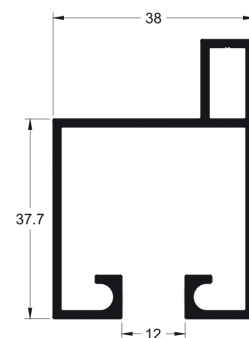

AP268
TRILHO SUPERIOR
1,654Kg/m

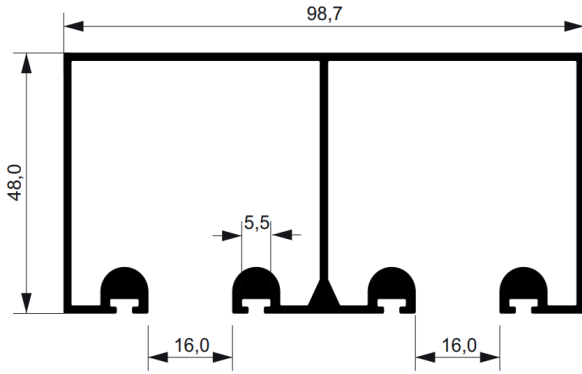

AP239
TRILHO SUPERIOR
1003 Kg/m

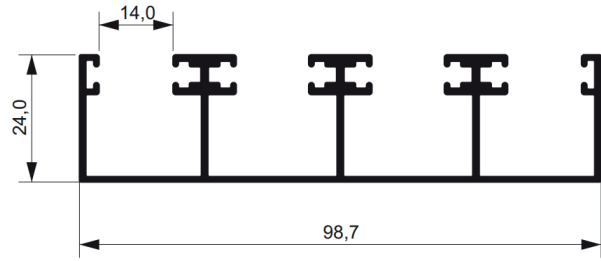

AP38
TRILHO INFERIOR DUPLO
08mm
0,316 Kg/m

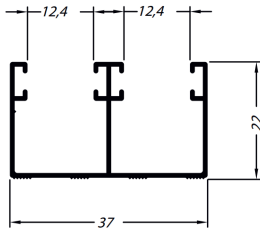

AP39
TRILHO INFERIOR DUPLO
10mm
0,512 Kg/m

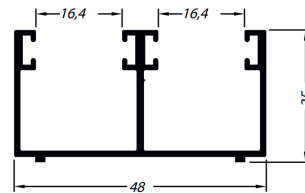

AP06
TRILHO INFERIOR SIMPLES
0,296 Kg/m

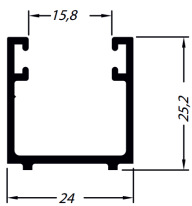

AP25
CANTONEIRA COM
ESCOVA
0,145 Kg/m

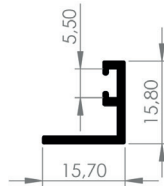

AP22
BAGUETE COM ESCOVA
0,146 Kg/m

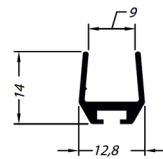

AP26
CANTONEIRA
0,237 Kg/m

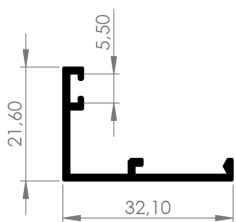

AP27
BAGUETE
0,237 Kg/m

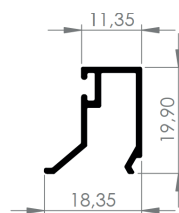

AP73
PERFIL PARA TELA
0,232 Kg/m

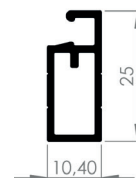

AP83

SUPERIOR RETANGULAR

1,157 Kg/m

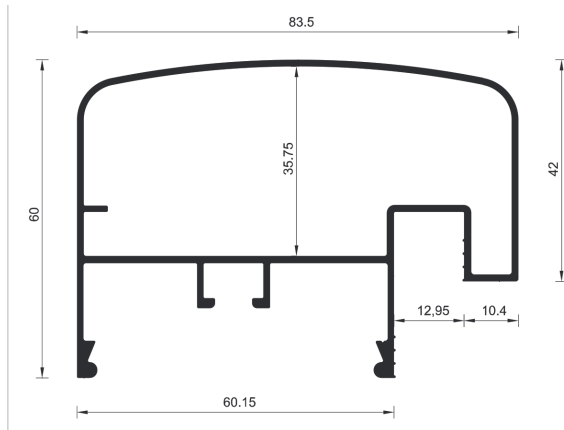

AP84

SUPERIOR REDONDO

1,040 Kg/m

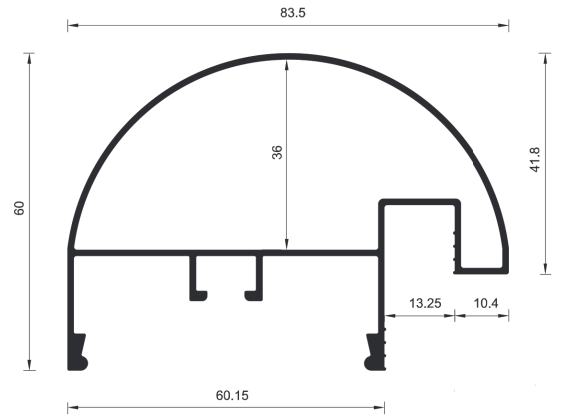

AP77

PONTALETE

0,708 Kg/m

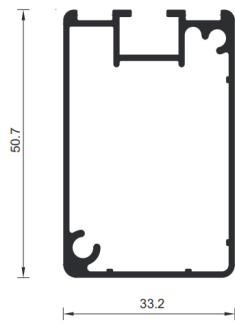

AP75

PERFIL J

0,465 Kg/m

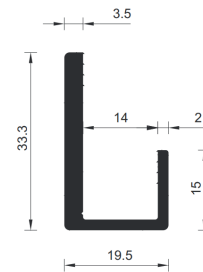

AP74

CAPA

0,232 Kg/m



AP839

SUPERIOR

1,063 Kg/m

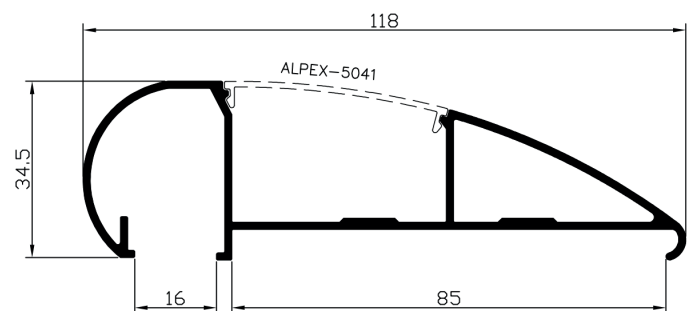

AP833
0,993 Kg/m
PONTALETE

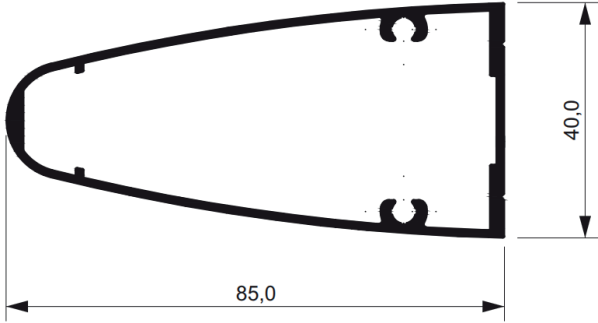

AP841
0,156 Kg/m
CAPA

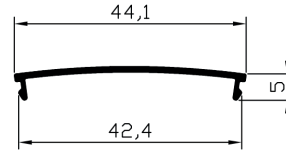

AP826
0,354 Kg/m
PERFIL J

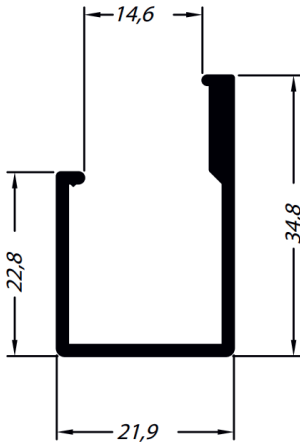

AP78
0,402 Kg/m
SUPERIOR

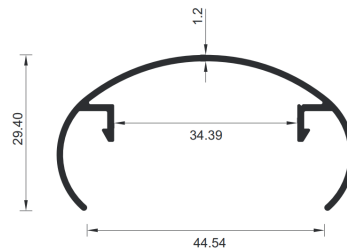

AP79
0,311 Kg/m
CAPA

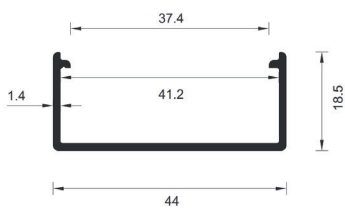

AP71
0,487 Kg/m
SUPERIOR REDONDO

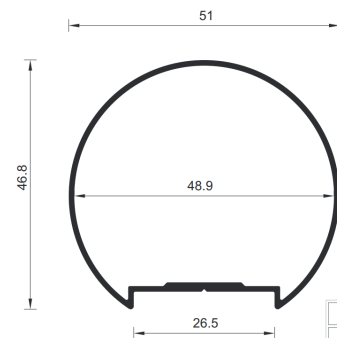

AP03

SUPERIOR

0,499 Kg/m

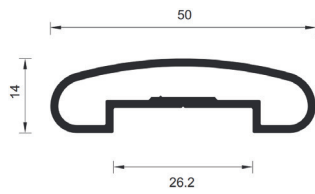

AP88

TUBO COM OLHAL

0,443 Kg/m

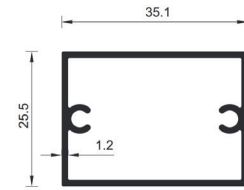

AP21

TUBO COM OLHAL

0,299 Kg/m

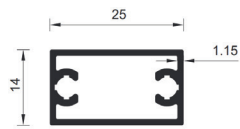

CG104

TUBO COM OLHAL

0,794 Kg/m

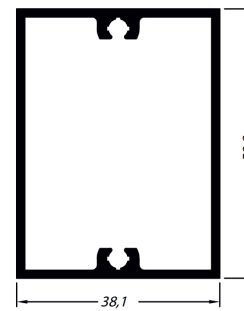

AP86

TRILHO SUPERIOR

0,440 Kg/m

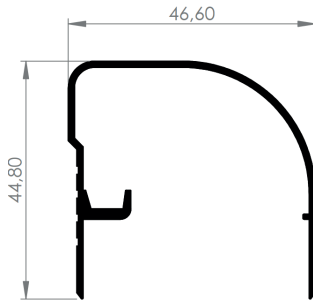

AP460

TRILHO INFERIOR

0,182 Kg/m

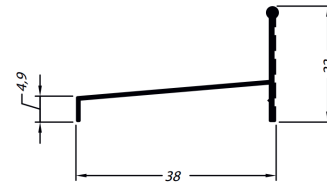

AP85

LATERAL

0,162 Kg/m

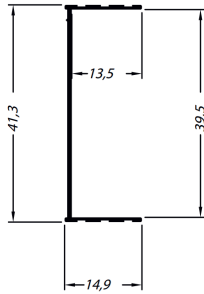

AP90

TRAVESSA

0,220 Kg/m

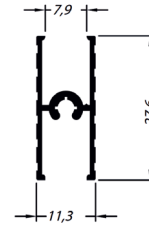

AP87

MONTANTE

0,182 Kg/m

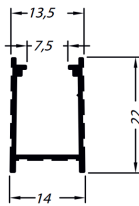

AP106

CADEIRINHA

0,190 Kg/m

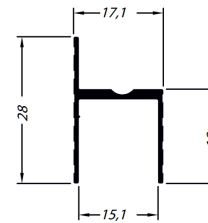

AP35

PRESILHA DA COLUNA

0,327 Kg/m

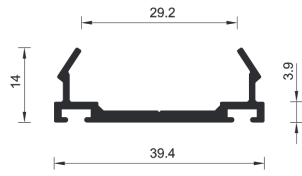

AP34

TAMPA DA PRESILHA

0,242 Kg/m

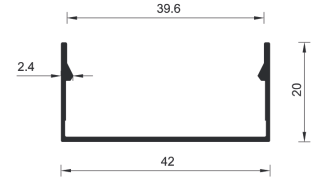

AP36

COLUNA

1,012 Kg/m

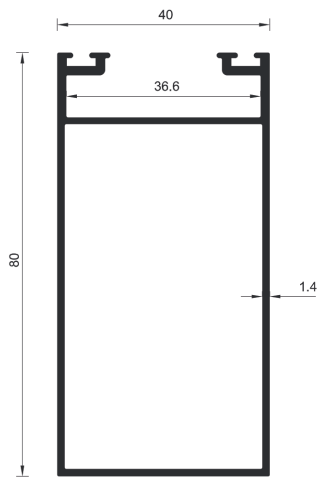

FC543

PRESILHA DA COLUNA

0,415 Kg/m

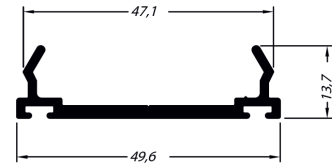

FC542

TAMPA DA PRESILHA

0,329 Kg/m

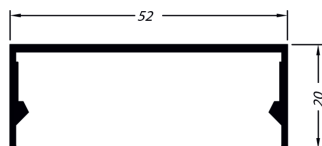

FC017

COLUNA

1,845 Kg/m

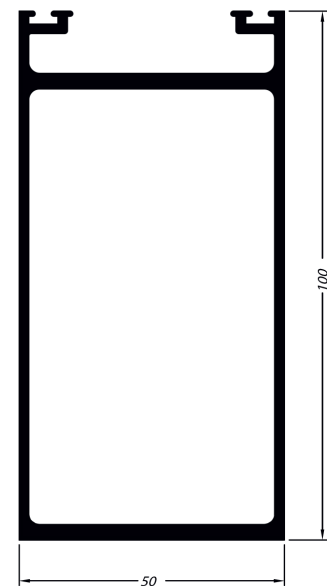



Ideia
Glass

BOX FLEX

Pequeno sim, apertado jamais



BOX Elegance



BOX Due



VISION

Sua nova visão em portas



BOX Encanto



GUI-250

GUIA DESLIZANTE
LINHA MEGA 25



NYL-332

GUIA DESLIZANTE
LINHA SUPRA



NYL-396

GUIA DESLIZANTE
LINHA DIOR



GUI-320

GUIA DESLIZANTE
LINHA MEGA 32

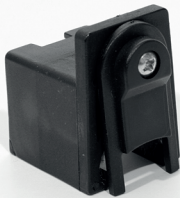

NYL-329

CAIXA DRENO
SUPRA/MEGA 25



NYL-395

CAIXA DRENO
DIOR / MEGA 32



NYL-335

VEDAÇÃO SUPERIOR
SUPRA / MEGA 25



CON-381

VEDAÇÃO SUPERIOR
DIOR / MEGA 32



NYL-035

CALÇO FOLHA FIXA
SUPRA/MEGA 25

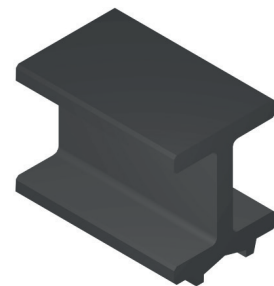

CAL-929

CALÇO VEDANTE DIOR



SUP-622

TRAVA FOLHA
FIXA DIOR

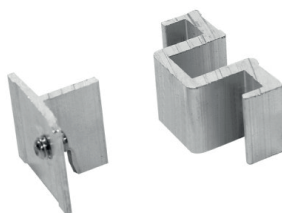

NYL-414

BATENTE SUPRA/
MEGA 25

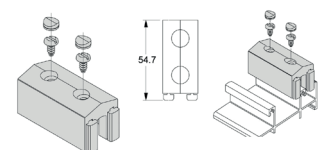

NYL-398

BATENTE DIOR/
MEGA 32

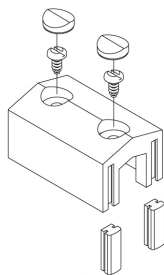

CON-376

FIXADOR TRAVESSA
MAXI AR

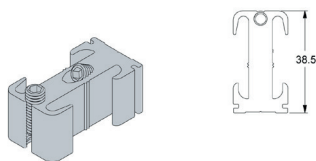

CON-42173

CONEXÃO MONTANTE
LINHA 42



NYL-190

BOTÃO FIXADOR
DO ARREIMATE



ROL-296

ROLDANA DUPLA
AP37 / DS152 PCT 02



ROL-295

ROLDANA QUADRUPLA
AP37/DS152 PCT 02



ROL-301

ROLDANA DUPLA
CONCAVA PCT 02



ROL-302

ROLDANA QUADRUPLA
CONCAVA PCT 02



ROL-1150

ROLDANA
QUADRUPLA AP68/67



ROL-440

ROLDANA REG
E ROLAMENTO
SUPRA / MEGA 25

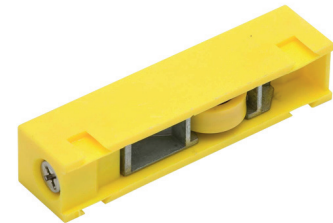

ROL-441

ROLDANA REG
S/ ROLAMENTO
SUPRA / MEGA 25



ROL-439

ROLDANA DUPLA
REG E ROLAMENTO
SUPRA/MEGA 25



ROL-83

ROLDANA UDIPLUS 100
KG SUPRA/MEGA 25



ROL-468

ROLDANA REG
E ROLAMENTO
DIOR / MEGA 32



ROL-413

ROLDANA DUPLA
REG E ROLAMENTO
DIOR/MEGA 32



ROL-82

ROLDANA UDIPLUS 200
KG DIOR/MEGA 32

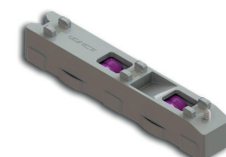

ROL-80

ROLDANA STRONG
SIMPLES 130 KG

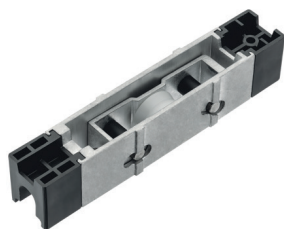

ROL-81

ROLDANA STRONG
DUPLA 260 KG



ROL-239

ROLDANA EM U
PARA PORTÃO

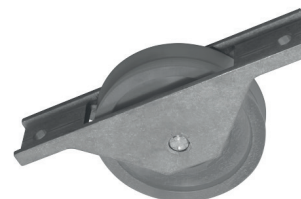

ROL-327

ROLDANA EM V
PARA PORTÃO



ROL-150S

ROLDANA CONCAVA
LINHA SUPRA



ROL-150G

ROLDANA CONCAVA
LINHA DIOR



 **Roto FERMAX**

Tecnologia para Portas e Janelas

FEC-636

FECHO CONCHA
SEM CHAVE 160mm



FEC-637

FECHO CONCHA
AUTOMÁTICO 160mm



FEC-645

FECHO CONCHA
COM CHAVE 160mm



CON-280

CONCHA CEGA
160mm



CON-270

CONTRA FECHO
LATERAL



FEC-055

CONTRA FECHO
CENTRAL



FEC-250

FECHO CONCHA
AUTOMÁTICO SEM
CHAVE 160mm



CON-150

CONCHA CEGA



CON-250

CONTRA FECHO
LATERAL

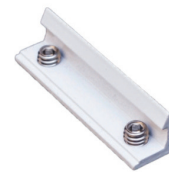

FEC-019

FECHO DE EMBUTIR



FEC-270

FECHO DE EMBUTIR
COM HASTE



FEC-300

FECHO LIVRE/
OCUPADO

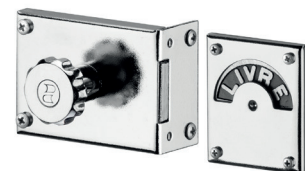

FEC-301

FECHO LIVRE/
OCUPADO



CR-01

CREMONA 2 PONTOS
COM CHAVE
1600mm (INT - EXT)



CR-02

CREMONA 2 PONTOS
COM CHAVE
800mm (INT)



CR-03

MAÇANETA CREMONA



CR-04

CILINDRO PARA PORTA



CR-05

KIT ROSETA



CR-06

KIT CONTRA FECHO



CR-07

HASTE 55mm (EXT)



CR-08

KIT HASTE 90mm
(INT - EXT)



CR-09

CILINDRO PARA
JANELA



STAM 401

FECHADURA PORTA DE GIRO LINHA 25 (25016)



STAM 601

FECHADURA PORTA DE GIRO



STAM 603

FECHADURA PORTÃO



STAM 902

FECHADURA PORTA DE CORRER



STAM 1003

FECHADURA AUXILIAR TETRA



STAM 1005

FECHADURA ROLETE LINHA 30/DIOR/42



STAM 1007

KIT FECHADURA ROLETE + 2 AUXILIAR LINHA 30/DIOR/42



PADO 661

FECHADURA PORTA DE GIRO MAGNUM TODAS AS LINHAS



PADO 931

FECHADURA PORTA DE GIRO ROSETA MONTANTE 100MM



CON-295

CONTRA TESTA LINHA 25/SUPRA



CON-298

CONTRA TESTA LINHA 30/ME



CON-386

CONTRA TESTA LINHA DIOR



CON-409

CONTRA FECHADURA
LATERAL SUPRA



CON-410

CONTRA FECHADURA
CENTRAL SUPRA



CON-310

CONTRA
FECHADURA ME



CON-383

CONTRA FECHO/
FECHADURA
LATERAL DIOR

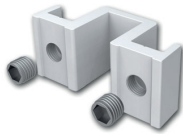

CON-384

CONTRA FECHO/
FECHADURA
CENTRAL DIOR



stam

NYL-042

TAPA FURO 3/8"



NYL-347

CANTO PARA
ARREIMATE MP347



NYL-355

TAMPA MONTANTE
MAXIM-AR SUPRA



NYL-357

TAMPA MONTANTE
SU-049/SU-047



NYL-364

TAMPA MONTANTE
SU-061



NYL-399

TAMPA MONTANTE
ALG-052/ALG-054



NYL-400

TAMPA MONTANTE
ALG-021/ALG-023



TPA-255

TAMPA MONTANTE
MG-25504/MG-25505

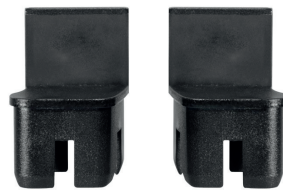

TPA-320

TAMPA MONTANTE
ALG-093A



TPA-321

TAMPA MONTANTE
ALG-093/ALG-094



TPA-173

TAMPA PARA ALG173



TPA-174

TAMPA PARA ALG174





CÓDIGO	TAMANHO	LINHA	PESO MÁXIMO
BRA-705	250mm	SUPRA	7,4Kg
BRA-704	400mm	SUPRA	8,6Kg
BRA-702	500mm	SUPRA	10,8Kg
BRA-703	750mm	SUPRA	13Kg
BRA-725	810mm	SUPRA	16Kg



CÓDIGO	TAMANHO	LINHA	PESO MÁXIMO
BRA-766	345mm	DIOR	22Kg
BRA-767	600mm	DIOR	30Kg
BRA-768	951mm	DIOR	36Kg

FEC-009

FECHO MAXIM AR
C/ BAGUETE SUPRA



FEC-010

FECHO MAXIM AR
S/ BAGUETE SUPRA



FEC-495

FECHO MAXIM AR
DIOR DIREITO



FEC-496

FECHO MAXIM AR
DIOR ESQUERDO



PIV-752

PIVO BASCULANTE
LINHA SUPRA



ALA-057

ALAVANCA
BASCULANTE
LINHA SUPRA



PIV-753

PIVÔ PARA
BASCULANTE



FEC-059

HASTE DE COMANDO



BLI-1200

LIMITADOR
DE ABERTURA
PERFILE/MEGA

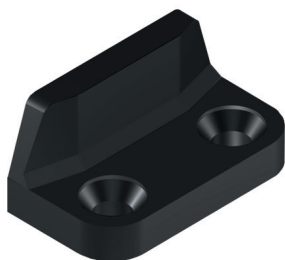

NYL-369

ACABAMENTO
TERMINAL E LIMITADOR
DE ABERTURA



BLI-2300

MOLA DE FIXAÇÃO
DA ESTEIRA



NYL-370

GUIA DA PERSIANA



NYL-375

TAMPA LATERAL
DA PALHETA



TPA-250

TAMPA LATERAL
MG-25515 PAR



TPA-450

TAMPA LATERAL
MG-32110 PAR



TPA-232

TAMPA LATERAL
APF-006 PAR



TPA-231

TAMPA LATERAL
APF-016 PAR



NYL-382

TAMPA LATERAL
MN-031 PAR



NYL-383

TAMPA LATERAL
MN-032 PAR



GUI-035

GUIA CENTRAL DA
PERSIANA MEGA 25



REC-001

RECOLHEDOR
JANELA TUBO 40MM



REC-002

RECOLHEDOR PORTA
TUBO 40MM



REC-003

RECOLHEDOR JANELA
COM ADAPTADOR
PARA TUBO 60MM



REC-004

RECOLHEDOR PORTA
COM ADAPTADOR
PARA TUBO 60MM



PCR-003

PASSA CINTA
LINHA PERFILE



PCR-004

PASSA CINTA
LINHA MEGA



TER-050

TERMINAL DA
PERSIANA



TOPN-018

LIMITADOR TRAVA
DE ABERTURA
DA PERSIANA



VZP-001

PASSO 43mm

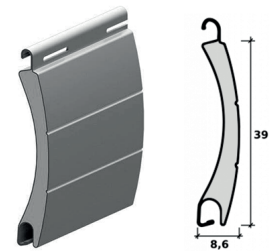

EXPALUM[®]

PERSIANAS E COMPONENTES DE ALUMÍNIO



PARA MOTORES REC 540, REC 541, REC 542 E REC 543

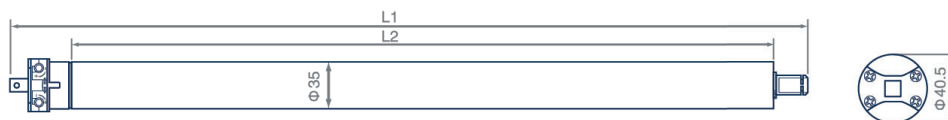

PARA MOTORES REC 550, REC 551, REC 552 E REC 553

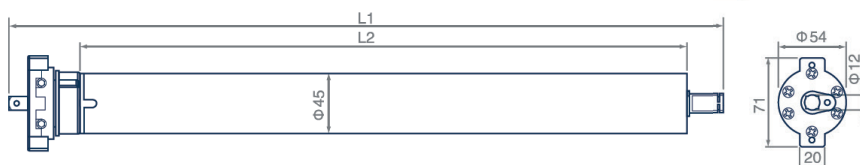

CÓDIGO	TUBO	ACIONAMENTO	PESO levantado (kg)	TENSÃO(V) /FREQ.(Hz)	VELOCIDADE (rpm)	POTÊNCIA ABSORVIDA (W)	CONSUMO CORRENTE (A)	COMPRIMENTO TOTAL (mm)
REC540	40	interruptor	23	120/60	18	160	1,32	523
REC541	40	controle 1 canal	23	120/60	18	160	1,32	643
REC542	40	interruptor	23	230/60	17	126	0,56	523
REC543	40	controle 1 canal	23	230/60	17	126	0,56	643
REC550	60	interruptor	52	120/60	19	170	1,5	474
REC551	60	interruptor	52	230/60	15	156	0,68	474
REC552	60	controle 1 canal	52	120/60	19	170	1,5	574
REC553	60	controle 1 canal	52	230/60	15	156	0,68	574





CÓDIGO	ABAS	LINHA
DOB-692	2	LINHA 25
DOB-689	2	LINHA SUPRA
DOB-751	2	LINHA 30
DOB-704	2	LINHA 42



CÓDIGO	ABAS	LINHA
DOB-840	3	LINHA SUPRA
DOB-780	3	LINHA 30
DOB-828	3	LINHA DIOR
DOB-700	3	LINHA 42
DOB-753	3	LINHA D' CASA

NYL-362

GUIA DESLISANTE
 LINHA CAMARÃO



NYL-336

GUIA JANELA
 CAMARÃO



DOB-837

DOBRADIÇA TRIPLA
 JANELA CAMARÃO



DOB-838

DOBRADIÇA TRIPLA
 COM PUXADOR
 JANELA CAMARÃO



FEC-695

FECHO JANELA
 CAMARÃO COM
 PUXADOR



HAS-812

HASTE CAMARÃO
 750MM

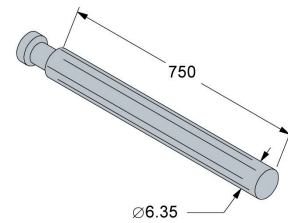

HAS-813

HASTE CAMARÃO
 1200MM

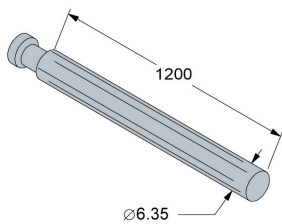

SUP-624

SUPORE GUIA DA
 FOLHA CAMARÃO



PUX-143

PUXADOR
 FERMAX 20cm



PUX-142

PUXADOR
 FERMAX 16cm



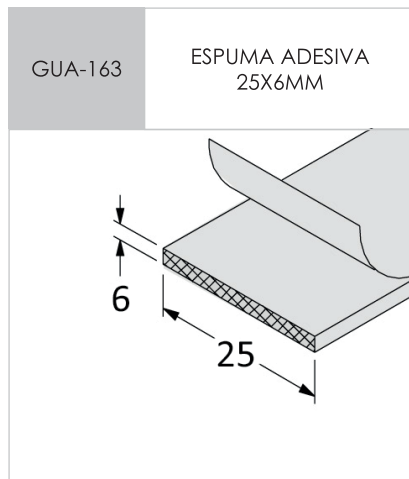
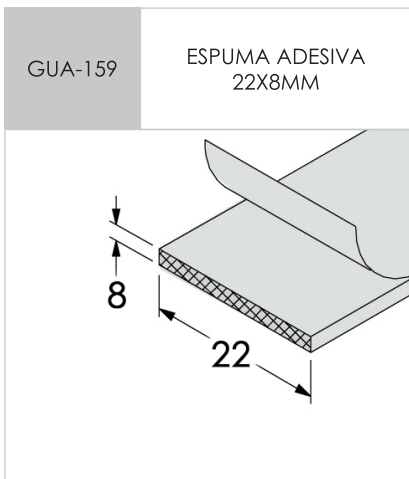
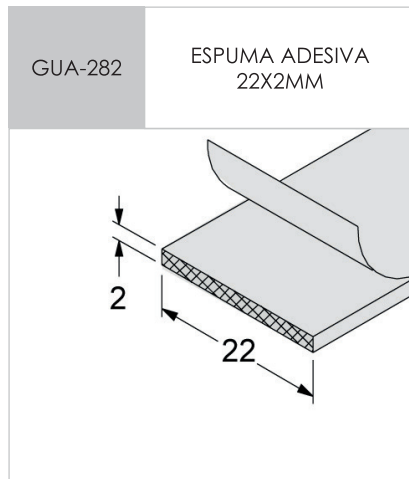
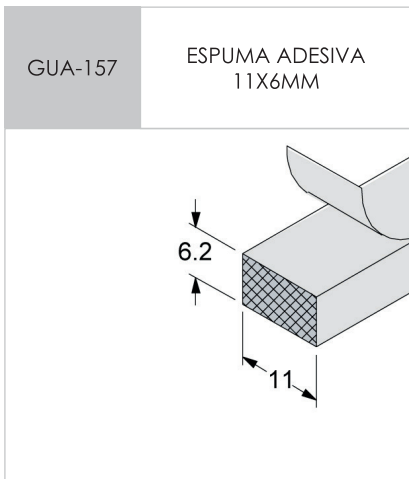
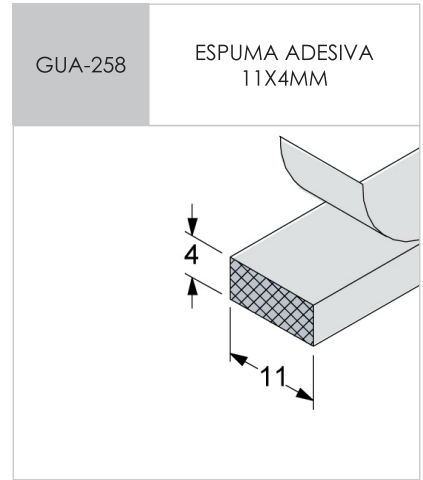
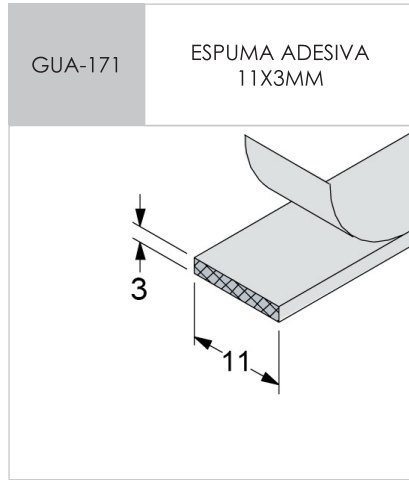
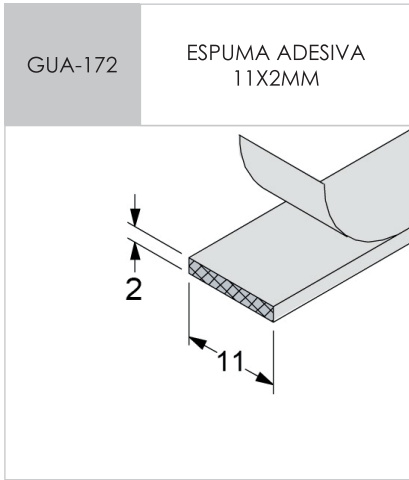

GUA-051

GUARNIÇÃO
CUNHA 8MM



GUA-051A

GUARNIÇÃO
CUNHA 8,5MM

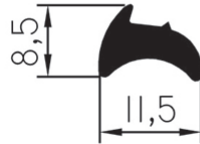

GUA-052

GUARNIÇÃO
CUNHA 9MM

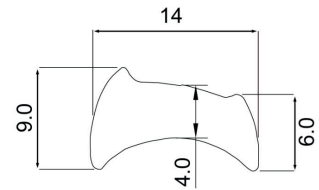

GUA-008

GUARNIÇÃO
FACHADA CORTINA
/ POLICARBONATO

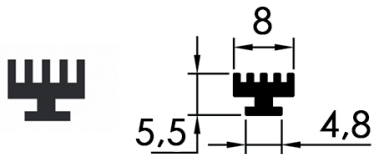

GUA-030

GUARNIÇÃO
FACHADA CORTINA

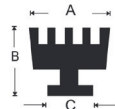

A:12,00mm
B:6,30mm
C:5,00mm
EPDM

FIT-DF PVII

FITA DUPLA FACE
FACHADA PVII
E ATLANTA



FIT-DF ACM

FITA DUPLA FACE ACM



FIT-AL

FITA ALUMINIO PARA
POLICARBONATO



FIT-P S

FITA POROSA PARA
POLICARBONATO



GUA-256

GUARNIÇÃO CUNHA

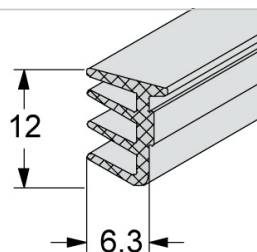

GUA-259

GUARNIÇÃO CUNHA

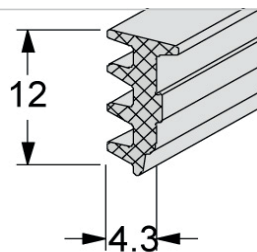

GUA-033

GUARNIÇÃO
SACADA 08mm

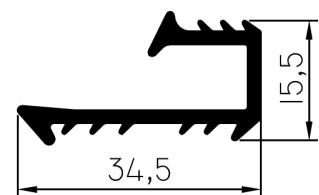

CHU-817

CHUMBADOR
EXPANSIVO 89MM

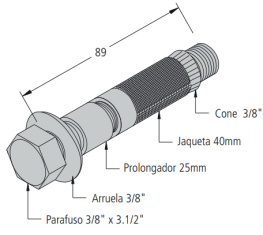

CHU-818

CHUMBADOR
EXPANSIVO 114MM

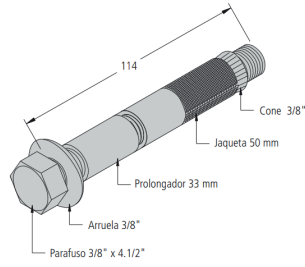

PAR-922

PARAFUSO 25MM
COM PORCA

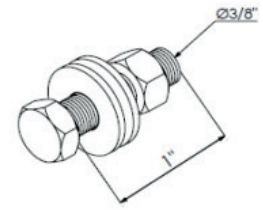

PAR-923

PARAFUSO 102MM
COM PORCA

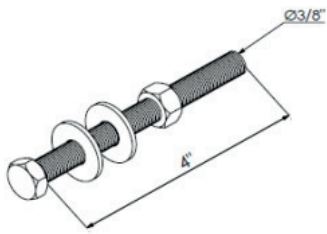

PRE-950

PRESILHA DA
FOLHA FIXA

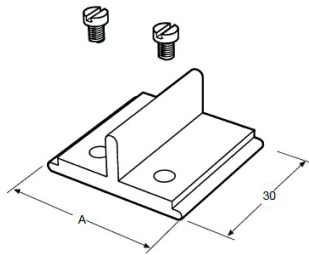

PRE-951

PRESILHA DA COLUNA

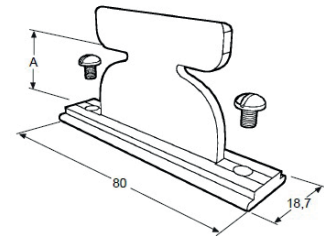

PRE-953

PRESILHA DO
FORRO E RODAPE

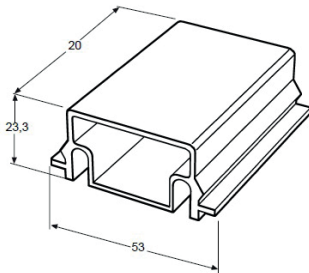

PRE-954

PRESILHA DO
FORRO E RODAPE

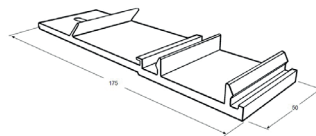

LUV-976

LUVA PARA
COLUNA FC-244

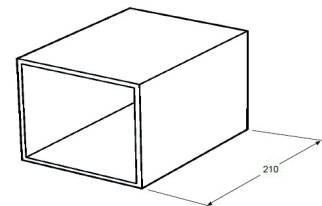

LUV-974

LUVA PARA
COLUNA FC-202

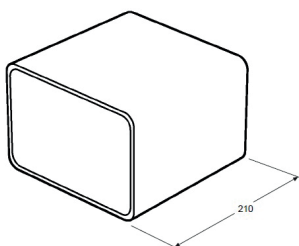

ANC-964

ANCORAGEM
INFERIOR PARA
COLUNA

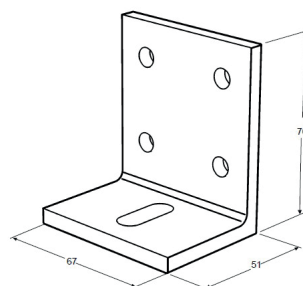

ANC-966

ANCORAGEM PARA
COLUNA DE CANTO

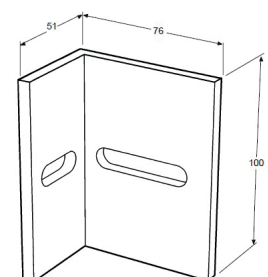

ANC-965

ANCORAGEM
TELESCÓPICA

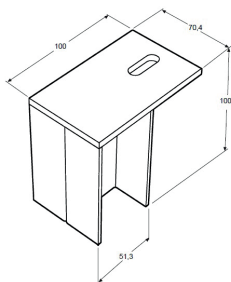

ANC-951

ANCORAGEM
PARA COLUNA
FC-202 / FC-233

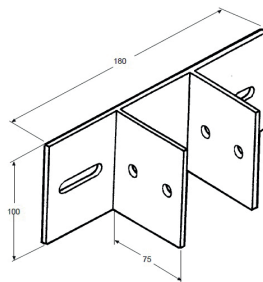

GUA-007

GUARNIÇÃO DA
PINGADEIRA



GUA-160

GUARNIÇÃO
DA COLUNA

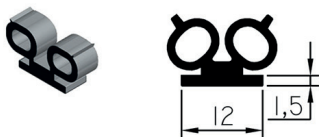

GUA-161

GUARNIÇÃO
PARA VEDAÇÃO
DAS FOLHAS

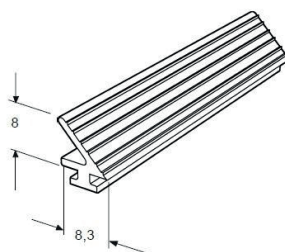

GUA-162

GUARNIÇÃO DA
COLUNA DE CANTO

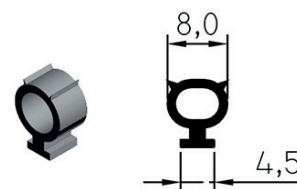

FEC-152

FECHO DE MAXIM AR
DIREITO PELE DE VIDRO



FEC-155

FECHO DE MAXIM AR
PARA ESQUERDO
PELE DE VIDRO



FMA-069

FECHO MAXIM AR
ALAVANCA COM PINO



BRA-588

BRAÇO MAXIM AR
PELE DE VIDRO 342MM



BRA-589

BRAÇO MAXIM AR
PELE DE VIDRO 600MM



BRA-590

BRAÇO MAXIM AR
PELE DE VIDRO 950MM



BRA-591

**BRAÇO MAXIM
AR PELE DE VIDRO
1200MM**



PRE-205

**PRESILHA DE FIXAÇÃO
DOS MÓDULOS**

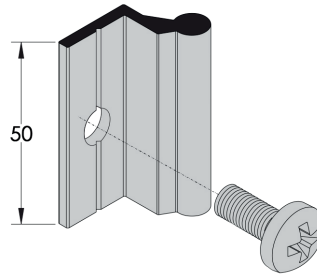

PRE-206

**PRESILHA DE FIXAÇÃO
HORIZONTAL**

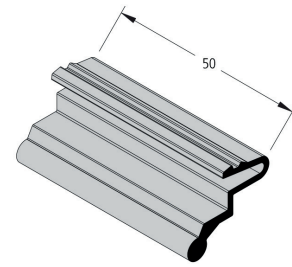

PRE-207

**CALÇO DE APOIO
INFERIOR HORIZONTAL**

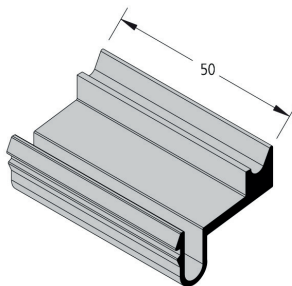

FIX-208

**FIXADOR DA
TRAVESSA AFA-233**

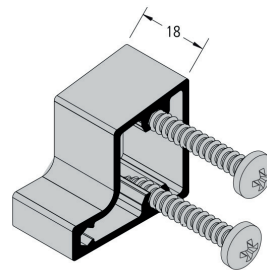

CNX-210

MACHO DE CONEXÃO

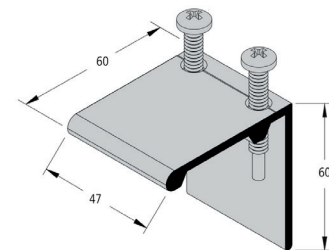

LUV-211

**LUVA DA COLUNA
AFA-200**

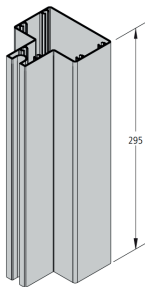

LUV-212

**LUVA DA COLUNA
AFA-235 300MM**

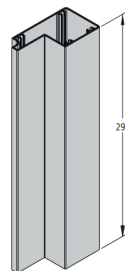

LUV-517

**LUVA TELESCÓPICA
PARA AFA-203**

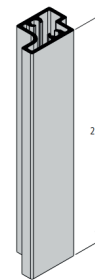

LUV-214

**FIXADOR DA
COLUNA AFA-205**

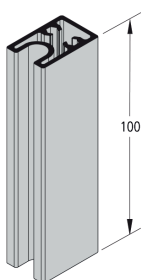

ANC-216

**FIXADOR DA
COLUNA AFA-200**

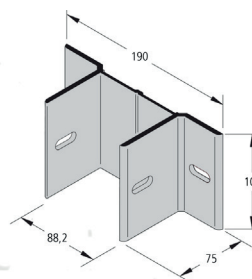

PRE-236

**PRESILHA ARREIMATE
- SOLEIRA**

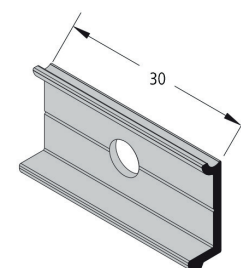

LUV-238

LUVA TELESCÓPICA
PARA COLUNA
AFA-236

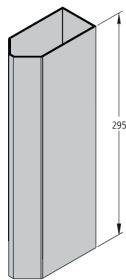

LUV-239

LUVA TELESCÓPICA
PARA COLUNA
AFA-236

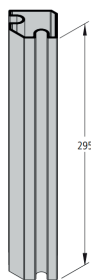

LUV-240

LUVA TELESCÓPICA
PARA COLUNA
AFA-242

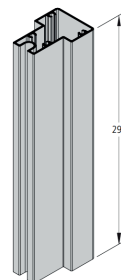

ANC-242

ANCORAGEM PARA
COLUNA 90° EXTERNA

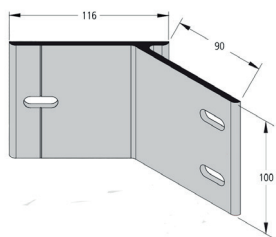

LUV-244

LUVA TELESCÓPICA
PARA COLUNA
AFA-202

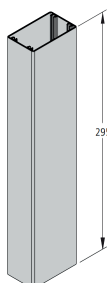

FIX-253

FIXADOR VERTICAL
PARA COLUNA
AFA-205

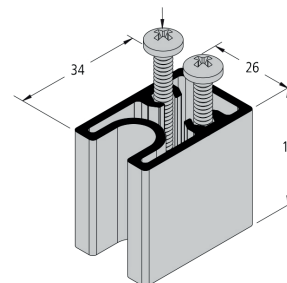

PAR-226

PRISIONEIRO 127MM

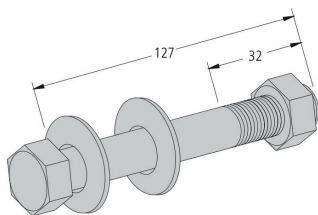

GUA-250

GUARNIÇÃO EXTERNA

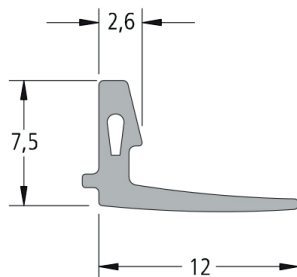

GUA-202

GUARNIÇÃO DA
COLUNA E TRAVESSA

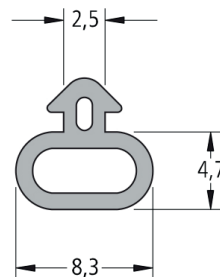

GUA-218

GUARNIÇÃO
DA PINGADEIRA
DA FOLHA

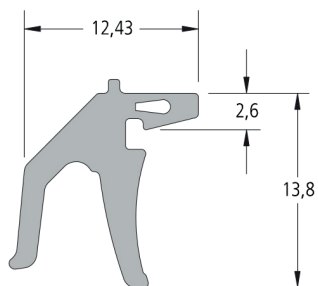

FIT-DF PVII

FITA DUPLA FACE
FACHADA PVII
E ATLANTA



SIKA EST PT

SILICONE ESTRUTURAL
SIKA PRETO



AL-004

ALICATE DE
APLICAÇÃO PARA
PELE DE VIDRO



RL-004

ROLETE DE APLICAÇÃO
PARA PELE DE VIDRO



ANC-967

ANCORAGEM
COLUNA 90°

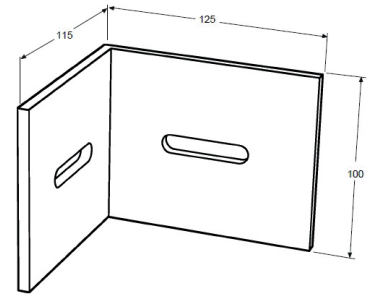

DAU
BRASIL

1002A

**BOTÃO CORREÇÃO
 COM LÂMINA**

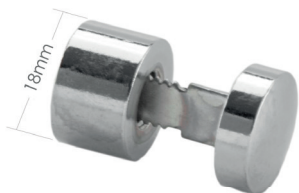

1002B

**BOTÃO CORREÇÃO
 COM LÂMINA
 E ENGATE**



1003C

**CORRENTE PARA
 BASCULANTE**



1003A

**ARGOLA PARA
 BASCULANTE**



1005

**ENGATE PARA
 CORRENTE EM
 ALVENARIA**



1101A

DOBRADIÇA SUPERIOR

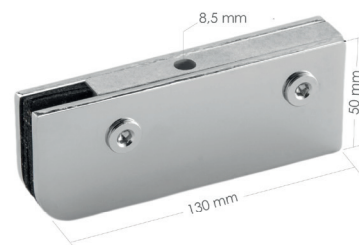

1201A

**PIVÔ PARA
 DOBRADIÇA SUPERIOR**

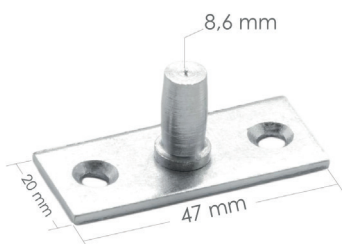

1102

DOBRADIÇA INFERIOR



1013A

**PIVÔ PARA
 DOBRADIÇA INFERIOR**

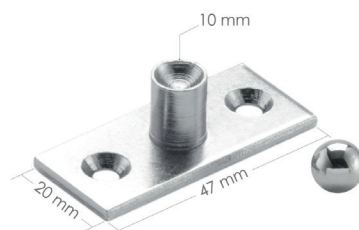

1101G

**DOBRADIÇA
 SUPERIOR GRANDE**



1201G

**PIVÔ PARA
 DOBRADIÇA
 SUPERIOR GRANDE**

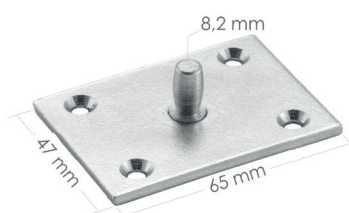

1102G

**DOBRADIÇA
 INFERIOR GRANDE**



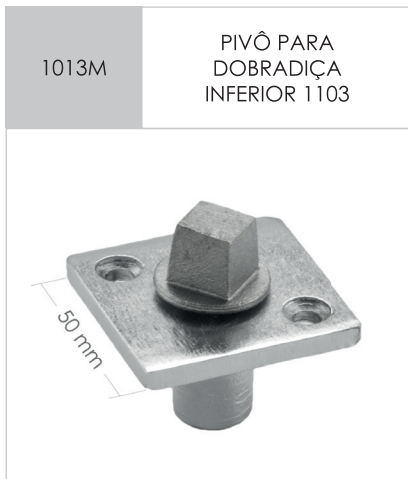
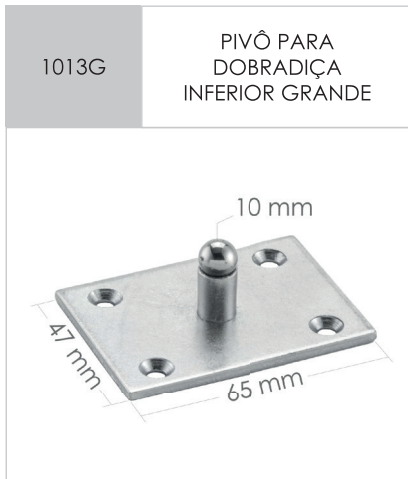

1129D

DOBRADIÇA
 AUTOMÁTICA
 DIREITA DUPLA



1129E

DOBRADIÇA
 AUTOMÁTICA
 ESQUERDA DUPLA



1136

DOBRADIÇA SIMPLES
 PARA JANELA



1137

DOBRADIÇA DUPLA
 PARA JANELA



1921

DOBRADIÇA MAXIM-
 AR V/A 40mm



1922

DOBRADIÇA MAXIM-
 AR V/V 40mm

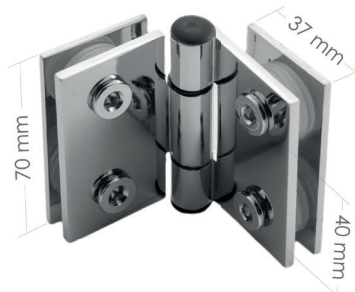

1133

DOBRADIÇA MAXIM-
 AR V/A 50mm



1134

DOBRADIÇA MAXIM-
 AR V/V 50mm



1587A

CONJUNTO DE
 ACESSÓRIOS
 MAXIM-AR V/A

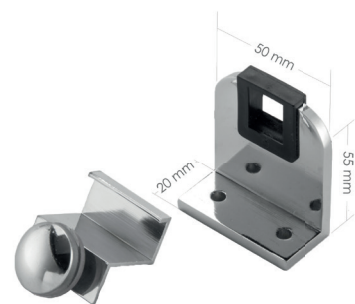

1587V

CONJUNTO DE
 ACESSÓRIOS
 MAXIM-AR V/V

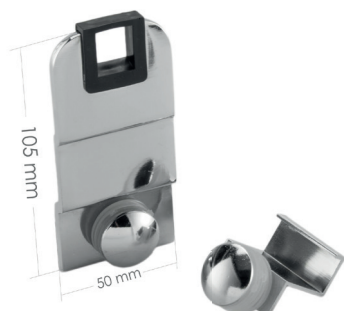

1589A

CONJUNTO DE
 ACESSÓRIOS MAXIM-
 AR 01 FURO V/A

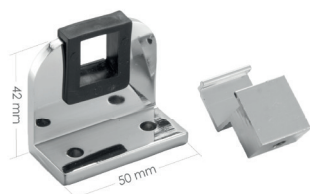

1923

HASTE PARA MAXIM-
 AR 1587 - 20, 30,
 40, 50 E 60cm



1125

ROLDANA SIMPLES
08 E 10mm



1125X

ROLDANA EXCÊNTRICA
08 E 10mm



1125-FER

ROLDANA EXCÊNTRICA
FERMAX



1125D

ROLDANA DUPLA



1122M

MINI CARRINHO
SIMPLES



1122

CARRINHO DUPLO
ATÉ 80 Kg

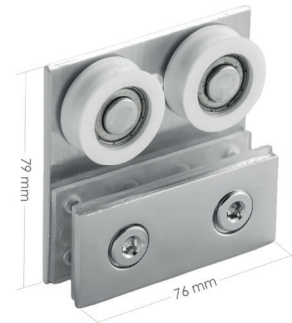

1126AC

CARRINHO DUPLO



ROL-VK

ROLDANA PARA
KIT VERSATIK



BROCK 08

ROLDANA BROCK
PARA 08mm



BROCK 10

ROLDANA BROCK
PARA 10mm



BROCK
DUPLA

ROLDANA
BROCK DUPLA



1130

DOBRADIÇA PINO
100mm PARA
BASCULANTE



1231

DOBRADIÇA BUCHA
 100mm PARA
 BASCULANTE



1123

DOBRADIÇA PINO
 PARA BASCULANTE



1230

DOBRADIÇA BUCHA
 PARA BASCULANTE



1801

BATEDEIRA PARA
 TRINCO DE
 BASCULANTE

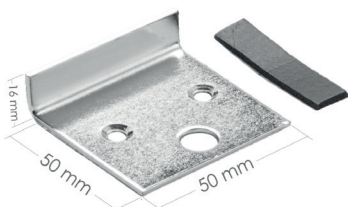

1523

TRINCO CENTRAL
 PARA BASCULANTE



1203

SUPOORTE DE BANDEIRA
 PARA DOBRADIÇA



1209

FACÃO SIMPLES PARA
 BANDEIRA E FIXO



1302

SUPOORTE DE CANTO



1305

SUPOORTE CENTRAL
 SEM NÚCLEO



1306

SUPOORTE PARA UNIÃO
 DE 02 VIDROS



1307

SUPOORTE PARA UNIÃO
 DE 03 VIDROS



1308

SUPOORTE PARA UNIÃO
 DE 03 VIDROS

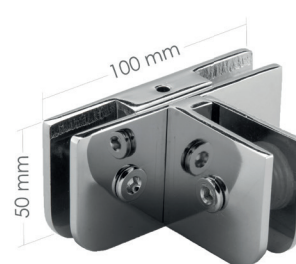

1310

SUPORE SEM
NÚCLEO PARA UNIÃO
DE 03 VIDROS



1316

SUPORE SEM
NÚCLEO PARA UNIÃO
DE 04 VIDROS



1320

SUPORE CENTRAL
PARA UNIÃO DE
02 VIDROS A 90°



1321

SUPORE PISO-TETO
PARA UNIÃO DE
02 VIDROS A 90°



1322

SUPORE DE CENTRO
PARA UNIÃO DE
02 VIDROS A 90°



1326

MINI SUPORE
PARA FIXAÇÃO



1329

SUPORE CENTRAL
50x50mm

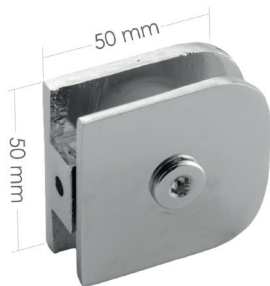

1340

SUPORE DE CANTO
COM ROSCA
PARA ROL-1150



1341

SUPORE COM ROSCA
PARA ROL-1150



3019

GRAPA 50x65
SEN RECORTE



1927

PORTA CADEADO



1520

FECHADURA PARA
PORTA DE GIRO



1504

CONTRA-FECHADURA
 V/V PARA 1520



1531

CONTRA-FECHADURA
 V/V COM BATENTE
 PARA 1520



1504A

BATEDEIRA V/A
 PARA 1520



3530

FECHADURA PARA
 PORTA DE CORRER



3534

CONTRA-FECHADURA
 V/V PARA 3530



3230

BATEDEIRA V/A
 PARA 3530



3210

FECHADURA PARA
 PORTA DE ABRIR
 COM FURAÇÃO



3211

CONTRA-FECHADURA
 V/V PARA 3210



3532

FECHADURA DIREITA
 PARA JANELA



3536

CONTRA-FECHADURA
 V/V PARA 3536



1510M

MINI FECHADURA
 PARA JANELA

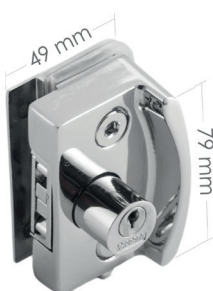

1511M

CONTRA-FECHADURA
 V/V PARA 1510M

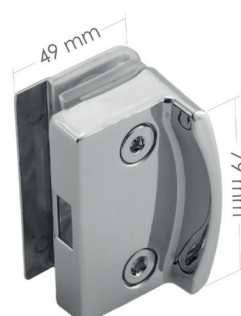

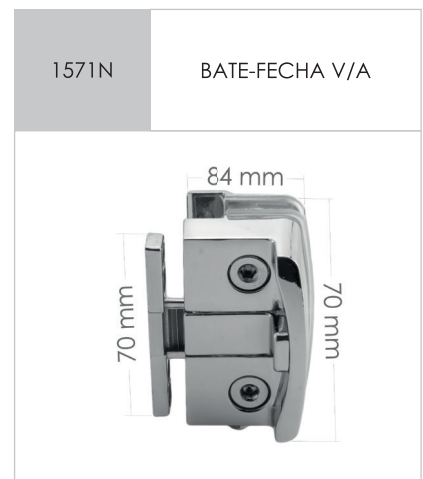
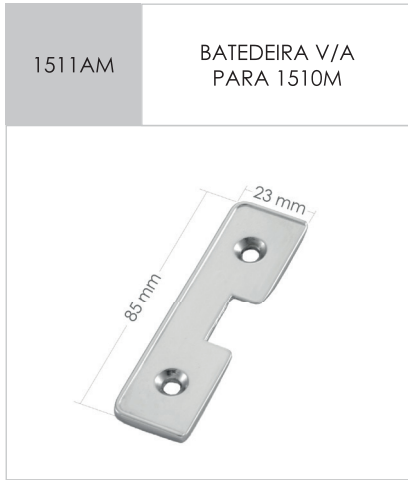

1702

FIXADOR DE PORTA



1710M

MINI CONJUNTO
MÃO DE AMIGO



1711

CONJUNTO MÃO
DE AMIGO



1800

TRINCO PARA
JANELA DE CORRER



1800A

TRINCO DE PRESSÃO
PARA JANELA
DE CORRER



1800B

TRINCO PARA
JANELA DE CORRER



1800C

TRINCO DE PRESSÃO
PARA JANELA
DE CORRER

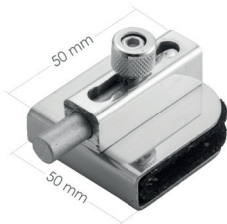

1810D

TRINCO DIREITO PARA
JANELA DE CORRER



1810E

TRINCO ESQUERDO
PARA JANELA
DE CORRER



1813









TRINCO CENTRAL
PARA JANELA E
PORTA DE CORRER



1913P

FECHADURA DE
PRESSÃO PARA RACK



<p>PUXADOR H TUBULAR</p>	<p>30, 60 E 80mm ENTRE FUROS</p>	<p>PUXADOR H BARRA CHATA</p>	<p>30, 60 E 80mm ENTRE FUROS</p>	<p>PUXADOR EM S TUBULAR</p>	<p>FECHADURA PORTA DE GIRO 190mm</p>
					
<p>PUXADOR SPACE</p>	<p>PUXADOR DE 01 FURO COM PONTAS ADESIVAS</p>	<p>PUXADOR DE RESINA</p>	<p>INCOLOR E FUMÊ</p>	<p>PUXADOR DE VIDRO</p>	<p>INCOLOR, FUMÊ E VERDE</p>
					
<p>PUXADOR OVAL</p>	<p>30mm ENTRE FUROS</p>	<p>1629C</p>	<p>PUXADOR PARA JANELA</p>	<p>1629B</p>	<p>PUXADOR PARA BOX</p>
					

1406 BATENTE LATERAL



1408 BATEDOR CENTRAL DE JANELA



CUNHA PACOTE COM 100 UNIDADES



SUPORE TUCANO TAMANHOS P, M E G



FENDA 04, 06, 08 E 10mm



BOTÃO FRANCÊS PLÁSTICO E METAL



BOTÃO DUPLO PLÁSTICO E METAL



BOTÃO CHANFRADO TRINCO DIREITO PARA JANELA DE CORRER



MOLA DE PISO DORMA E SOPRANO



MOLA AÉREA SOPRANO



FECHADURA ELETRICA AMELCO V/A E V/V



PROLONGADORES TAMANHOS 25x25, 25x50, 25x100, 40x25, 40x50 e 40x100



APLICADOR

APLICADOR DE SILICONE REFORÇADO



METRO

METRO EM MADEIRA COM 2m



TOYO

CORTADOR TOYO TC-90



VENTOSA

VENTOSA DUPLA



VENTOSA

VENTOSA TRIPLA



TORRE

TORRE EM INOX 30 e 40cm



SILICONE ACÉTICO

INCOLOR, BRONZE, PRETO E BRANCO



SILICONE PU

BRANCO E CINZA



SILICONE NEUTRO

INCOLOR



SILICONE ESTRUTURAL

PRETO



FIXA ESPELHO

ARGACON 400g



VEDA CALHAS

ARGACON 400g



PARAFUSO DE MONTAGEM COM PONTA GUIA

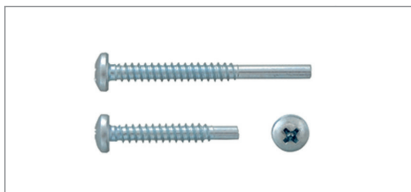

CÓDIGO	TIPO	MEDIDA
PAR-427	PHILIPS CABEÇA PAINEL	4,8 x 32
PAR-430	PHILIPS CABEÇA PAINEL	4,8 x 50

PARAFUSO DE MONTAGEM



CÓDIGO	TIPO	MEDIDA
PAR-302	PHILIPS CABEÇA CHATA	3,9 x 32
PAR-304	PHILIPS CABEÇA PAINEL	4,2 x 19
PAR-306	PHILIPS CABEÇA CHATA	4,2 x 25
PAR-308	PHILIPS CABEÇA CHATA	4,2 x 38
PAR-310	PHILIPS CABEÇA CHATA	4,2 x 50

PARAFUSO DE MONTAGEM COM PONTA BROCA

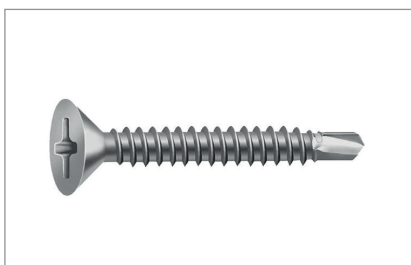

CÓDIGO	TIPO	MEDIDA
PAR-421	PHILIPS CABEÇA CHATA	4,2 x 19
PAR-424	PHILIPS CABEÇA CHATA	4,2 x 25
PAR-422	PHILIPS CABEÇA CHATA	4,2 x 32

PARAFUSO EM AÇO INOX

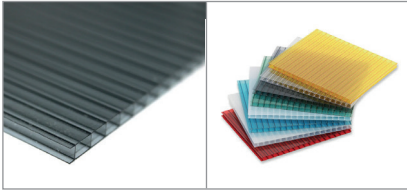

CÓDIGO	TIPO	MEDIDA
PAR-510	PHILIPS PONTA GUIA	4,2 x 32
PAR-520	PHILIPS PONTA GUIA	4,8 x 32
PAR-505	PHILIPS CABEÇA CHATA	4,2 x 25
PAR-508	PHILIPS CABEÇA CHATA	4,2 x 32
PAR-500	PHILIPS ROSCA MECÂNICA	M5 x 12

CHAPAS DE POLICARBONATO

DESCRIÇÃO	CORES
Policarbonato Alveolar 2,10 x 6,00 - 06mm	Fumê, Incolor, Bronze e Refletiva
Policarbonato Alveolar 2,10 x 6,00 - 10mm	Fumê, Incolor Bronze e Refletiva

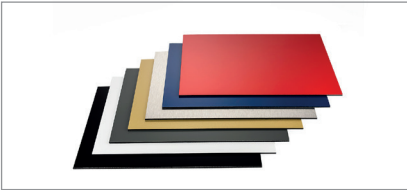
CHAPAS DE ACM

DESCRIÇÃO	CORES
Chapa de ACM 1,22 x 5,00 - 03mm	Branco, Preto, Azul e Cinza
Chapa de ACM 1,50 x 5,00 - 03mm	Branco, Preto, Azul e Cinza

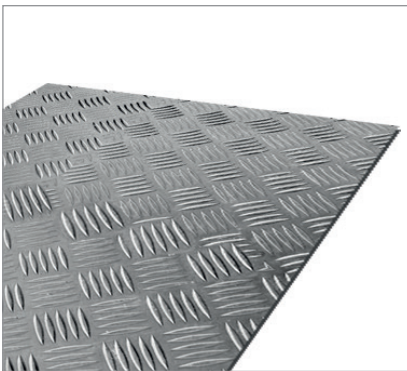
CHAPAS XADREZ

2000 x 1000 x 1,20mm	Natural
2500 x 1000 x 1,20mm	Natural
2500 x 1000 x 1,50mm	Natural
3000 x 1000 x 2,20mm	Natural
3000 x 1250 x 3,70mm	Natural

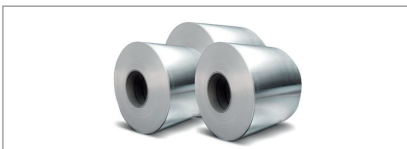
BOBINAS

1000 x 0,50mm	Natural
1000 x 0,70mm	Natural

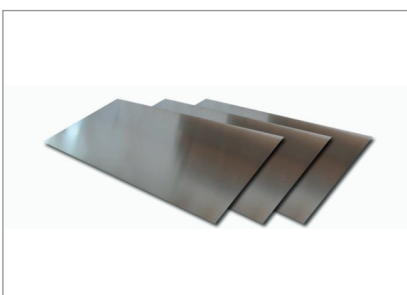
CHAPA LISA

2000 x 1000 x 1,20mm	Natural
2000 x 1000 x 2,00mm	Natural
3000 x 1000 x 1,20mm	Natural
3000 x 1250 x 2,00mm	Natural